

HIWIN®



DATORKER®
Strain wave gear

DATORKER® shaft gear unit

DATORKER® shaft gear unit

DATORKER® shaft gear units are characterised by high precision, high efficiency, high torsional rigidity and low starting torque. They are widely used in robotics, automation, semiconductor technology, machine tools and many other sectors of industry.

Contents

1	General information.....	6
1.1	Characteristics DATORKER® strain wave gears	6
2	Selection principle.....	9
2.1	Process for selecting a DATORKER® shaft gear unit	9
2.2	Confirmation of application condition	10
2.3	Calculation of the load torque, the speed and the service life	11
2.4	Selection of DATORKER® shaft gear unit design and specification	12
2.5	Calculation of the service life of the crossed roller bearing	13
2.6	Calculation of efficiency	13
2.7	Order code DATORKER® strain wave gears	14
2.8	Type/Function	14
2.9	Technical data	15
3	DSC-PO with motor.....	16
3.1	Technical data	16
3.2	Dimensions	17
4	DSC-PO.....	18
4.1	DSC-PO design	19
5	DSC-CO.....	22
5.1	DSC-CO design	23
6	DSH-PH.....	26
6.1	DSH-PH design	27
7	DSH-AH.....	29
7.1	DSH-AH design	30

DATORKER® strain wave gears

General information

1. General information

1.1 Characteristics DATORKER® strain wave gears

DATORKER® strain wave gears has the characteristics of high precision, high efficiency, high torsional rigidity and low starting torque. It is widely used in robots, automation equipment, semiconductor equipment, machine tools and other industries.

Features DATORKER® strain wave gears

- Compact and light weight – Easy for user to assemble and work with
- High accuracy – Provides stable repeatability and positioning
- Improved lubricating properties
- High torque – Widely use in automation and inspection equipment
- Wide reduction ratio – Various choices available under same model

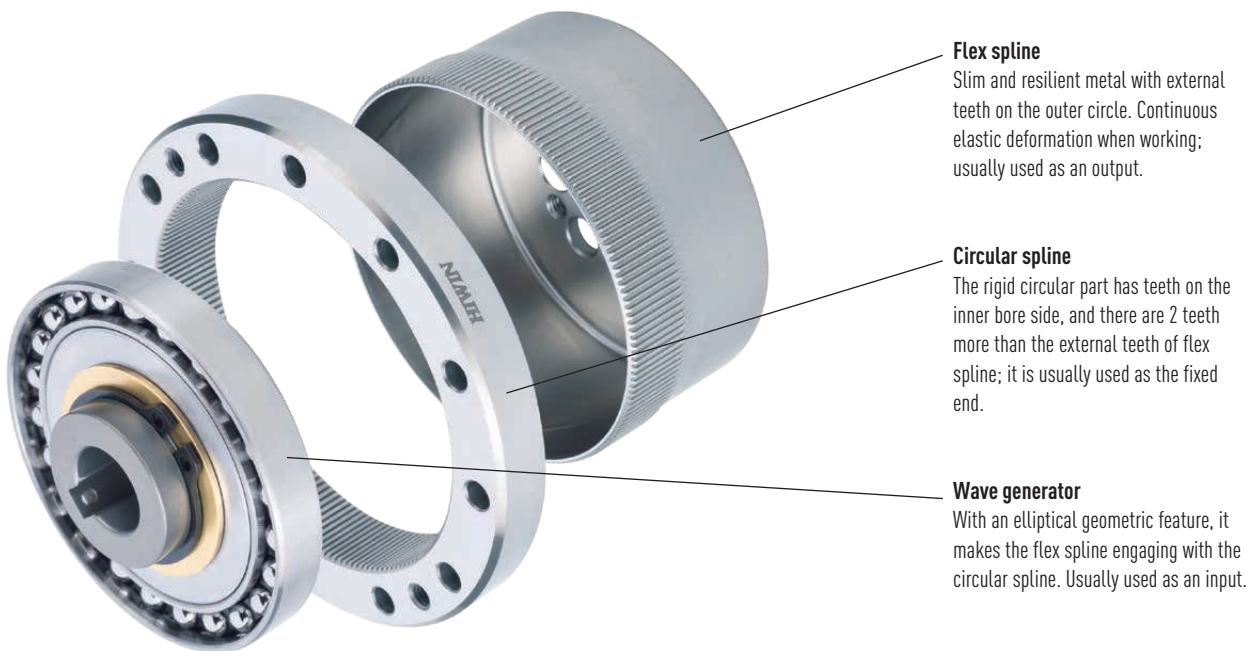

1.1.1 Backlash-free

In a mechanical system, maximum backlash describes the maximum displacement or rotation in a given direction while a part is held stationary. The backlash of the HIWIN DATORKER® shaft gear unit is damped to "0" due to the mechanical construction.

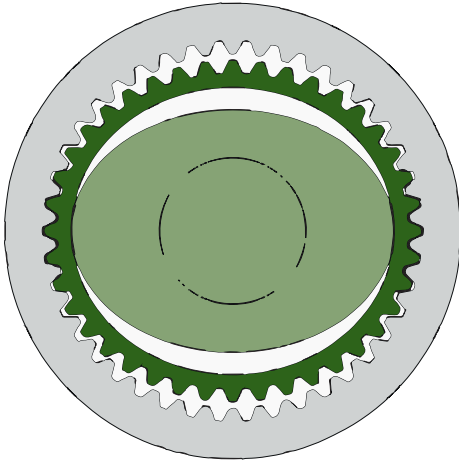

Fig. 1.1 Mechanical engagement of the teeth of a DATORKER® shaft gear unit

1.1.2 Positioning accuracy

The positioning accuracy depends on several factors. On the one hand, the accuracy of the angular transmission plays a role; this indicates the basic accuracy of the gear unit. In addition, there is angular displacement due to the torsional rigidity; this depends on the applied torque and the resulting angular displacement is subject to a hysteresis loss.

1.1.2.1 Accuracy of angular transmission

With an input angle of rotation (θ_1), a theoretical output angle of rotation (θ_2) results based on the reduction ratio. The difference between the theoretical output rotation angle (θ_2) and the actual output rotation angle (θ_3) indicates the accuracy of the angular transmission (θ_f).

$$\theta_2 = \frac{\theta_1}{\text{Reduction ratio}}$$

$$\theta_f = \theta_3 - \theta_2$$

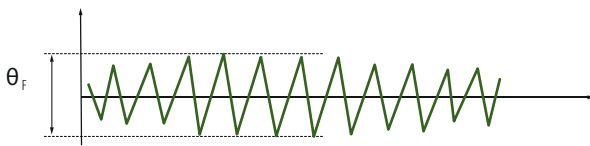

DATORKER® strain wave gears

General information

1.1.2.2 Torsional rigidity

The torsional rigidity indicates the factor of the change in angle of the gear unit output side as a function of the torque when the input side is stationary. The slope of the "torque torsion angle diagram" is expressed as a spring constant. The "torque torsion angle diagram" is divided into three parts and the spring constant of each section represents K_1 , K_2 and K_3 .

- K_1 refers to the spring constant from "0" to " T_1 "
- K_2 refers to the spring constant from " T_1 " to " T_2 "
- K_3 refers to the spring constant with a torque over " T_2 "

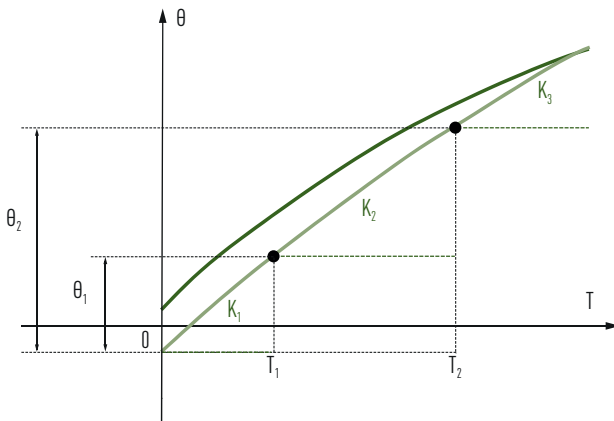

Fig. 1.2 Torque torsion angle diagram

1.1.2.3 Hysteresis loss

After the torque is applied at the nominal value and reset to "0", the torsion angle is not completely "0" and has some displacement (B-B'), which is called hysteresis loss. The hysteresis loss is mainly caused by internal friction. When the torque is extremely small, it is almost non-existent.

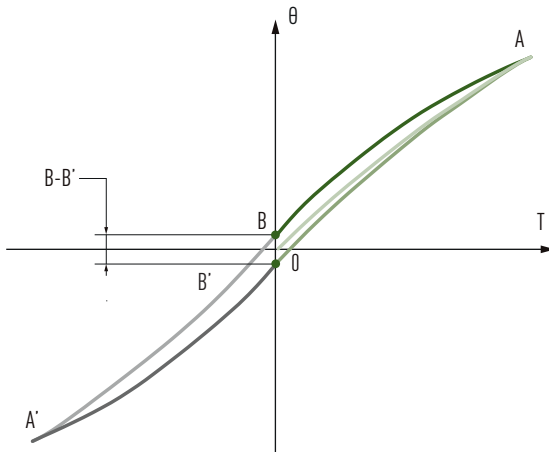

Fig. 1.3 Hysteresis loss B-B'

1.1.3 Low starting torque

The starting torque defines the torque required without load to set the gear unit in motion. Because the shaft generator is supported by balls, only the rolling friction has to be overcome, resulting in very low starting torques.

1.1.3.1 Starting torque

The starting torque defines the torque when the shaft generator is used as the drive side of the gear unit. It consists mainly of the rolling friction of the shaft generator and the radial bearings as well as the shaft sealing rings in the sealed series.

1.1.3.2 Reverse starting torque

The reverse starting torque defines the torque required when the shaft generator is used as the driven side. This is higher because the rotary movement is initiated via the tooth flanks, which creates additional sliding friction.

1.1.4 High tilting moments thanks to integrated crossed roller bearing

HIWIN crossed roller bearings consist of an inner ring, an outer ring, cylindrical rollers arranged at a 90° angle and spacers in between. Due to the cross arrangement of the cylindrical rollers, axial forces from both directions, radial forces, tilting moment loads and any load combinations can be absorbed with just one bearing. Thanks to the direct integration of the bearings into the gear units, DATORKER® shaft gear units are very compact.

2. Selection principle

2.1 Process for selecting a DATORKER® shaft gear unit

Definition of application condition

- Each movement should be specified as precisely as possible in the cycle description



Calculation of the load torque, the output speed and the service life

- Calculate the load torques, the output speed and the service life using the movements given in the cycle description.



Selection of design and specifications of the DATORKER® shaft gear unit

- Select the version based on the motor connection and the ambient conditions
- The specifications can be selected on the basis of the calculated load torques and speeds



Calculation of the service life of the HIWIN crossed roller bearing

- Calculate the necessary service life taking into account all axial forces, radial forces and tilting moment loads.



Selection finished



DATORKER® strain wave gears

Selection principle

2.2 Confirmation of application condition

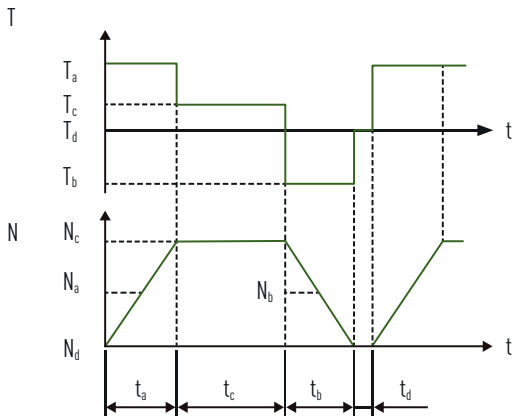

Table 2.1 Confirmation of application condition

	Load torque	Time	Output speed	Maximum output speed	Maximum input speed
Start time (acceleration)	T_a	t_a	N_a	N_{max}	n_{max}
Operating time (constant)	T_c	t_c	N_c		
Stop time (deceleration)	T_b	t_b	N_b		
Switch-off time	T_d	t_d	N_d		
Impact effect	T_e	t_e	N_e		

2.3 Calculation of the load torque, the speed and the service life

Calculation of the load torque

- $T_{av} \leq$ Permissible maximum value of the average load torque



Confirmation

- $T_a, T_b \leq$ Permissible peak torque during start/stop



Confirmation

- $T_e \leq$ Permissible maximum instantaneous torque



Calculation

- $n_{av} \leq$ Permissible average input speed
- $n_{max} \leq$ Permissible maximum input speed



Calculation

- $L_{10} \leq$ Nominal service life of the gear unit 7,000 hours,
Nominal service life of the gear unit at L_{50} 35,000 hours
- Determine the required service life, taking into account the load torque and the input speed

2.3.1 Maximum permissible value of the average load torque

When the input speed or load torque changes, please calculate the average load torque and confirm whether it is in accordance with the values in the nominal power table of each specification. Please note that a value exceeding the catalogue value may cause premature ageing of the lubricant and abnormal gear wheel wear due to heat.

F.2.1

$$T_{av} = \sqrt[3]{\frac{N_1 t_1 |T_1|^3 + N_2 t_2 |T_2|^3 + \dots + N_n t_n |T_n|^3}{N_1 t_1 + N_2 t_2 + \dots + N_n t_n}}$$

2.3.2 Permissible peak torque during start/stop

During starting and stopping, a load greater than the average torque is applied to the gear unit due to the moment of inertia of the load.

2.3.3 Permissible maximum instantaneous torque

The permissible maximum instantaneous torque is the maximum permissible load torque in the event of an impact.

2.3.4 Permissible average input speed and permissible maximum input speed

When setting the operating conditions of the gear unit, do not exceed the value specified in the nominal power table.

DATORKER® strain wave gears

Selection principle

Calculation of the average output speed

F 2.2

$$N_{av} = \frac{N_1 t_1 + N_2 t_2 + \dots + N_n t_n}{t_1 + t_2 + \dots + t_n}$$

Calculation of the average input speed

F 2.3

$$n_{av} = N_{av} \times R$$

R = Reduction ratio

Calculation of the maximum input speed

F 2.4

$$n_{max} = N_{max} \times R$$

2.3.5 Nominal service life of the gear unit

The service life of the gear unit depends on the flexible bearing of the shaft generator. The nominal service life of the shaft generator is 35,000 hours. The calculation formula is as follows:

F 2.5

$$L_{50} = 35.000 \times \left(\frac{T_r}{T_{av}} \right) \times \left(\frac{n_r}{n_{av}} \right)$$

T_r = Nominal torque

n_r = Nominal speed

F 2.6

$$L_{10} = \frac{L_{50}}{5}$$

2.4 Selection of DATORKER® shaft gear unit design and specification

Select the DATORKER® shaft gear unit design according to the operating requirements and check the nominal power table of each unit according to the calculation results from the previous step to confirm whether the selected model specifications match the application. If the gear unit contains a crossed roller bearing, please proceed to the next step and calculate the service life of the crossed roller bearing.

2.5 Calculation of the service life of the crossed roller bearing

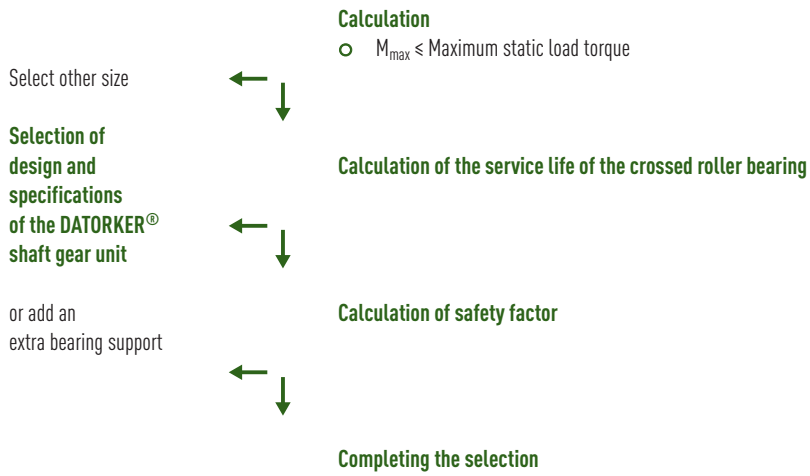

2.6 Calculation of efficiency

Due to the mechanical properties of the gear unit, the efficiency changes depending on various factors. These include, above all, the speed, the temperature and the load ratio under which the gear unit is used. To be sure that the motor is correctly dimensioned, always start from the most unfavourable conditions. The graphs for determining the efficiency can be found in the technical data of the respective series.

DATORKER® strain wave gears

Selection principle

2.7 Order code DATORKER® strain wave gears

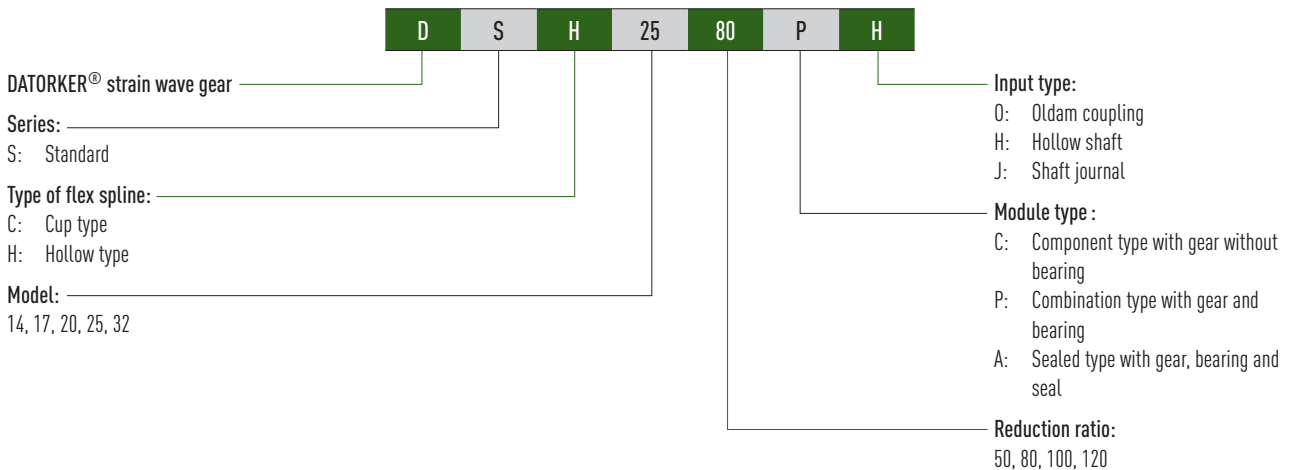

2.8 Type/Function

DSC-PO

- Combination type (P) with gear and bearing
- Connection by oldam coupling
- Whitstand axial and radial load
- Reduced backlash



DSC-CO

- Component type (C) with gear without bearing
- Connection by oldam coupling
- Self-assembly of parts required: flex spline and circular spline are not screwed together
- Reduced backlash



DSH-PH

- Combination type (P) with gear and bearing
- Input hollow shaft design
- Whitstand axial and radial load
- Zero backlash



DSH-AH

- Sealed type (A) with gear, bearing and seal
- Input hollow shaft design
- Whitstand axial and radial load
- Zero backlash
- Completely sealed design
- User friendly design



2.9 Technical data

2.9.1 Specification Table

Table 2.2 Specification Table

Model	Reduction Ratio	Rated torque at input 2000 r/min	Peak torque at start / stop	Permissible max. of value of average load torque	Permissible impact torque	Permissible maximum input speed	Permissible average input speed
		Nm	Nm	Nm	Nm	r/min	r/min
14	50	5.4	18.0	6.9	35.0	8,500	3,500
	80	7.8	23.0	11.0	47.0		
	100	7.8	28.0	11.0	54.0		
17	50	16.0	34.0	26.0	70.0	7,300	3,500
	80	22.0	43.0	27.0	87.0		
	100	24.0	54.0	39.0	108.0		
	120	24.0	54.0	39.0	86.0		
20	50	25.0	56.0	34.0	98.0	6,500	3,500
	80	34.0	74.0	47.0	127.0		
	100	40.0	82.0	49.0	147.0		
	120	40.0	87.0	49.0	147.0		
25	50	39.0	98.0	55.0	186.0	5,600	3,500
	80	63.0	137.0	87.0	255.0		
	100	67.0	157.0	108.0	284.0		
	120	67.0	167.0	108.0	304.0		
32	50	76.0	216.0	108.0	382.0	4,800	3,500
	80	118.0	304.0	167.0	568.0		
	100	137.0	333.0	216.0	647.0		
	120	137.0	353.0	216.0	686.0		

2.9.2 Reduction ratio and rotation direction

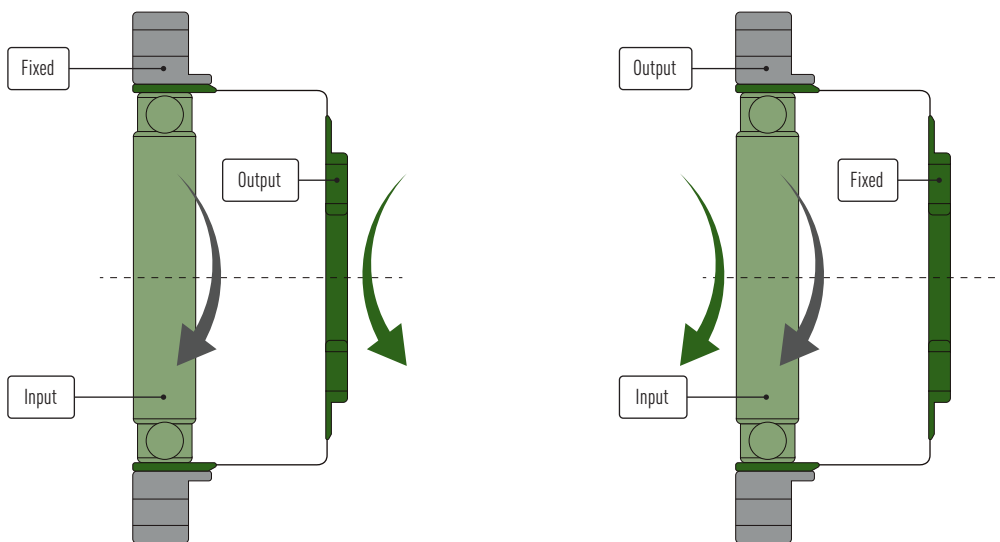

Input and Output with reverse direction rotation

Effective reduction ratio = $(-1) \times R$

(R = Reduction ratio from Datasheet)

Input and Output with the same direction rotation

Effective reduction ratio = $R + 1$

DATORKER® strain wave gears

DSC-PO with motor

3. DSC-PO with motor

The motor adapters for the DATORKER® strain wave gear type DSC-PO allow a simple and compact connection of the HIWIN servo motors together with the HIWIN drive amplifiers and all necessary cables.

Main features:

- Compact
- High precision
- Easy assembly
- Complete system
- Motors with and without brake
- 23bit absolute (multiturn encoder)
- Step direction, EtherCAT (CoE)

Typical applications:

- Rotary/swivel axis
- Rotary tables
- Robot axes

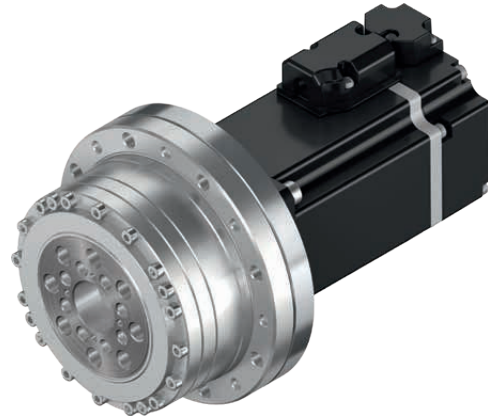

3.1 Technical data

3.1.1 Specification Table

Table 3.1 Specification Table

Model	Reduction Ratio	Peak torque at start/stop	Maximum speed	Rated speed
		Nm	rpm	rpm
WUT20 with 200 W motor	50	56	120	60
	80	74	75	37
	100	82	60	30
WUT25 with 400 W motor	50	98	112	60
	80	137	70	37
	100	157	56	30
WUT32 with 750 W motor	50	216	96	60
	80	304	60	37
	100	333	48	30

Table 3.2 Specification Table (continued)

Model	Maximum current	Rated current	Maximum tilting moment	Moment stiffness	Positioning accuracy	Repeating accuracy	Weight
	A	A	Nm	$\times 10^4$ Nm/rad	arcsec	arcsec	kg
WUT20 with 200 W motor	6.4	1.6	91	12.8	< 60	< ± 6	2.3 (2.6)
WUT25 with 400 W motor	10	2.5	156	24.2			3.3 (3.9)
WUT32 with 750 W motor	18,6	4.65	313	53.9			6.9 (7.6)

Values in brackets apply to model with motor brake

3.2 Dimensions

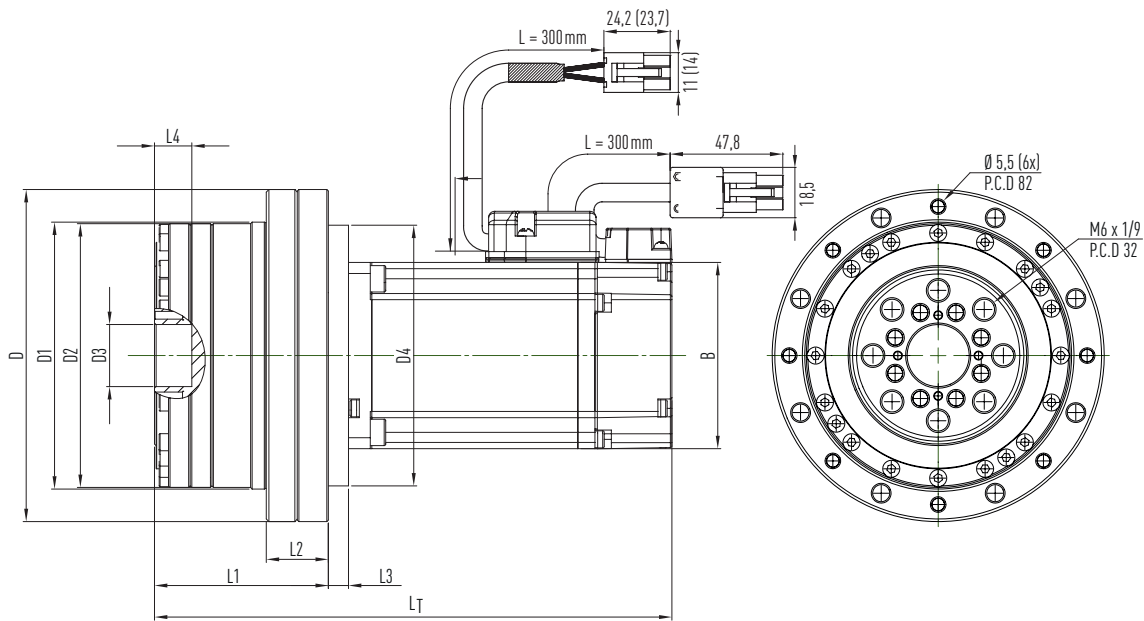

Table 3.3 Dimensions

Model	L _T	L1	L2	L3	L4
WUT20 with 200 W motor	141,9 (171,9)	54,4	26,4	2	9
WUT25 with 400 W motor	166,7 (196,7)	56	20	6,5	12
WUT32 with 750 W motor	203,3 (230,3)	77,5	32,5	3,5	15

Values in brackets apply to model with motor brake

Table 3.4 Dimensions (continued)

Model	D	D1	D2	D3	D4	B
WUT20 with 200 W motor	93	72 ⁰ _{-0,03}	70	14 ^{+0,018} ₀	80 ^{-0,01} _{-0,03}	60
WUT25 with 400 W motor	107	86 ⁰ _{-0,035}	85	20 ^{+0,021} ₀	84 ^{-0,01} _{-0,03}	60
WUT32 with 750 W motor	138	113 ⁰ _{-0,035}	112	26 ^{+0,021} ₀	108 ^{-0,01} _{-0,03}	80

DATORKER® strain wave gears

DSC-PO

4. DSC-PO

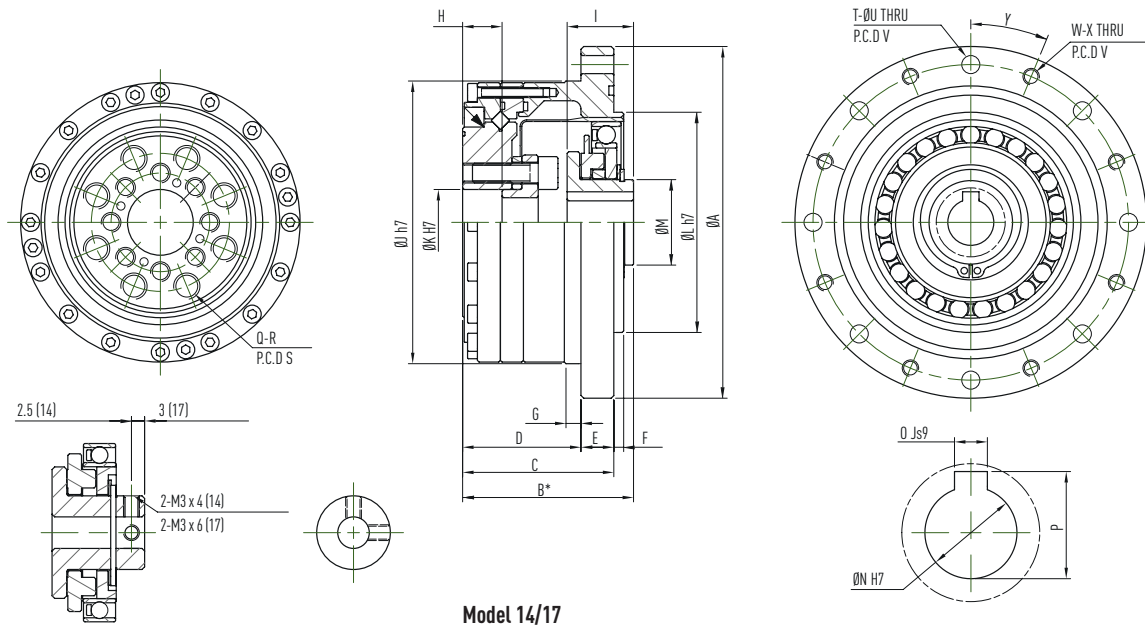

Table 4.1 Dimensions of DSC-PO strain wave gears

Model	Unit	14	17	20	25	32
ØA	mm	73.0	79.0	93.0	107.0	138.0
B ¹⁾	mm	41.0 ^{-0.9}	45.0 ^{-0.9}	45.5 ^{-1.0}	52.0 ^{-1.0}	62.0 ^{-1.1}
C	mm	34.0	37.0	38.0	46.0	57.0
D	mm	27.0	29.0	28.0	36.0	45.0
E	mm	7.0	8.0	10.0	10.0	12.0
F	mm	2.0	2.0	3.0	3.0	3.0
G	mm	3.5	4.0	5.0	5.0	5.0
H	mm	9.4	9.5	9.0	12.0	15.0
I	mm	17.6 ^{-0.1}	19.5 ^{-0.1}	20.1 ^{-0.1}	20.2 ^{-0.1}	22.0 ^{-0.1}
ØJ h7	mm	56.0	63.0	72.0	86.0	113.0
ØK H7	mm	11.0	10.0	14.0	20.0	26.0
ØL h7	mm	38.0	48.0	56.0	67.0	90.0
ØM	mm	14.0	18.0	21.0	26.0	26.0
ØN H7	mm	6.0	8.0	12.0	14.0	14.0
O Js9	mm	-	-	4.0	5.0	5.0
P	mm	-	-	13.8 ^{+0.1}	16.3 ^{+0.1}	16.3 ^{+0.1}
Q	mm	6.0	6.0	8.0	8.0	8.0
R	mm	M4 x 8DP	M5 x 10DP	M6 x 9DP	M8 x 12DP	M10 x 15DP
S (P.C.D)	mm	23.0	27.0	32.0	42.0	55.0
T	mm	6.0	6.0	6.0	8.0	12.0
ØU	mm	4.5	4.5	5.5	5.5	6.6
V (P.C.D)	mm	65.0	71.0	82.0	96.0	125.0
W	mm	6.0	6.0	6.0	8.0	12.0
X	mm	M4	M4	M5	M5	M6
Y	Degree	30°	30°	30°	22.5°	15°
Moment of inertia	×10 ⁻⁴ kgm ²	0.033	0.079	0.193	0.413	1.69
Weight	kg	0.52	0.68	0.98	1.5	3.2

¹⁾ B is the tolerance and the matching position of axial direction.

4.1 DSC-PO design

4.1.1 Technical data

Table 4.2 Crossed roller bearing specifications

Model	Centre circle diameter of the rollers	Offset	Basic load ratings		Permitted torque	Moment rigidity
	Dpw	R	Dynamic load C_{dyn}	Static load C_0		
	m	m	kN	kN		
14	0.0350	0.0095	4.7	6.1	41	4.38
17	0.0425	0.0095	5.3	7.6	64	7.75
20	0.0500	0.0095	5.8	9.0	91	12.80
25	0.0620	0.0115	9.6	15.1	156	24.20
32	0.0800	0.0130	15.0	25.0	313	53.90

Table 4.3 Accuracy of angular transmission

Reduction ratio		Model				
		14	17	20	25	32
50 – 120	$\times 10^{-4}$ rad	4.4	4.4	2.9	2.9	2.9

Table 4.4 Hysteresis loss

Reduction ratio		Model				
		14	17	20	25	32
50	$\times 10^{-4}$ rad	5.8	5.8	5.8	5.8	5.8
80 – 120	$\times 10^{-4}$ rad	2.9	2.9	2.9	2.9	2.9

Table 4.5 Starting torque

Reduction ratio		Model				
		14	17	20	25	32
50		4.1	6.1	7.8	15.0	31
80		2.8	4.0	4.9	9.2	19
100		2.5	3.4	4.3	8.0	18
120		—	3.1	3.8	7.3	15

Unit: cNm

Note: The values in this table vary depending on the working conditions and are for reference purposes only. The upper limit is 20% above the value in this table.

Table 4.6 Reverse starting torque

Reduction ratio		Model				
		14	17	20	25	32
50		1.6	3.0	4.7	9.0	18
80		1.6	3.0	4.8	9.1	19
100		1.8	3.3	5.1	9.8	20
120		—	3.5	5.5	11.0	22

Unit: Nm

Note: The values in this table vary depending on the working conditions and are for reference purposes only. The upper limit is 20% above the value in this table.

DATORKER® strain wave gears

DSC-PO

Reduction ratio		Model					
		14	17	20	25	32	
T1	Nm	2.0	3.9	7.0	14.0	29.0	
T2	Nm	6.9	12.0	25.0	48.0	108.0	
50	K ₁	×10 ⁴ Nm/rad	0.34	0.81	1.3	2.5	5.4
	K ₂	×10 ⁴ Nm/rad	0.47	1.1	1.8	3.4	7.8
	K ₃	×10 ⁴ Nm/rad	0.57	1.3	2.3	4.4	9.8
	θ ₁	×10 ⁻⁴ rad	5.8	4.9	5.2	5.5	5.5
	θ ₂	×10 ⁻⁴ rad	16.0	12.0	15.4	15.7	15.7
80 – 120	K ₁	×10 ⁴ Nm/rad	0.47	1.0	1.6	3.1	6.7
	K ₂	×10 ⁴ Nm/rad	0.61	1.4	2.5	5.0	11.0
	K ₃	×10 ⁴ Nm/rad	0.71	1.6	2.9	5.7	12.0
	θ ₁	×10 ⁻⁴ rad	4.1	3.9	4.4	4.4	4.4
	θ ₂	×10 ⁻⁴ rad	12.0	9.7	11.3	11.1	11.6

The values are for reference purposes only. The lower limit is 20% below the value in this table.

4.1.2 Efficiency E_R

The efficiency of DATORKER® shaft gear units changes depending on the specification, load ratio, operating conditions (speed/load) and lubrication (lubricant type/amount).

E_R = Efficiency at nominal torque
T = Temperature

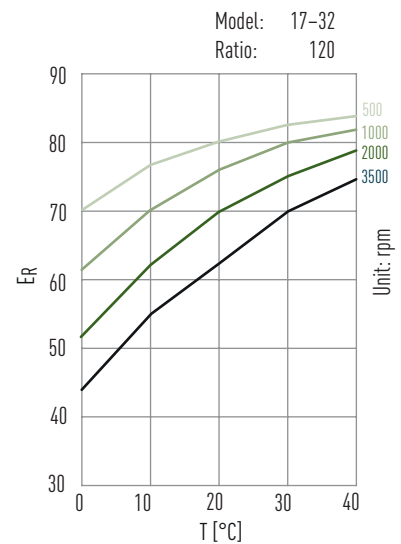
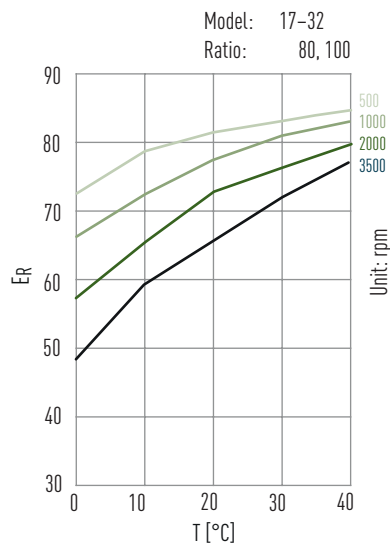
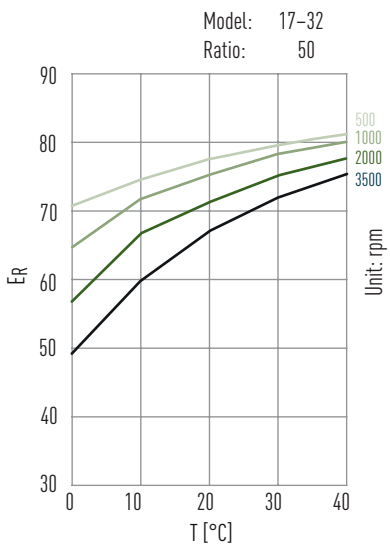
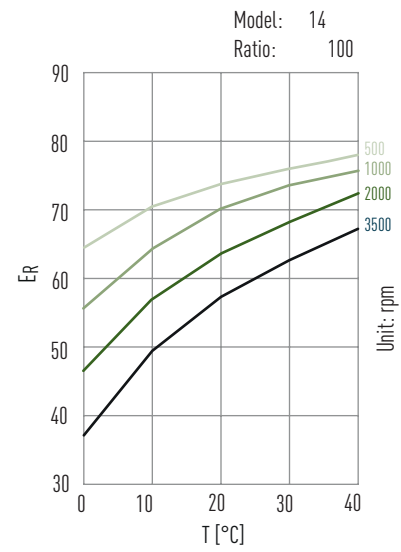
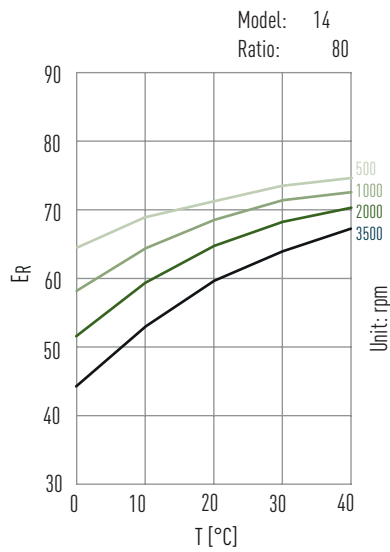
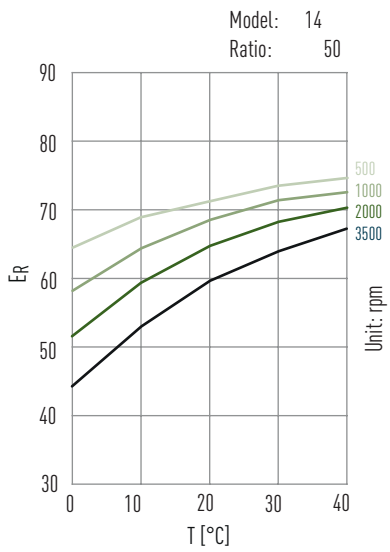

Correction coefficient α

$$\text{Efficiency} = \alpha \times E_R$$

α = Correction coefficient

E_R = Efficiency at nominal torque

T_{av} = Average load torque

T_n = Rated torque

T_{av}/T_n = Torque ratio

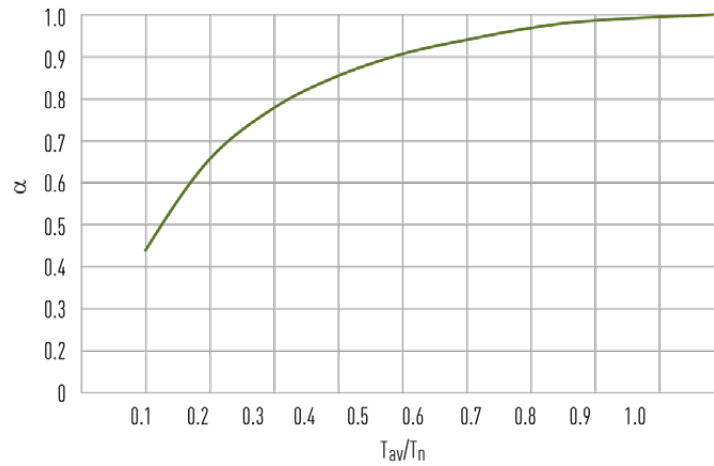

4.1.3 Idling operating torque

The idling operating torque is the torque required to drive the DATORKER® shaft gear input (high speed end) after more than 2 hours at an input speed of 2,000 rpm at an average ambient temperature of 25 °C without load.

Table 4.8 Idling operating torque

Reduction ratio	Input speed	Model				
		14	17	20	25	32
50	500 rpm	3.2	5.1	7.3	12.8	26.1
	1,000 rpm	3.9	6.1	9.1	17.8	33.1
	2,000 rpm	4.6	7.6	11.8	21.8	44.1
	3,500 rpm	5.9	9.6	12.7	28.8	57.1
80	500 rpm	2.3	3.8	5.5	9.7	20.3
	1,000 rpm	3.0	4.8	7.3	14.7	27.3
	2,000 rpm	3.7	6.3	10.0	18.7	38.3
	3,500 rpm	5.0	8.3	10.9	25.7	51.3
100	500 rpm	2.1	3.5	5.0	9.0	19.0
	1,000 rpm	2.8	4.5	6.8	14.0	26.0
	2,000 rpm	3.5	6.0	9.5	18.0	37.0
	3,500 rpm	4.8	8.0	10.4	25.0	50.0
120	500 rpm	-	3.3	4.7	8.5	18.1
	1,000 rpm	-	4.3	6.5	13.5	25.1
	2,000 rpm	-	5.8	9.2	17.5	36.1
	3,500 rpm	-	7.8	10.1	24.5	47.2

Unit: cNm

Note: The values in this table vary depending on the working conditions and are for reference purposes only. The upper limit is 20% above the value in this table.

DATORKER® strain wave gears

DSC-CO

5. DSC-CO

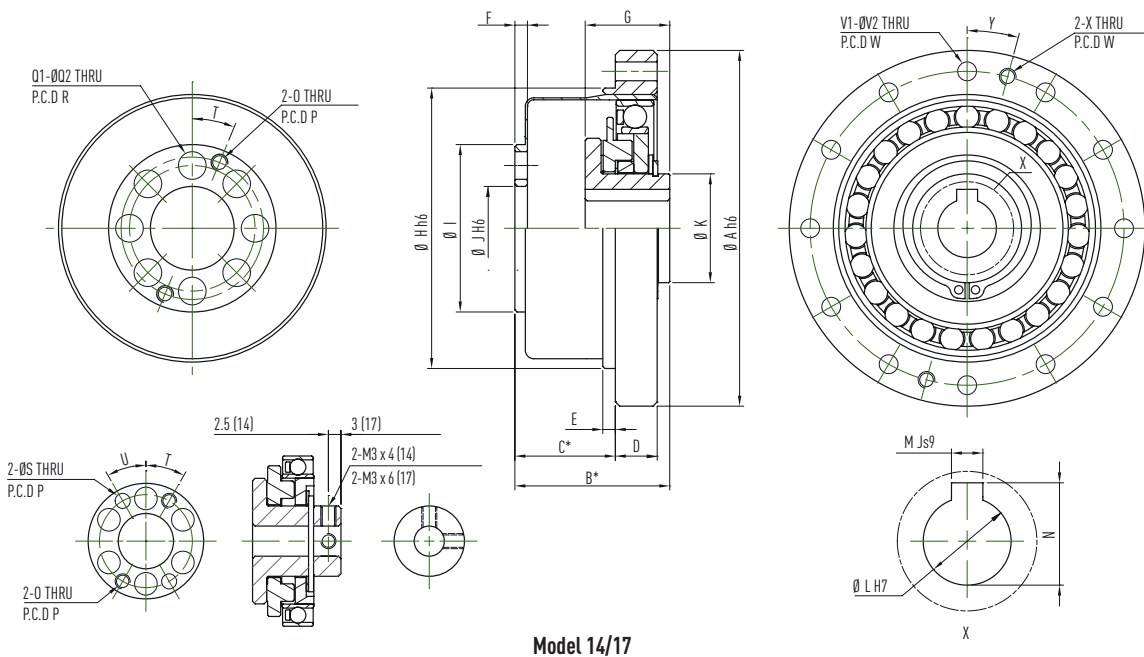

Model 14/17

Table 5.1 Dimensions of DSC-CO strain wave gears

Model	Unit	14	17	20	25	32
ØA h6	mm	50.0	60.0	70.0	85.0	110.0
B ¹⁾	mm	28.5 _{-0.8}	32.5 _{-0.9}	33.5 _{-1.0}	37.0 _{-1.0}	44.0 _{-1.1}
C ¹⁾	mm	17.5 ^{+0.4}	20.0 ^{+0.5}	21.5 ^{+0.6}	24.0 ^{+0.6}	28.0 ^{+0.6}
D	mm	6.0	6.5	7.5	10.0	14.0
E	mm	2.0	2.5	3.0	3.0	3.0
F	mm	2.4	3.0	3.0	3.0	3.2
G	mm	17.6 _{-0.1}	19.5 _{-0.1}	20.1 _{-0.1}	20.2 _{-0.1}	22.0 _{-0.1}
ØH h6	mm	38.0	48.0	54.0	67.0	90.0
ØI	mm	23.0	27.2	32.0	40.0	52.0
J H6	mm	11.0	10.0	16.0	20.0	26.0
ØK	mm	14.0	18.0	21.0	26.0	26.0
ØL H7	mm	6.0	8.0	9.0	11.0	14.0
M Js9	mm	-	-	3.0	4.0	5.0
N	mm	-	-	10.4 ^{+0.1}	12.8 ^{+0.1}	16.3 ^{+0.1}
O	mm	M3	M3	M3	M4	M5
P (P.C.D)	mm	18.5	21.5	27.0	34.0	45.0
Q1	mm	6.0	6.0	8.0	8.0	8.0
ØQ2	mm	4.5	5.5	5.5	6.6	9.0
R (P.C.D)	mm	17.0	19.0	24.0	30.0	40.0
S	mm	3.0 ^{+0.015}	3.0 ^{+0.015}	-	-	-
T	Degree	30°	30°	22.5°	22.5°	22.5°
U	Degree	30°	30°	-	-	-
V1	mm	6.0	12.0	12.0	12.0	12.0
ØV2	mm	3.5	3.5	3.5	4.5	5.5
W (P.C.D)	mm	44.0	54.0	62.0	75.0	100.0
X	mm	M3	M3	M3	M4	M5
Y	Degree	30°	15°	15°	15°	15°
Moment of inertia	×10 ⁻⁴ kgm ²	0.033	0.079	0.193	0.413	1.69
Weight	kg	0.09	0.15	0.28	0.45	0.89

¹⁾ B and C is the tolerance and the matching position of axial direction

5.1 DSC-CO design

5.1.1 Technical data

Reduction ratio		Model				
		14	17	20	25	32
50 – 120	$\times 10^{-4}$ rad	4.4	4.4	2.9	2.9	2.9

Reduction ratio		Model				
		14	17	20	25	32
50	$\times 10^{-4}$ rad	5.8	5.8	5.8	5.8	5.8
80 – 120	$\times 10^{-4}$ rad	2.9	2.9	2.9	2.9	2.9

Reduction ratio		Model				
		14	17	20	25	32
50		3.3	5.1	6.6	12.0	26
80		2.4	3.3	4.1	7.7	16
100		2.1	2.9	3.7	6.9	15
120		–	2.7	3.3	6.3	13

Unit: cNm

Note: The values in this table vary depending on the working conditions and are for reference purposes only. The upper limit is 20% above the value in this table.

Reduction ratio		Model				
		14	17	20	25	32
50		1.4	2.5	4.0	7.5	16
80		1.4	2.5	4.2	7.7	16
100		1.7	2.8	4.5	8.4	18
120		–	3.1	4.9	9.2	19

Unit: Nm

Note: The values in this table vary depending on the working conditions and are for reference purposes only. The upper limit is 20% above the value in this table.

DATORKER® strain wave gears

DSC-CO

Reduction ratio		Model					
		14	17	20	25	32	
T1	Nm	2.0	3.9	7.0	14.0	29.0	
T2	Nm	6.9	12.0	25.0	48.0	108.0	
50	K ₁	×10 ⁴ Nm/rad	0.34	0.81	1.3	2.5	5.4
	K ₂	×10 ⁴ Nm/rad	0.47	1.1	1.8	3.4	7.8
	K ₃	×10 ⁴ Nm/rad	0.57	1.3	2.3	4.4	9.8
	θ ₁	×10 ⁻⁴ rad	5.8	4.9	5.2	5.5	5.5
	θ ₂	×10 ⁻⁴ rad	16.0	12.0	15.4	15.7	15.7
80 – 120	K ₁	×10 ⁴ Nm/rad	0.47	1.0	1.6	3.1	6.7
	K ₂	×10 ⁴ Nm/rad	0.61	1.4	2.5	5.0	11.0
	K ₃	×10 ⁴ Nm/rad	0.71	1.6	2.9	5.7	12.0
	θ ₁	×10 ⁻⁴ rad	4.1	3.9	4.4	4.4	4.4
	θ ₂	×10 ⁻⁴ rad	12.0	9.7	11.3	11.1	11.6

The values are for reference purposes only. The lower limit is 20% below the value in this table.

5.1.2 Efficiency E_R

The efficiency of DATORKER® shaft gear units changes depending on the specification, load ratio, operating conditions (speed/load) and lubrication (lubricant type/amount).

E_R = Efficiency at nominal torque
T = Temperature

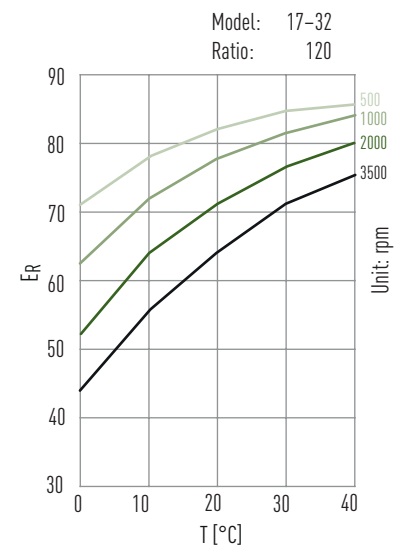
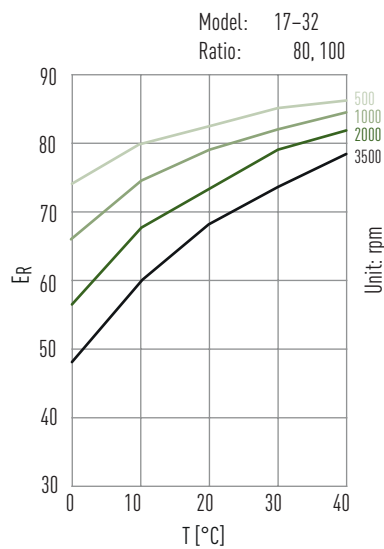
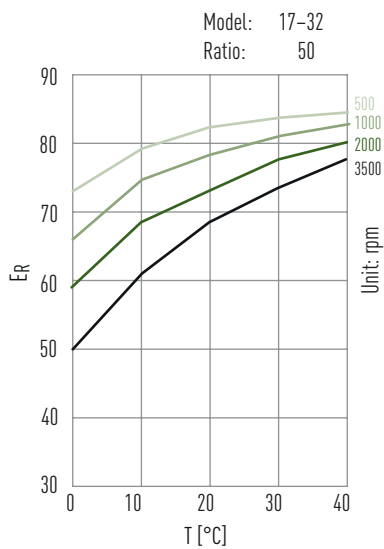
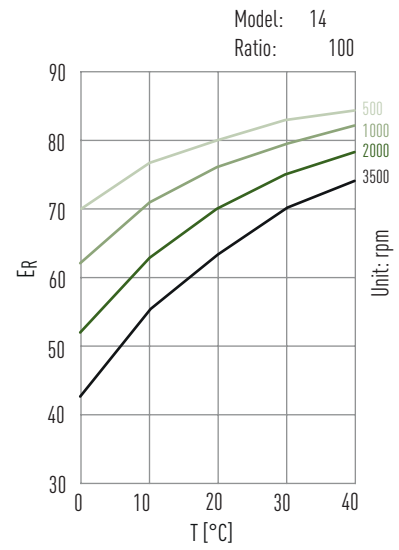
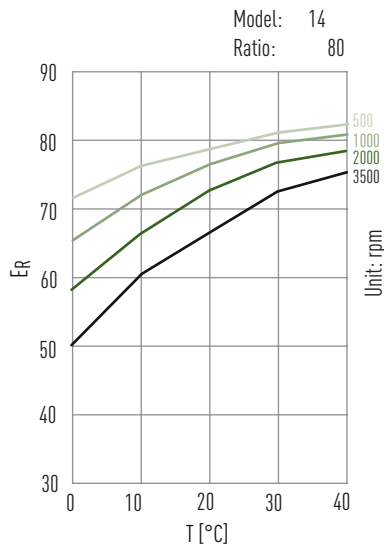
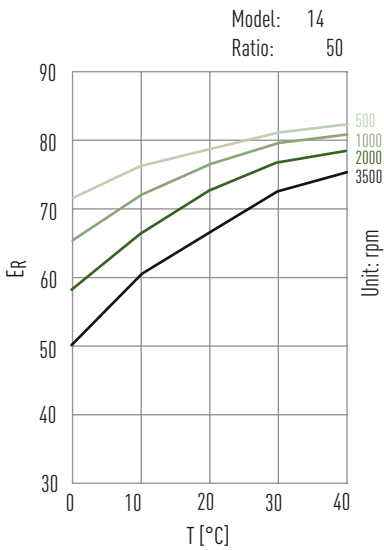

Correction coefficient α

Efficiency = $\alpha \times E_R$

α = Correction coefficient

E_R = Efficiency at nominal torque

T_{av} = Average load torque

T_n = Nominal torque

T_{av}/T_n = Torque ratio

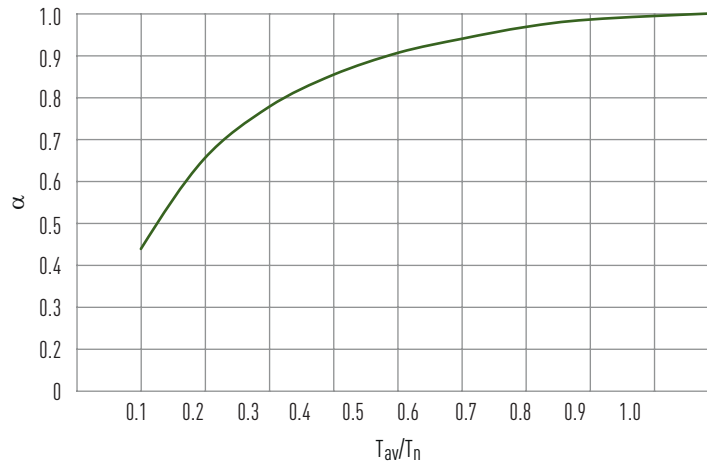

5.1.3 Idling operating torque

The idling operating torque is the torque required to drive the DATORKER® shaft gear input (high speed end) after more than 2 hours at an input speed of 2,000 rpm at an average ambient temperature of 25 °C without load.

Table 5.7 Idling operating torque

Reduction ratio	Input speed	Model				
		14	17	20	25	32
50	500 rpm	1.8	3.4	5.1	9.7	21.2
	1,000 rpm	2.3	4.4	6.9	12.5	27.2
	2,000 rpm	3.1	5.8	9.4	18.5	37.2
	3,500 rpm	4.2	7.9	13.4	25.5	50.2
80	500 rpm	1.4	2.6	3.9	7.6	16.8
	1,000 rpm	1.9	3.6	5.7	10.4	22.8
	2,000 rpm	2.7	5.0	8.2	16.4	32.8
	3,500 rpm	3.8	7.1	12.2	23.4	45.8
100	500 rpm	1.3	2.5	3.7	7.2	16.0
	1,000 rpm	1.8	3.5	5.5	10.0	22.0
	2,000 rpm	2.6	4.9	8.0	16.0	32.0
	3,500 rpm	3.7	7.0	12.0	23.0	45.0
120	500 rpm	-	2.4	3.5	6.9	15.4
	1,000 rpm	-	3.4	5.2	9.7	21.4
	2,000 rpm	-	4.8	7.8	15.7	31.4
	3,500 rpm	-	6.9	11.8	22.7	44.4

Unit: cNm

Note: The values in this table vary depending on the working conditions and are for reference purposes only. The upper limit is 20% above the value in this table.

DATORKER® strain wave gears

DSH-PH

6. DSH-PH

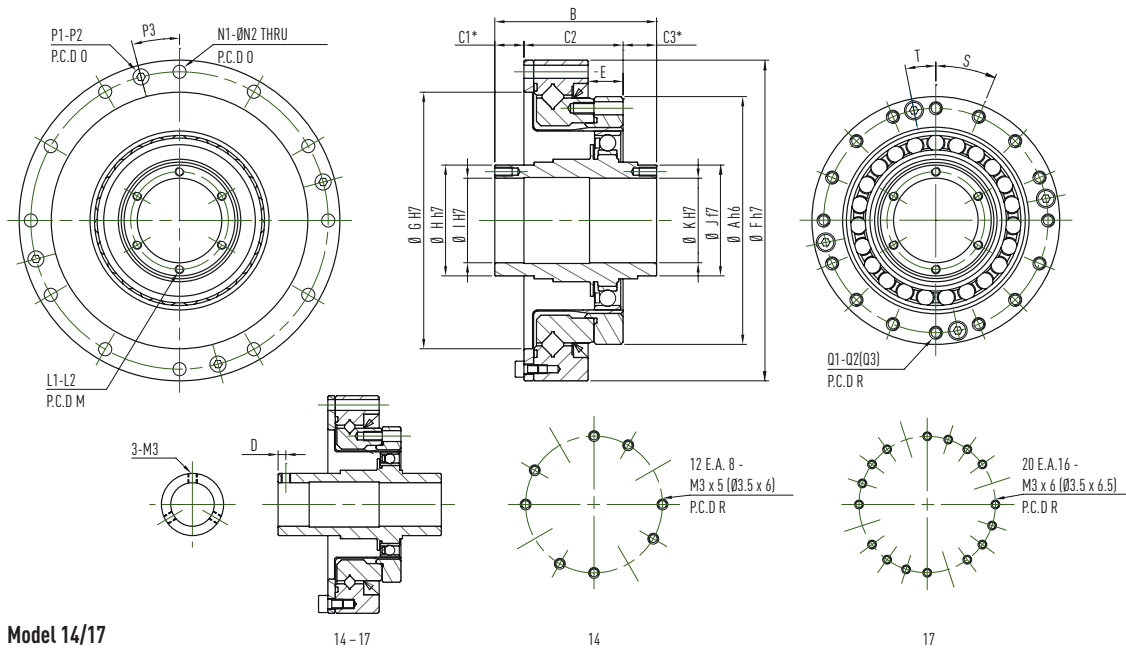

Model 14/17

Table 6.1 Dimensions of DSH-PH strain wave gears

Model	Unit	14	17	20	25	32
ØA h6	mm	50.0	60.0	70.0	85.0	110.0
B	mm	52.5 ^{-0.1}	56.5 ^{-0.1}	51.5 ^{-0.1}	52.0 ^{-1.0}	62.0 ^{-1.1}
C1 ¹⁾	mm	16.0 ^{+0.8}	16.0 ^{+0.9}	9.5 ^{+1.0}	10.0 ^{+1.1}	12.0 ^{+1.1}
C2	mm	23.5	26.5	29.0	34.0	42.0
C3 ¹⁾	mm	13.0	14.0	13.0	11.5	11.5
D	mm	2.5	2.5	-	-	-
E	mm	7.0	7.5	8.5	12.0	15.0
ØF h7	mm	70.0	80.0	90.0	110.0	142.0
ØG H7	mm	48.0	60.0	70.0	88.0	114.0
ØH h7	mm	20.0	25.0	30.0	38.0	45.0
ØI H7	mm	14.0	19.0	21.0	29.0	36.0
ØJ f7	mm	20.0	25.0	30.0	38.0	45.0
ØK H7	mm	14.0	19.0	21.0	29.0	36.0
L1	mm	3.0	3.0	2x6	2x6	2x6
L2	mm	M3	M3	M3 x DP6	M3 x DP6	M3 x DP6
M (P.C.D)	mm	-	-	25.5	33.5	40.5
N1	mm	8.0	12.0	12.0	12.0	12.0
ØN2	mm	3.5	3.5	3.5	4.5	5.5
O (P.C.D)	mm	64.0	74.0	84.0	102.0	132.0
P1	mm	2.0	4.0	4.0	4.0	4.0
P2	mm	M3	M3	M3	M3	M4
P3	Degree	22.5°	15°	15°	15°	15°
Q1	mm	12 E.A. 8	20 E.A. 16	16.0	16.0	16.0
Q2	mm	M3 x 5DP	M3 x 6DP	M3 x 6DP	M4 x 7DP	M5 x 8DP
Q3	mm	Ø3.5 x 6DP	Ø3.5 x 6.5DP	Ø3.5 x 7.5DP	Ø4.5 x 10DP	Ø5.5 x 14DP
ØR	mm	44.0	54.0	62.0	77.0	100.0
S	Degree	30°	18°	22.5°	22.5°	22.5°
T	Degree	30°	18°	11.25°	11.25°	11.25°
Moment of inertia	×10 ⁻⁴ kgm ²	0.033	0.079	0.193	0.413	1.69
Weight	kg	0.45	0.63	0.89	1.44	3.1

¹⁾ C1, C3 is the tolerance and the matching position of axial direction.

6.1 DSH-PH design

6.1.1 Technical data

Table 6.2 **Crossed roller bearing specifications**

Model	Centre circle diameter of the rollers	Offset	Basic load ratings		Permitted torque	Moment rigidity
	Dpw	R	Dynamische Traglast C _{dyn}	Statische Traglast C ₀		
	m	m	kN	kN		
14	0.050	0.0217	5.8	8.6	74	8.5
17	0.060	0.0239	10.4	16.3	124	15.4
20	0.070	0.0255	14.6	22.0	187	25.2
25	0.085	0.0296	21.8	35.8	258	39.2
32	0.111	0.0364	38.2	65.4	580	100.0

Table 6.3 **Accuracy of angular transmission**

Reduction ratio		Model				
		14	17	20	25	32
50 – 120	×10 ⁻⁴ rad	4.4	4.4	2.9	2.9	2.9

Table 6.4 **Hysteresis loss**

Reduction ratio		Model				
		14	17	20	25	32
50	×10 ⁻⁴ rad	5.8	5.8	5.8	5.8	5.8
80 – 120	×10 ⁻⁴ rad	2.9	2.9	2.9	2.9	2.9

Table 6.5 **Starting torque**

Reduction ratio		Model				
		14	17	20	25	32
50		4.1	6.1	7.8	15.0	31
80		2.8	4.0	4.9	9.2	19
100		2.5	3.4	4.3	8.0	18
120		–	3.1	3.8	7.3	15

Unit: cNm

Note: The values in this table vary depending on the working conditions and are for reference purposes only. The upper limit is 20% above the value in this table.

Table 6.6 **Reverse starting torque**

Reduction ratio		Model				
		14	17	20	25	32
50		1.6	3.0	4.7	9.0	18
80		1.6	3.0	4.8	9.1	19
100		1.8	3.3	5.1	9.8	20
120		–	3.5	5.5	11.0	22

Unit: Nm

Note: The values in this table vary depending on the working conditions and are for reference purposes only. The upper limit is 20% above the value in this table.

DATORKER® strain wave gears

DSH-PH

Table 6.7 Torsional rigidity

Reduction ratio			Model				
			14	17	20	25	32
T1		Nm	2.0	3.9	7.0	14.0	29.0
T2		Nm	6.9	12.0	25.0	48.0	108.0
50	K ₁	×10 ⁴ Nm/rad	0.34	0.81	1.3	2.5	5.4
	K ₂	×10 ⁴ Nm/rad	0.47	1.1	1.8	3.4	7.8
	K ₃	×10 ⁴ Nm/rad	0.57	1.3	2.3	4.4	9.8
	θ ₁	×10 ⁻⁴ rad	5.8	4.9	5.2	5.5	5.5
	θ ₂	×10 ⁻⁴ rad	16.0	12.0	15.4	15.7	15.7
80 – 120	K ₁	×10 ⁴ Nm/rad	0.47	1.0	1.6	3.1	6.7
	K ₂	×10 ⁴ Nm/rad	0.61	1.4	2.5	5.0	11.0
	K ₃	×10 ⁴ Nm/rad	0.71	1.6	2.9	5.7	12.0
	θ ₁	×10 ⁻⁴ rad	4.1	3.9	4.4	4.4	4.4
	θ ₂	×10 ⁻⁴ rad	12.0	9.7	11.3	11.1	11.6

The values are for reference purposes only. The lower limit is 20% below the value in this table.

7. DSH-AH

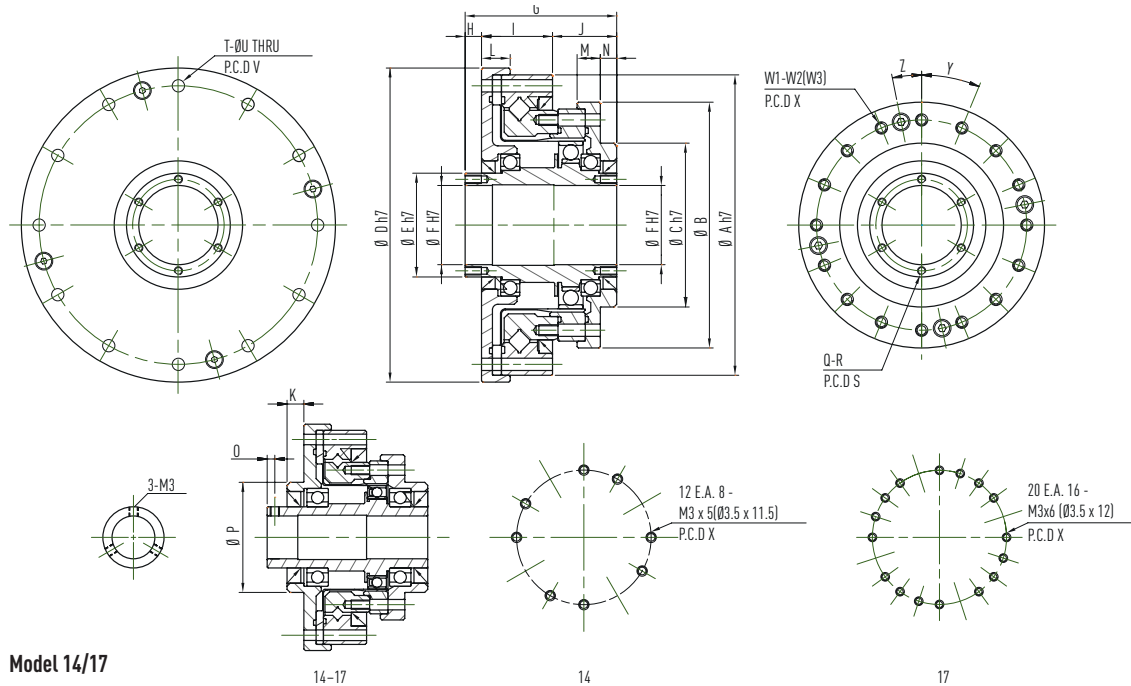

Model 14/17

Model	Unit	14	17	20	25	32
ØA h7	mm	70.0	80.0	90.0	110.0	142.0
ØB	mm	54.0	64.0	75.0	90.0	115.0
ØC h7	mm	36.0	45.0	50.0	60.0	85.0
ØD h7	mm	74.0	84.0	95.0	115.0	147.0
ØE h7	mm	20.0	25.0	30.0	38.0	45.0
ØF H7	mm	14.0	19.0	21.0	29.0	36.0
G	mm	52.5	56.5	51.5	55.5	65.5
H	mm	12.0	12.0	5.0	6.0	7.0
I	mm	20.5	23.0	25.0	26.0	32.0
J	mm	20.0	21.5	21.5	23.5	26.5
K	mm	5.5	5.5	-	-	-
L	mm	9.0	10.0	10.5	10.5	12.0
M	mm	8.0	8.5	9.0	8.5	9.5
N	mm	7.5	8.5	7.0	6.0	5.0
O	mm	2.5	2.5	-	-	-
P	mm	36.0	45.0	-	-	-
Q	mm	3.0	3.0	2x6	2x6	2x6
R	mm	M3	M3	M3 x DP6	M3 x DP6	M3 x DP6
S (P.C.D)	mm	-	-	25.5	33.5	40.5
T	mm	8.0	12.0	12.0	12.0	12.0
ØU	mm	3.5	3.5	3.5	4.5	5.5
V (P.C.D)	mm	64.0	74.0	84.0	102.0	132.0
W1	mm	12 E.A. 8	20 E.A. 16	16.0	16.0	16.0
W2	mm	M3 x 5DP	M3 x 6DP	M3 x 6DP	M4 x 7DP	M5 x 8DP
W3	mm	Ø3.5 x 11.5DP	Ø3.5 x 12DP	Ø3.5 x 13.5DP	Ø4.5 x 15.5DP	Ø5.5 x 20.5DP
X (P.C.D)	mm	44.0	54.0	62.0	77.0	100.0
Y	Degree	30°	18°	22.5°	22.5°	22.5°
Z	Degree	30°	18°	11.25°	11.25°	11.25°
Moment of inertia	×10 ⁻⁴ kgm ²	0.091	0.193	0.404	1.07	2.85
Weight	kg	0.71	1.0	1.38	2.1	4.5

DATORKER® strain wave gears

DSH-AH

7.1 DSH-AH design

7.1.1 Technical data

Model	Centre circle diameter of the rollers	Offset	Basic load ratings		Permitted torque	Moment rigidity
	D _{pw}	R	Dynamic load C _{dyn}	Static load C ₀		
	m	m	kN	kN		
14	0.050	0.0217	5.8	8.6	74	8.5
17	0.060	0.0239	10.4	16.3	124	15.4
20	0.070	0.0255	14.6	22.0	187	25.2
25	0.085	0.0296	21.8	35.8	258	39.2
32	0.111	0.0364	38.2	65.4	580	100.0

Reduction ratio		Model				
		14	17	20	25	32
50 – 120	×10 ⁻⁴ rad	4.4	4.4	2.9	2.9	2.9

Reduction ratio		Model				
		14	17	20	25	32
50	×10 ⁻⁴ rad	5.8	5.8	5.8	5.8	5.8
80 – 120	×10 ⁻⁴ rad	2.9	2.9	2.9	2.9	2.9

Reduction ratio		Model				
		14	17	20	25	32
50		8.8	27	36	56	85
80		7.5	25	33	50	74
100		6.9	24	32	49	72
120		–	24	31	48	68

Unit: cNm

Note: The values in this table vary depending on the working conditions and are for reference purposes only. The upper limit is 20% above the value in this table.

Reduction ratio		Model				
		14	17	20	25	32
50		5.3	16	22	34	51
80		7.2	24	31	48	70
100		8.2	29	38	59	86
120		–	34	45	69	97

Unit: Nm

Note: The values in this table vary depending on the working conditions and are for reference purposes only. The upper limit is 20% above the value in this table.

Table 7.7 Torsional rigidity

Reduction ratio		Model					
		14	17	20	25	32	
T1	Nm	2.0	3.9	7.0	14.0	29.0	
T2	Nm	6.9	12.0	25.0	48.0	108.0	
50	K ₁	×10 ⁴ Nm/rad	0.34	0.81	1.3	2.5	5.4
	K ₂	×10 ⁴ Nm/rad	0.47	1.1	1.8	3.4	7.8
	K ₃	×10 ⁴ Nm/rad	0.57	1.3	2.3	4.4	9.8
	θ ₁	×10 ⁻⁴ rad	5.8	4.9	5.2	5.5	5.5
	θ ₂	×10 ⁻⁴ rad	16.0	12.0	15.4	15.7	15.7
80 – 120	K ₁	×10 ⁴ Nm/rad	0.47	1.0	1.6	3.1	6.7
	K ₂	×10 ⁴ Nm/rad	0.61	1.4	2.5	5.0	11.0
	K ₃	×10 ⁴ Nm/rad	0.71	1.6	2.9	5.7	12.0
	θ ₁	×10 ⁻⁴ rad	4.1	3.9	4.4	4.4	4.4
	θ ₂	×10 ⁻⁴ rad	12.0	9.7	11.3	11.1	11.6

The values are for reference purposes only. The lower limit is 20% below the value in this table.

7.1.2 Efficiency E_R

The efficiency of DATORKER® shaft gear units changes depending on the specification, load ratio, operating conditions (speed/load) and lubrication (lubricant type/amount).

E_R = Efficiency at nominal torque
T = Temperature

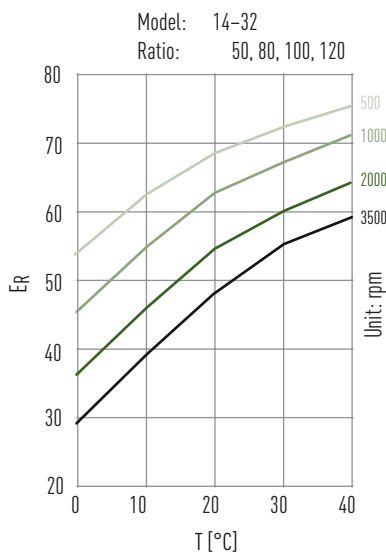

DATORKER® strain wave gears

DSH-AH

Correction coefficient α

Coefficient for correcting the efficiency α according to torque ratio T_{av}/T_n

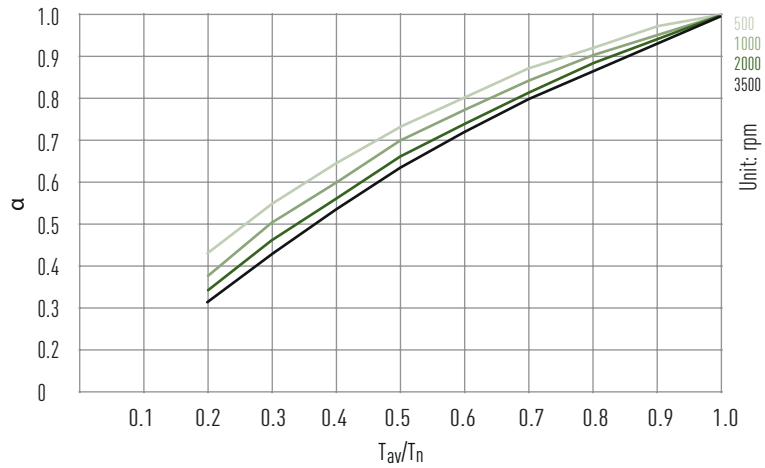

Correction coefficient β

Coefficient for correcting the efficiency β according to specification
Efficiency = $\alpha \times (E_R + \beta)$

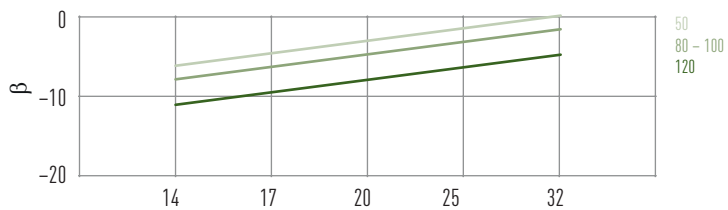

7.1.3 Idling operating torque

The idling operating torque is the torque required to drive the DATORKER® shaft gear input (high speed end) after more than 2 hours at an input speed of 2,000 rpm at an average ambient temperature of 25 °C without load.

Table 7.8 Idling operating torque

Reduction ratio	Input speed	Model				
		14	17	20	25	32
50	500 rpm	6.3	17.8	23.6	37.2	58.0
	1.000 rpm	7.8	21.8	28.6	49.2	76.0
	2.000 rpm	10.1	27.8	37.6	62.2	98.0
	3.500 rpm	14.1	36.8	48.6	89.2	138.0
80	500 rpm	5.4	16.4	21.5	33.8	51.5
	1.000 rpm	6.9	20.4	26.5	45.8	69.5
	2.000 rpm	9.2	26.4	35.5	58.8	91.5
	3.500 rpm	13.2	35.4	46.5	85.8	131.5
100	500 rpm	5.2	16.0	21.0	33.0	50.0
	1.000 rpm	6.7	20.0	26.0	45.0	68.0
	2.000 rpm	9.0	26.0	35.0	58.0	90.0
	3.500 rpm	13.0	35.0	46.0	85.0	130.0
120	500 rpm	-	15.8	20.6	32.4	48.9
	1.000 rpm	-	19.8	25.6	44.4	66.9
	2.000 rpm	-	25.8	34.6	57.4	88.9
	3.500 rpm	-	34.8	45.6	84.4	128.9

Unit: cNm

Note: The values in this table vary depending on the working conditions and are for reference purposes only. The upper limit is 20% above the value in this table.

7.1.4 Permissible input load

The hollow shaft is supported by two deep groove bearings. To ensure proper performance of the gear unit, please confirm the load capacity on the hollow shaft. As shown below:

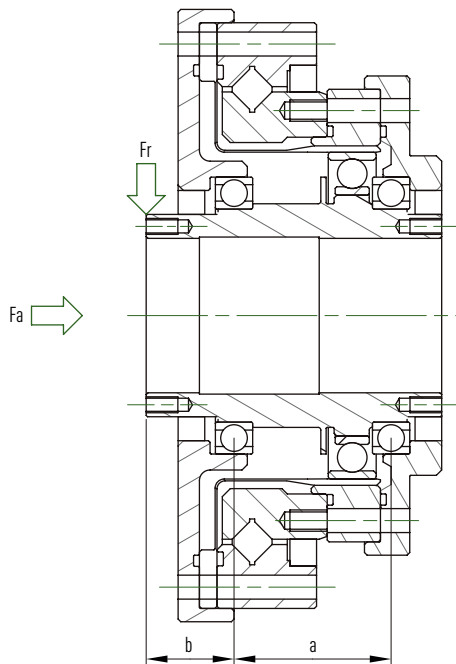

The following figure shows the average input speed of 2,000 rpm and the basic nominal service life $L_{10} = 7,000$ hours.

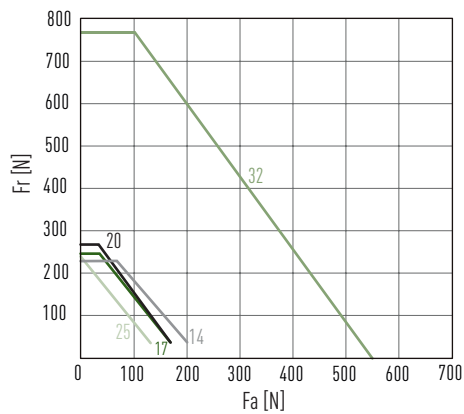

Table 7.9 Specifications of the deep groove ball bearings

Element	Bearing A		Bearing B		a (mm)	b (mm)	Maximum radial load Fr (N) $\times 10^4$ Nm/rad
Model	Dynamic load C_{dyn} (kN)	Static load C_0 (kN)	Dynamic load C_{dyn} (kN)	Static load C_0 (kN)			
14	4.00	2.47	4.00	2.47	27.0	16.5	230
17	4.30	2.95	4.30	2.95	29.0	17.5	250
20	4.50	3.45	4.50	3.45	27.0	15.5	275
25	4.90	4.35	4.90	4.35	29.5	16.5	250
32	14.10	10.90	5.35	5.25	33.0	23.0	770

HIWIN®

GAMB
power transmission

*Rosa de Luxemburg 20 - 2D
08960 - Sant Just Desvern
Barcelona
(SPAIN)*

*Tel. + 34 932529182
Mail: info@gamb.com.es
Web: gamb.com.es*

