

GAMB
power transmission



CONEX



a u t o m a t i o n s y n e r g y

CONEX A

d mm	D mm	B mm	L mm	M mm	T _s Nm	T Nm	F kN	P N/mm ²
17	47	20	26	M 6	16	260	31	104
18	47	20	26	M 6	16	280	31	104
19	47	20	26	M 6	16	290	31	104
20	47	20	26	M 6	16	310	31	104
22	47	20	26	M 6	16	340	31	104
24	50	20	26	M 6	16	370	31	98
25	50	20	26	M 6	16	390	31	98
28	55	20	26	M 6	16	650	46	133
30	55	20	26	M 6	16	700	47	133
32	60	20	26	M 6	16	750	47	122
35	60	20	26	M 6	16	820	47	122
38	65	20	26	M 6	16	1100	58	141
40	65	20	26	M 6	16	1170	59	141
42	75	24	32	M 8	40	1670	80	145
45	75	24	32	M 8	40	1790	80	145
48	80	24	32	M 8	40	1900	79	136
50	80	24	32	M 8	40	1990	80	136
55	85	24	32	M 8	40	2740	100	160
60	90	24	32	M 8	40	2990	100	151
65	95	24	32	M 8	40	3240	100	143
70	110	28	38	M 10	78	5550	159	160
75	115	28	38	M 10	78	5950	159	153
80	120	28	38	M 10	78	6350	159	146
85	125	28	38	M 10	78	6740	159	140
90	130	28	38	M 10	78	7140	159	135
95	135	28	38	M 10	78	9000	189	156
100	145	32	44	M 12	135	11600	232	164
110	155	32	44	M 12	135	12750	232	153
120	165	32	44	M 12	135	14800	247	153
130	180	38	50	M 12	135	20150	310	134
140	190	38	50	M 12	135	23850	341	140
150	200	38	50	M 12	135	27850	371	145
160	210	38	50	M 12	135	32200	403	150
170	225	44	58	M 14	215	40300	475	148
180	235	44	58	M 14	215	46600	518	154
190	250	52	66	M 14	215	57300	604	139
200	260	52	66	M 14	215	71000	711	158
220	285	56	72	M 16	335	93200	849	158
240	305	56	72	M 16	335	117300	979	170

CONEX A

d mm	D mm	B mm	L mm	M mm	T _s Nm	T Nm	F kN	P N/mm ²
260	325	56	72	M 16	335	144000	1110	181
280	355	66	84	M 18	465	177700	1271	158
300	375	66	84	M 18	465	214100	1430	168
320	405	78	98	M 20	660	295800	1852	168
340	425	78	98	M 20	660	314300	1852	160
360	455	90	112	M 22	900	413300	2300	159
380	475	90	112	M 22	900	436300	2300	153
400	495	90	112	M 22	900	459300	2300	147
420	515	90	112	M 22	900	535800	2555	157
440	545	102	130	M 24	1130	647600	2948	149
460	565	102	130	M 24	1130	677000	2948	144
480	585	102	130	M 24	1130	741800	3096	146
500	605	102	130	M 24	1130	809500	3243	148
520	630	102	130	M 24	1130	861000	3317	145
540	650	102	130	M 24	1130	894000	3317	140
560	670	102	130	M 24	1130	989000	3538	146
580	690	102	130	M 24	1130	1067000	3686	148
600	710	102	130	M 24	1130	1103800	3686	143
620	730	102	130	M 24	1130	1186200	3832	145
640	750	102	130	M 24	1130	1271600	3980	147
660	770	102	130	M 24	1130	1359900	4127	148
680	790	102	130	M 24	1130	1401100	4127	144
700	810	102	130	M 24	1130	1545400	4423	150
720	830	102	130	M 24	1130	1589500	4423	147
740	850	102	130	M 24	1130	1688100	4569	149
760	870	102	130	M 24	1130	1789700	4717	149
780	890	102	130	M 24	1130	1865500	4791	149
800	910	102	130	M 24	1130	1942700	4865	148
820	930	102	130	M 24	1130	2051600	5012	149
840	950	102	130	M 24	1130	2163500	5160	150
860	970	102	130	M 24	1130	2278300	5306	151
880	990	102	130	M 24	1130	2396000	5454	152
900	1010	102	130	M 24	1130	2483600	5528	151
920	1030	102	130	M 24	1130	2572600	5602	150
940	1050	102	130	M 24	1130	2697700	5749	151
960	1070	102	130	M 24	1130	2825800	5897	152
980	1090	102	130	M 24	1130	2920700	5970	151
1000	1110	102	130	M 24	1130	3017100	6044	150

T_s (Nm)

Coppia di serraggio viti

Screws tightening torque

T (Nm)

Coppia massima o forza assiale trasmissibili

Transmissible pick torque or axial force

F (kN)

con coppia di serraggio viti T_s

with screws tightening torque T_s

p (N/mm²)

Pressione superficiale sul mozzo

Hub surface pressure

Grandezze superiori su richiesta / Larger sizes upon request

**Non autocentrante
coppie medio-alte**

**Not self centering
medium-high torques**

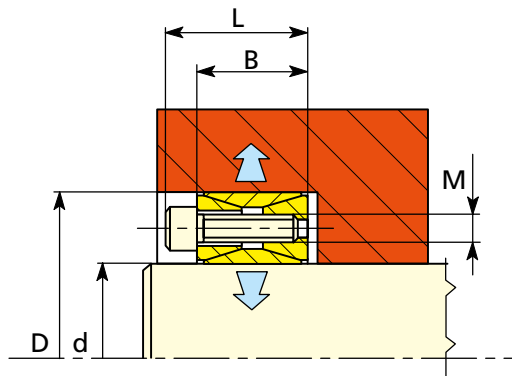

CONEX A (pollici/inch)	d inch	D inch	B inch	L inch	M mm	T_s ft-lb	T ft-lb	F lbs	P psi
3/4	0,750	1,850	0,787	1,023	M 6	11	194	6202	13293
7/8	0,875	1,850	0,787	1,023	M 6	11	226	6202	13293
1	1,000	1,969	0,787	1,023	M 6	11	258	6202	12490
1 1/8	1,125	2,165	0,787	1,023	M 6	11	436	9303	17038
1 3/16	1,188	2,159	0,813	1,049	M 6	11	460	9303	17086
1 1/4	1,250	2,362	0,787	1,023	M 6	11	485	9303	15617
1 3/8	1,375	2,365	0,776	1,012	M 6	11	533	9303	15598
1 7/16	1,438	2,559	0,787	1,023	M 6	11	697	11629	18019
1 1/2	1,500	2,559	0,787	1,023	M 6	11	727	11629	18019
1 5/8	1,625	2,953	0,945	1,260	M 8	27	1186	17516	19993
1 11/16	1,688	2,953	0,945	1,260	M 8	27	1232	17516	19993
1 3/4	1,750	2,953	0,945	1,260	M 8	27	1277	17516	19993
1 7/8	1,875	3,150	0,945	1,260	M 8	27	1368	17516	18742
1 15/16	1,938	3,150	0,945	1,260	M 8	27	1331	16485	17640
2	2,000	3,346	0,945	1,260	M 8	27	1717	20607	20758
2 1/8	2,125	3,346	0,945	1,260	M 8	27	1825	20607	20758
2 3/16	2,188	3,543	0,945	1,260	M 8	27	1878	20607	19604
2 1/4	2,250	3,543	0,945	1,260	M 8	27	1932	20607	19604
2 3/8	2,375	3,531	0,996	1,311	M 8	27	2039	20607	19671
2 7/16	2,438	3,740	0,945	1,260	M 8	27	2093	20607	18571
2 1/2	2,500	3,740	0,945	1,260	M 8	27	2147	20607	18571
2 9/16	2,563	3,737	0,959	1,274	M 8	27	2200	20607	18586
2 5/8	2,625	4,331	1,102	1,496	M 10	52	3404	31118	20169
2 11/16	2,688	4,331	1,102	1,496	M 10	52	3485	31118	20169
2 3/4	2,750	4,337	1,079	1,473	M 10	52	3566	31118	20141
2 7/8	2,875	4,528	1,102	1,496	M 10	52	3728	31118	19291
2 15/16	2,938	4,528	1,102	1,496	M 10	52	3809	31118	19291
3	3,000	4,724	1,102	1,496	M 10	52	3890	31118	18491
3 1/8	3,125	4,724	1,102	1,496	M 10	52	4052	31118	18491
3 1/4	3,250	4,921	1,102	1,496	M 10	52	4214	31118	17751
3 3/8	3,375	4,921	1,102	1,496	M 10	52	4376	31118	17751
3 7/16	3,438	5,118	1,102	1,496	M 10	52	4457	31118	17067
3 1/2	3,500	5,118	1,102	1,496	M 10	52	4538	31118	17067
3 3/4	3,750	5,305	1,142	1,536	M 10	52	5835	37342	19759
3 15/16	3,938	5,708	1,301	1,773	M 12	91	7558	46065	20906
4	4,000	5,843	1,299	1,771	M 12	91	7677	46065	20423
4 7/16	4,438	6,496	1,299	1,771	M 12	91	9085	49136	19594
4 1/2	4,500	6,496	1,299	1,771	M 12	91	9213	49136	19594
4 15/16	4,938	7,087	1,496	1,968	M 12	91	12636	61420	17169
5	5,000	7,087	1,496	1,968	M 12	91	12796	61420	17169
5 1/2	5,500	7,492	1,449	1,921	M 12	91	15483	67562	17865
6	6,000	8,268	1,496	1,968	M 12	91	19961	79846	19132
6 1/2	6,500	8,858	1,732	2,283	M 14	138	23477	86684	17352
7	7,000	9,252	1,732	2,283	M 14	138	27581	94564	18123
7 1/2	7,500	9,823	2,126	2,677	M 14	138	34477	110325	16451
7 7/8	7,875	10,235	2,051	2,602	M 14	138	38786	118205	16917

**Serraggio senza chiave
dinamometrica!**

No need of torque wrench!



I vantaggi del sistema Conex SA-SB rispetto a Conex SD

- Non c'è bisogno di chiave dinamometrica: serrare le viti in sequenza oraria in più passaggi fino a che le facce frontali della flangia e dell'anello esterno sono allineate. Ciò consente la trasmissione delle coppie di catalogo. Da una ricerca di mercato risulta che l'85% dei calettatori installati non viene serrato con chiave dinamometrica. Da test effettuati risulta che un montatore perfettamente addestrato serra le viti a coppie di almeno il 30% inferiori al corrispondente serraggio con chiave dinamometrica. Ne consegue che l'85% dei calettatori installati trasmette una coppia di almeno il 30% inferiore ai dati di catalogo. Conex SA-SB risolve perfettamente il problema, sostituendo a una regolazione di coppia che richiede precisione, una regolazione di posizione che richiede solo l'allineamento di 2 superfici. Inoltre l'intercambiabilità con i tipi tradizionali è garantita.
- Risparmio fino all'80% del tempo di montaggio usando un avvitatore motorizzato.
- Coppie trasmissibili più elevate grazie a viti di diametro più grande.
- Tolleranze geometriche di fabbricazione migliori, una miglior classe di equilibratura; inoltre il serraggio delle due flange in un solo blocco ne garantisce automaticamente il parallelismo, e quindi velocità di lavoro più elevate senza necessità di equilibratura dinamica.

The advantages of the Conex SA-SB system compared to Conex SD

- *No need of a torque wrench: tighten the screws in clockwise sequence in different stages until the front faces of the flange and of the outer ring are aligned. This allows the transmission of the torque values stated on the catalogue charts. According to marketing researches, 85% of assembled clamping elements has not been tightened using a torque wrench. Moreover following to tests, even the best trained fitters tighten the screws at 30% lower torque compared to the catalogue value T_s . As a consequence, 85% of the assembled clamping elements transmit 30% lower torque than the catalogue data.* Conex SA-SB are the perfect solution to the problem by replacing torque setting that requires precision, with position setting that only needs the alignment of two surfaces. Moreover the interchangeability with the traditional types is guaranteed.
- *Saving up to 80% of mounting time if using a powered screwdriver.*
- *Improved and higher transmissible torque thanks to larger screw sizes.*
- *At first the tighter geometrical manufacturing tolerances assure a higher degree of balancing and also the "single block fitting" by aligning the two flanges (flush mounted) automatically guarantees the parallel setting and this will further postpone the need of dynamic balancing.*

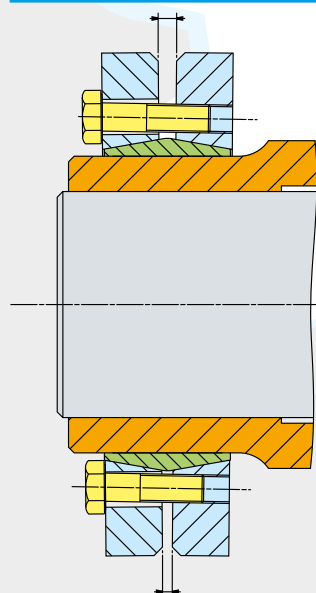

Tipo tradizionale SD:
il serraggio delle due flange non ne garantisce il parallelismo

Traditional Conex SD:
fitting the two flanges does not guarantee their parallel setting

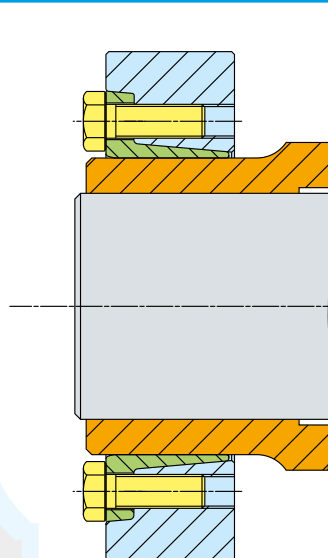

Tipo SA-SB:
dopo il serraggio le due flange formano un unico blocco e quindi è garantito un perfetto parallelismo

Conex SA-SB:
the two flanges create a single block and guarantee the perfect parallel setting after the screw tightening

Esempi di applicazione

Application samples

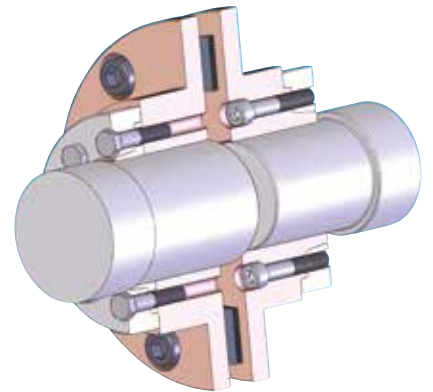
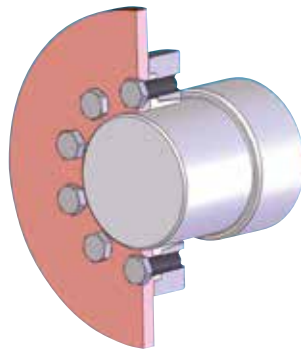
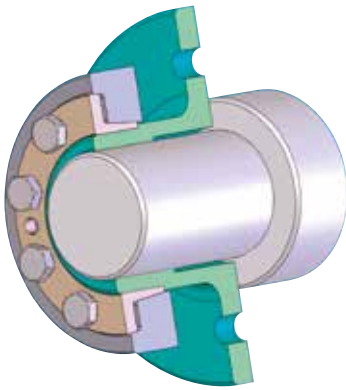

Applicazione speciale per dischi freno, volani, corone dentate, leve, tamburi.

Special application for brake discs, flywheels, chainwheels, levers, drums.

Applicazione speciale per giunti.

Special application for couplings

Per il montaggio senza chiave dinamometrica: serrare le viti e allineare le facce "A" e "B"; a facce allineate la coppia di catalogo può essere trasmessa.

No need for a torque wrench! Tighten the screws and align the 2 faces "A" and "B", then the catalogue torque values can be transmitted.

Sgrassare accuratamente
*Grease free!
Clean using lime milk*

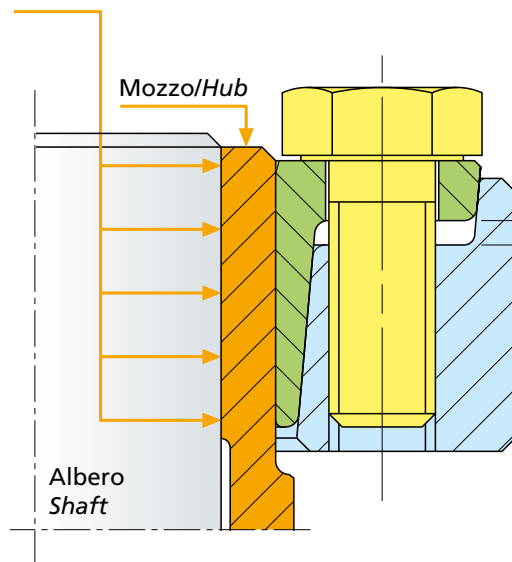

Aria nel calettatore libero, prima del serraggio delle viti
Loose element air gap (before screws tightening)

Faccia frontale della flangia "A"
"A" flange front face

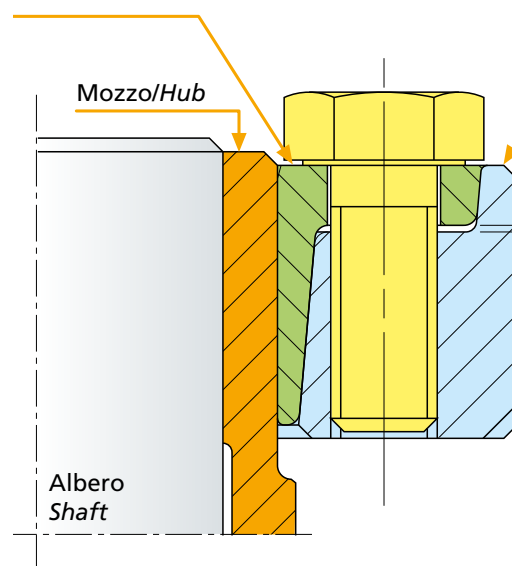

Faccia frontale dell'anello esterno "B"
"B" outer ring front face

Aria nel calettatore dopo serraggio viti
Residual air gap after screws tightening

Lubrificare le superfici coniche e le viti con grasso contenente additivi per alte pressioni (M_oS_2)
Conical surfaces and screws lubricated with grease containing high pressure additives (M_oS_2)

Istruzioni per montaggio e smontaggio Conex SA-SB

- **Immagazzinare e trasportare** i calettatori Conex SA-SB sempre con le viti rivolte verso l'alto.

Montaggio

- Non serrare le viti prima dell'installazione del calettatore (sul mozzo).
- Verificare prima del montaggio che la flangia e l'anello non siano bloccati; se necessario sbloccare la flangia usando le viti d'estrazione.
- Pulire ed oliare leggermente il diametro interno del calettatore e il diametro esterno del mozzo.
- **Condizione essenziale per la trasmissione della coppia di catalogo è la pulizia e lo sgrassaggio della superficie fra albero e mozzo, e il rispetto di tolleranze e rugosità indicate nella tabella dei dati tecnici.**
- Dopo aver assemblato albero e mozzo, posizionare il calettatore e serrare a mano le viti.

Serraggio con chiave dinamometrica

- Serrare tre o quattro viti, approssimativamente equidistanti, con una coppia di circa il 60% della coppia di catalogo, poi serrare tutte le viti in più stadi in sequenza oraria con chiave dinamometrica, fino al raggiungimento e stabilizzazione della coppia di serraggio T_s di catalogo. Assicurarsi che flangia e anello esterno restino paralleli durante l'intero processo di serraggio.
- Con questo tipo di serraggio, la flangia può sporgere dall'anello esterno, a causa delle tolleranze di lavorazione dei singoli componenti.

Serraggio senza chiave dinamometrica

- Serrare tre o quattro viti, approssimativamente equidistanti, con una coppia di circa il 60% della coppia di catalogo, poi serrare tutte le viti in più stadi in sequenza oraria fino ad allineare la flangia con l'anello esterno; in questa condizione il calettatore trasmette la coppia di catalogo. Assicurarsi che flangia e anello esterno restino parallele durante l'intero processo di serraggio.

Smontaggio

- Svitare tutte le viti in sequenza oraria in più stadi fino allo sbloccaggio della flangia e dell'anello.
- Se la flangia e l'anello non si sbloccano, smontare alcune viti e avvitarle nei fori d'estrazione sulla faccia della flangia fino allo sbloccaggio.
- Non rimuovere completamente tutte le viti se la flangia e l'anello non sono sbloccati, perché potrebbero sbloccarsi improvvisamente causando pericolo all'operatore.

Montaggio successivo

- Dopo lo smontaggio e in caso di pulizia, le superfici coniche del calettatore, le viti e il sottotesta delle viti, dovranno essere lubrificate con grasso contenente additivo per alta pressione MoS_2 , per esempio Molykote G-Rapid Plus.

Assembly / disassembly instructions for Conex SA-SB

- **Always store and transport** Conex SA-SB clamping elements with screws up.

Assembly instructions

- **Do not tighten the screws before the clamping element is mounted on the hub.**
- **Verify that flange and outer ring are not blocked before assembling; if necessary release the flange using the extraction screws.**
- **Clean and slightly oil the inner diameter of the clamping element and the outer diameter of the hub.**
- **The essential condition to transmit the catalogue torque values is to clean and degrease the surface between shaft and hub, and to respect tolerances and roughness as indicated on the technical charts.**
- **After having assembled shaft and hub, position the clamping element and tighten the screws by hand.**

Tightening with torque wrench

- **Tighten four screws, approximately equally spaced, with a torque of approximately 60% of the catalogue tightening torque, then tighten all the screws in several steps clockwise with a torque wrench until the tightening torque value T_s of the catalogue is reached and stabilized.**
- **During tightening with torque wrench, the flange can overhang the outer ring, because of the manufacturing tolerances of the single components.**

Tightening without torque wrench

- **Tighten the screws in clockwise sequence in several steps, in order to align the flange and the outer ring surfaces; in this flush mounted condition the clamping element will transmit the catalogue torque value.**

How to disassemble

- **Release all the screws in clockwise sequence in different stages until the flange and the ring are released.**
- **If the flange and the ring do not release, disassemble some screws and tighten them in the extraction holes of the flange surface until it is released.**
- **Do not completely remove all the screws if the flange and the ring are still blocked because they could suddenly release causing danger to the operator.**

Repeated use of the Conex

- **The conical surfaces of the clamping element, the screws and the surface under the screws head must be lubricated with grease containing high pressure additives MoS_2 (such as Molykote G-Rapid Plus). In case of disassembly and cleaning, the cones must be relubricated.**

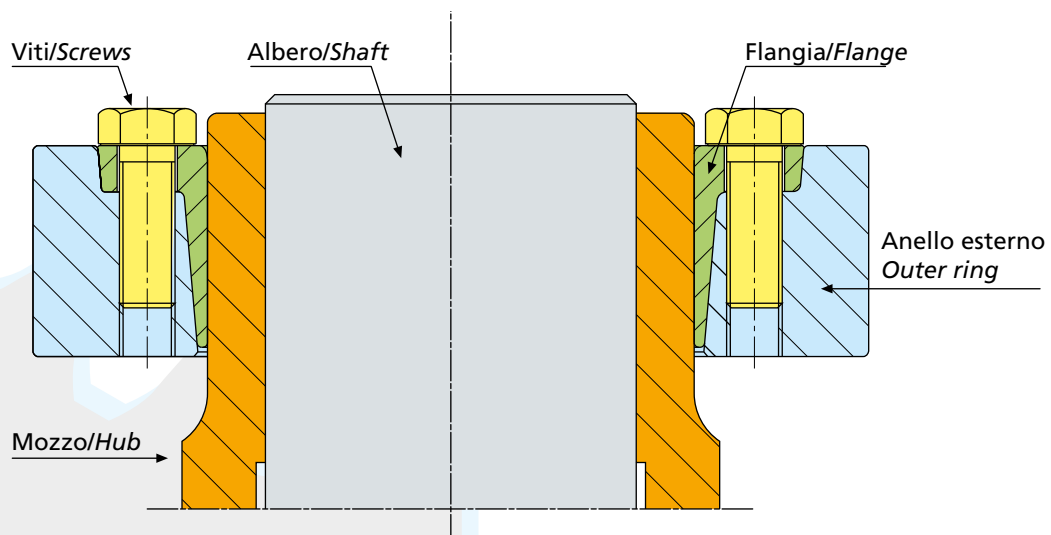

Istruzioni per montaggio e smontaggio Conex SD

Montaggio

- Non serrare le viti prima dell'installazione del calettatore sul mozzo.
- Pulire ed oliare leggermente il diametro interno del calettatore e il diametro esterno del mozzo.
- Condizione essenziale per la trasmissione della coppia di catalogo è la pulizia e lo sgrassaggio della superficie fra albero e mozzo, e il rispetto di tolleranze e rugosità indicate nella tabella dei dati tecnici.
- Dopo aver assemblato albero e mozzo, posizionare il calettatore, posizionare in squadra i due anelli di pressione e serrare a mano le viti.

Serraggio con chiave dinamometrica

- Serrare le viti in più stadi in sequenza oraria con chiave dinamometrica fino al raggiungimento e stabilizzazione della coppia T_s indicata a catalogo.

Smontaggio

- Svitare tutte le viti in sequenza oraria in più stadi, senza smontarle completamente dai fori filettati, fino allo sbloccaggio della flangia e dell'anello.

Montaggio successivo

- Dopo lo smontaggio e in caso di pulizia, le superfici coniche del calettatore, le viti e il sottotesta delle viti, dovranno essere rilubrificate con grasso contenente additivo per alta pressione MoS_2 , per esempio Molykote G-Rapid Plus.

Assembly / disassembly instructions for Conex SD

Assembly instructions

- Do not tighten the screws before the clamping element is mounted on the hub.
- Clean and slightly oil the inner diameter of the clamping element and the outer diameter of the hub.
- The essential condition to transmit the catalogue torque values is to clean and degrease the surface between shaft and hub, and to respect tolerances and roughness as indicated on the technical charts.
- After having assembled shaft and hub, position the clamping element, squarely position the two thrust rings, and tighten the screws by hand.

Tightening with torque wrench

- Tighten the screws in clockwise sequence using the torque wrench in several steps, until the tightening torque value T_s of the catalogue is reached and stabilised.

How to disassemble

- Release all the screws in clockwise sequence in different stages, without take out them completely from the threads, until the flange and the ring are released.

Repeated use of the Conex

- The conical surfaces of the clamping element, the screws and the surface under the screws head must be lubricated with grease containing high pressure additives MoS_2 (such as Molykote G-Rapid Plus). In case of disassembly and cleaning, the cones must be relubricated.

SA-SB-SD

Progettazione del mozzo

Il materiale del mozzo dovrebbe avere un limite di snervamento ($\sigma_{0,2}$) di almeno 350 N/mm², per esempio con l'impiego di acciaio C45. Quando il mozzo trasmette momenti flettenti rotanti significativi, devono essere usati acciai bonificati, come per esempio 42 CrMo4.

Se il materiale del mozzo lo permette, possono essere usati alberi più grandi di quelli indicati nei dati tecnici di catalogo e la maggiore coppia trasmissibile può essere estrapolata.

Tolleranze e qualità delle superfici sono indicate nei disegni sopra le tabelle dei dati tecnici. Il limite di snervamento $\sigma_{0,2}$ del materiale prescelto per il mozzo deve essere maggiore della sollecitazione totale (tangenziale + radiale) σ_v sul mozzo.

Hub calculation

Hub material should have a minimum yield strength ($\sigma_{0,2}$) of 350N/mm², like steel C45.

Heat treated steel like 42 CrMo4 must be used when the hub transmits significant rotating bending moments.

Larger shafts than the ones specified in the technical data can be selected if hub material permits: the correspondent larger transmissible torque can be extrapolated.

Tolerances and surface quality are specified on the drawing on the top of the technical data.

The yield point $\sigma_{0,2}$ of the selected hub material must be higher of the total (tangential + radial) stress σ_v on the hub.

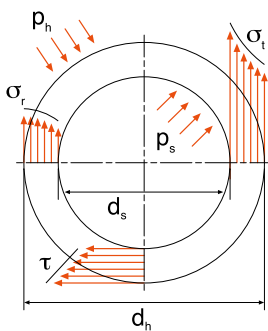

$$\sigma_v = \sqrt{\sigma_t^2 + \sigma_r^2 - \sigma_t \cdot \sigma_r + 3 \tau^2}$$

$$p_s = \frac{2 \cdot T \cdot 10^3}{\pi \cdot d_s^2 \cdot l \cdot \mu}$$

$$p_h = p_s + \frac{\Delta d_s \cdot E \cdot \left[1 - \left(\frac{d_s}{d_h}\right)^2\right]}{2 \cdot d_s}$$

$$\tau = \frac{16 \cdot T \cdot d_s \cdot 10^3}{\pi (d_h^4 - d_s^4)}$$

$$\sigma_t = \frac{p_s \cdot \left[1 + \left(\frac{d_s}{d_h}\right)^2\right] - 2p_h}{1 - \left(\frac{d_s}{d_h}\right)^2}$$

$$\sigma_r = -p_s$$

σ_v [N/mm²] sollecitazione totale sul mozzo / total stress on the hub

σ_t [N/mm²] sollecitazione normale in direzione circonferenziale / normal stress in the circumferential direction

τ [N/mm²] sollecitazione tangenziale sul mozzo / shear stress on the hub

σ_r [N/mm²] sollecitazione radiale sul mozzo / radial stress on the hub

p_s [N/mm²] pressione sull'albero / pressure on the shaft

p_h [N/mm²] pressione sul mozzo / pressure on the hub

d_s [mm] diametro dell'albero / shaft diameter

d_h [mm] diametro del mozzo / hub diameter

T [Nm] coppia massima trasmissibile / maximum transmissible torque

μ [] coefficiente di attrito albero - mozzo / friction coefficient shaft - hub

l [mm] lunghezza assiale del calettatore / axial length of the clamping element

Δd_s [mm] gioco fra albero e mozzo / fit clearance shaft - hub

E [N/mm²] modulo di elasticità / elasticity modulus

CONEX SA

d mm	ds mm	D mm	B mm	L mm	I mm	H mm	M mm	Ts Nm	T Nm	F kN
16	13 - 14	41	15,5	19,5	12,5	1,5	M 6	13	70 - 90	11 - 13
18	15 - 16	44	15,5	19,5	12,5	1,5	M 6	13	80 - 110	11 - 14
20	17 - 18	47	15,5	19,5	12,5	1,5	M 6	13	150 - 180	18 - 20
24	19 - 20 - 22	50	18	22	15	2	M 6	13	165 - 225 - 295	17 - 23 - 27
26	20 - 22 - 24	51,5	18	22	15	2	M 6	13	230 - 300 - 350	23 - 27 - 29
30	24 - 25 - 26	60	20	24	17	2	M 6	13	370 - 420 - 470	31 - 34 - 36
36 38	27 - 30 - 33	72	22	27,5	19	2	M 8	30	480 - 650 - 860	36 - 43 - 52
40	34	80	24	29,5	20,5	2	M 8	30	880	52
44	35 - 37	80	24	29,5	20,5	2	M 8	30	810 - 960	46 - 52
50	38 - 40 - 42	90	26	31,5	22	2,5	M 8	30	1150 - 1300 - 1520	61 - 65 - 72
55	42 - 45 - 48	100	29	34,5	24,5	3	M 8	30	1300 - 1600 - 1900	62 - 71 - 79
60 62	48 - 50 - 52	110	29	34,5	24,5	3	M 8	30	1700 - 1950 - 2160	71 - 78 - 83
68	50 - 55 - 60	115	29,5	35	24,5	3,5	M 8	30	1900 - 2500 - 3150	76 - 91 - 105
75	55 - 60 - 65	138	31	37,5	25	4	M 10	60	2700 - 3400 - 4100	105 - 120 - 132
80	60 - 65 - 70	141	31	37,5	25	4	M 10	60	3300 - 4100 - 4950	110 - 126 - 141
85 90	65 - 70 - 75	155	38	44,5	31,5	4	M 10	60	5500 - 6600 - 7900	169 - 189 - 211
95 100	70 - 75 - 80	170	43,5	50	36,5	4,5	M 10	60	6200 - 7400 - 8600	186 - 197 - 215
105 110	80 - 85 - 90	185	49	56,5	40,5	5,5	M 12	100	10500 - 11800 - 13700	263 - 278 - 304
115 120	85 - 90 - 95	197	53	60,5	45	5	M 12	100	12500 - 14100 - 16000	294 - 313 - 337
125	90 - 95 - 100	215	53,5	61	45	5,5	M 12	100	14500 - 16600 - 18800	322 - 349 - 376
130	95 - 100 - 110	215	53,5	61	45	5,5	M 12	100	17000 - 18400 - 22000	358 - 368 - 400
130 135	95 - 100 - 110	230	57,5	66,5	47	6,5	M 14	160	18400 - 20800 - 26200	387 - 416 - 476
140	100 - 105 - 115	230	58	67	47	7	M 14	160	19900 - 22200 - 27800	398 - 423 - 483
150 155	110 - 120 - 125	263	62	71	51	7,5	M 14	160	27000 - 32000 - 36200	491 - 533 - 579
160 165	120 - 130 - 135	290	68,5	78,5	56	7,5	M 16	250	39000 - 48000 - 51000	650 - 738 - 756
170 175	130 - 140 - 145	300	69	79	56	8	M 16	250	46500 - 53000 - 59000	715 - 757 - 814
180 185	140 - 150 - 155	320	85	95	71,5	7,5	M 16	250	66000 - 76000 - 83000	943 - 1013 - 1071
190 195 200	150 - 160 - 165	340	88	98	71,5	10	M 16	250	82000 - 91000 - 102000	1093 - 1138 - 1236
220	160 - 170 - 180	370	107,5	120	88	11	M 20	480	105000 - 122000 - 138000	1313 - 1435 - 1533
240	170 - 180 - 200	405	111	123,5	92	13	M 20	480	125000 - 145000 - 182000	1471 - 1611 - 1820
260	190 - 200 - 220	430	125,5	138	103	15	M 20	480	165000 - 190000 - 238000	1737 - 1900 - 2164
280	210 - 220 - 240	460	140	152,5	114	19	M 20	480	220000 - 245000 - 300000	2095 - 2227 - 2500
300	220 - 230 - 250	485	140	159	122	16	M 24	840	297000 - 330000 - 399000	2700 - 2870 - 3192
320	240 - 250 - 270	520	141,5	160,5	122	18	M 24	840	331000 - 365000 - 437000	2758 - 2920 - 3237
340	250 - 260 - 280	570	158,5	177,5	137	19	M 24	840	429000 - 469000 - 556000	3432 - 3608 - 3971
360	270 - 280 - 290	590	163	182	140	20	M 24	840	545000 - 592000 - 694000	4037 - 4229 - 4786
390	290 - 300 - 320	650	169	191	144	21	M 27	1250	704000 - 760000 - 879000	4855 - 5067 - 5494
420	320 - 330 - 350	670	186	208	162	20	M 27	1250	827000 - 876000 - 1000000	5169 - 5309 - 5714
440	340 - 350 - 370	710	198	220	173	19	M 27	1250	1117000 - 1190000 - 1345000	6571 - 6800 - 7270
460	360 - 370 - 390	750	201	223	173	22	M 27	1250	1306000 - 1386000 - 1554000	7256 - 7492 - 7969
470	370 - 380 - 400	705	220	241,5	197	20	M 27	1250	950000 - 1000000 - 1150000	5135 - 5263 - 5750
480	380 - 390 - 410	770	223	247	198	22	M 30	1650	1557000 - 1648000 - 1818000	8195 - 8451 - 8868
500	400 - 410 - 430	820	217	241	195	19	M 30	1650	1653000 - 1725000 - 1915000	8265 - 8415 - 8907
530	430 - 440 - 460	850	238	262	213	22	M 30	1650	2048000 - 2154000 - 2374000	9526 - 9791 - 10322
560	450 - 460 - 480	885	242	266	217	22	M 30	1650	2306000 - 2419000 - 2654000	10249 - 10517 - 11058
590	470 - 480 - 500	950	257,5	281,5	232	21,5	M 30	1650	2735000 - 2863000 - 3128000	11638 - 11929 - 12512
620	500 - 520 - 540	960	283	307	254	25	M 30	1650	3150000 - 3396000 - 3689000	12600 - 13062 - 13663
660	530 - 550 - 570	1020	293	319	261	26	M 33	2250	3636000 - 3942000 - 4261000	13721 - 14335 - 14951
700	560 - 580 - 600	1085	292,5	318,5	257	29,5	M 33	2250	4189000 - 4520000 - 4863000	14961 - 15586 - 16210
750	600 - 620 - 650	1100	320	346	277	40	M 33	2250	5281000 - 5672000 - 6287000	17603 - 18297 - 19345
800	640 - 660 - 700	1230	333	359	290	37	M 33	2250	6091000 - 6511000 - 7394000	19034 - 19730 - 21126

T (Nm) = Coppia massima o forza assiale trasmissibile con coppia di serraggio viti Ts
 F (kN) = Pick torque or axial force transmissible with tightening torque Ts

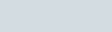
 = Chiave dinamometrica necessaria
 Need of a torque wrench

Ts (Nm) = Coppia di serraggio viti / Screws tightening torque

CONEX SB

d mm	ds mm	D mm	B mm	L mm	I mm	H mm	M mm	Ts Nm	T Nm	F kN
50	38 - 40 - 42	90	26	31,5	22	2,5	M 8	34	1600 - 1800 - 2000	84 - 90 - 95
55	42 - 45 - 48	100	29	34,5	24,5	3	M 8	34	1700 - 2100 - 2500	81 - 93 - 104
60	48 - 50 - 52	110	29	34,5	24,5	3	M 8	34	2300 - 2500 - 2900	96 - 100 - 112
62										
68	50 - 55 - 60	115	29,5	35	24,5	3,5	M 8	34	2400 - 3200 - 4000	96 - 116 - 133
75	55 - 60 - 65	138	31	37,5	25	4	M 10	70	3800 - 4900 - 6000	138 - 163 - 185
80	60 - 65 - 70	141	31	37,5	25	4	M 10	70	4300 - 5400 - 6500	143 - 166 - 186
85	65 - 70 - 75	155	38	44,5	31,5	4	M 10	70	6000 - 7200 - 8600	185 - 206 - 229
90										
95	70 - 75 - 80	170	43,5	50	36,5	4,5	M 10	70	7500 - 9000 - 10600	214 - 240 - 265
100										
105	80 - 85 - 90	185	49	56,5	40,5	5,5	M 12	120	12800 - 14800 - 17000	320 - 348 - 378
110										
115	85 - 90 - 95	197	53	60,5	45	5	M 12	120	13700 - 15800 - 18200	322 - 351 - 383
120										
125	90 - 95 - 100	215	53,5	61	45	5,5	M 12	120	16600 - 19000 - 21500	369 - 400 - 430
130	95 - 100 - 110	215	53,5	61	45	5,5	M 12	120	18300 - 21200 - 25000	385 - 424 - 455
130	95 - 100 - 110	230	57,5	66,5	47	6,5	M 14	190	20500 - 23500 - 29500	432 - 470 - 536
135										
140	100 - 105 - 115	230	58	67	47	7	M 14	190	23500 - 26000 - 32500	470 - 495 - 565
150	110 - 120 - 125	263	62	71	51	7,5	M 14	190	31500 - 35000 - 43000	573 - 583 - 688
155										
160	120 - 130 - 135	290	68,5	78,5	56	7,5	M 16	290	45000 - 49000 - 59000	750 - 754 - 874
165										
170	130 - 140 - 145	300	69	79	56	8	M 16	290	55000 - 60000 - 71000	846 - 857 - 979
175										
180	140 - 150 - 155	320	85	95	71,5	7,5	M 16	290	81000 - 88000 - 101000	1157 - 1173 - 1303
185										
190	150 - 160 - 165	340	88	98	71,5	10	M 16	290	97000 - 104000 - 120000	1293 - 1300 - 1455
195										
200	160 - 170 - 180	370	107,5	120	88	11	M 20	570	130000 - 150000 - 170000	1625 - 1765 - 1889
240	170 - 180 - 200	405	111	123,5	92	13	M 20	570	152000 - 174000 - 219000	1788 - 1933 - 2190
260	190 - 200 - 220	430	125,5	138	103	15	M 20	570	215000 - 240000 - 300000	2263 - 2400 - 2727
280	210 - 220 - 240	460	140	152,5	114	19	M 20	570	282000 - 313000 - 380000	2686 - 2845 - 3167
300	220 - 230 - 250	485	140	159	122	16	M 24	990	365000 - 403000 - 487000	3318 - 3504 - 3896
320	240 - 250 - 270	520	141,5	160,5	122	18	M 24	990	444000 - 488000 - 580000	3700 - 3904 - 4296
340	250 - 260 - 280	570	158,5	177,5	137	19	M 24	990	536000 - 586000 - 693000	4288 - 4508 - 4950
360	270 - 280 - 290	590	163	182	140	20	M 24	990	687000 - 744000 - 830000	5089 - 5314 - 5724
390	290 - 300 - 320	650	169	191	144	21	M 27	1480	859000 - 962000 - 1068000	5924 - 6413 - 6675
420	320 - 330 - 350	670	186	208	162	20	M 27	1480	1065000 - 1141000 - 1301000	6656 - 6915 - 7434
440	340 - 350 - 370	725	200	222	173	21	M 27	1480	1319000 - 1404000 - 1584000	7759 - 8023 - 8562
460	360 - 370 - 390	760	203	225	173	24	M 27	1480	1491000 - 1582000 - 1771000	8283 - 8551 - 9082
470	370 - 380 - 400	705	220	241,5	197	20	M 27	1480	1100000 - 1200000 - 1400000	5946 - 6316 - 7000
480	380 - 390 - 410	790	225	249	198	24	M 30	1980	1815000 - 1920000 - 2118000	9553 - 9846 - 10332
500	400 - 410 - 430	835	220	244	195	22	M 30	1980	2054000 - 2145000 - 2377000	10270 - 10463 - 11056
530	430 - 440 - 460	870	242,5	266,5	213	26,5	M 30	1980	2611000 - 2744000 - 3019000	12144 - 12473 - 13126
560	450 - 460 - 480	920	244,5	268,5	217	24,5	M 30	1980	2814000 - 2950000 - 3231000	12507 - 12826 - 13463
590	470 - 480 - 500	960	260	284	232	24	M 30	1980	3190000 - 3337000 - 3642000	13574 - 13904 - 14568
620	500 - 520 - 540	970	286	310	254	28	M 30	1980	3700000 - 3991000 - 4330000	14800 - 15350 - 16037
660	530 - 550 - 570	1050	296	322	261	29	M 33	2650	4395000 - 4760000 - 5139000	16585 - 17309 - 18032

Dati tecnici / Technical data

Tolleranze / Fit tolerance

d	H7 - f7
d _s ≤ ø160	H7 - h6
d _s > ø160	H7 - g6

La rugosità delle superfici di pressione dell'albero e del mozzo, debbono essere

$Ra \leq 3.2 \mu m$
(buona finitura al tornio)

Surface roughness on the pressure surfaces of the shaft and the hub should be

$Ra \leq 3.2 \mu m$
(good finishing on lathe)

CONEX SA - SB

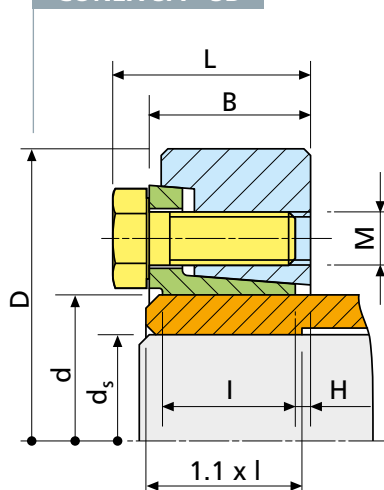

CONEX SF - SC

Applicazioni speciali per dischi freno, volani, corone dentate, leve, tamburi. Dati tecnici su richiesta.

Special applications for brake discs, flywheels, chainwheels, levers, drums. Technical data upon request.

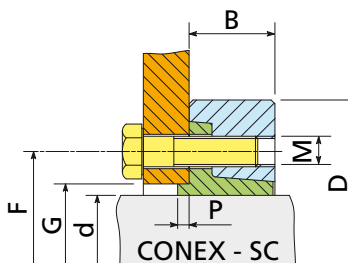
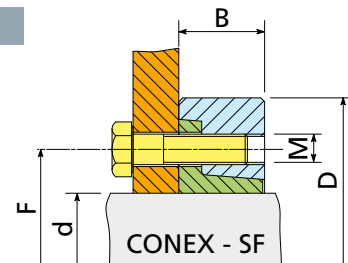

CONEX SAL - SBL

CONEX SAL

d mm	ds mm	D mm	B mm	L mm	I mm	H mm	M mm	Ts Nm	T Nm	F kN
185	140 - 145 - 155	320	112,5	125	97	9,5	M 20	480	101000 - 110000 - 127000	1443 - 1517 - 1639
200	150 - 155 - 165	340	111,5	124	93	12,5	M 20	480	108000 - 116000 - 134000	1440 - 1497 - 1624
220	160 - 165 - 180	370	132,5	145	116	10,5	M 20	480	138000 - 149000 - 183000	1725 - 1806 - 2033
240	170 - 180 - 200	405	142,2	154,7	123	13,2	M 20	480	173000 - 197000 - 248000	2035 - 2189 - 2480
260	190 - 200 - 220	430	163,8	176,3	143	14,8	M 20	480	249000 - 281000 - 347000	2621 - 2810 - 3155
280	210 - 220 - 240	460	172,2	191,2	151	14,2	M 24	840	331000 - 369000 - 448000	3152 - 3355 - 3733
300	230 - 240 - 250	485	175	194	153	16	M 24	840	382000 - 421000 - 461000	3322 - 3508 - 3688
320	240 - 250 - 270	520	184,6	203,6	160	18,6	M 24	840	445000 - 488000 - 574000	3708 - 3904 - 4252
340	250 - 260 - 280	570	204,6	226,6	180	18,6	M 27	1250	575000 - 627000 - 739000	4600 - 4823 - 5279
360	270 - 280 - 300	590	212,2	234,2	187	18,2	M 27	1250	681000 - 737000 - 863000	5044 - 5264 - 5753
390	290 - 300 - 320	650	220,5	242,5	194	20,5	M 27	1250	871000 - 935000 - 1075000	6007 - 6233 - 6719
420	320 - 330 - 350	670	246,4	268,4	217	23,4	M 27	1250	1052000 - 1126000 - 1281000	6575 - 6824 - 7320

CONEX SBL

d mm	ds mm	D mm	B mm	L mm	I mm	H mm	M mm	Ts Nm	T Nm	F kN
185	140 - 145 - 155	320	112,5	125	97	9,5	M 20	570	119000 - 130000 - 150000	1700 - 1793 - 1935
200	150 - 155 - 165	340	111,5	124	93	12,5	M 20	570	129000 - 139000 - 160000	1720 - 1794 - 1939
220	160 - 165 - 180	370	132,5	145	116	10,5	M 20	570	165000 - 178000 - 218000	2063 - 2158 - 2422
240	170 - 180 - 200	405	142,2	154,7	123	13,2	M 20	570	212000 - 241000 - 303000	2494 - 2678 - 3030
260	190 - 200 - 220	430	163,8	176,3	143	14,8	M 20	570	293000 - 331000 - 409000	3084 - 3310 - 3718
280	210 - 220 - 240	460	172,2	191,2	151	14,2	M 24	990	390000 - 435000 - 528000	3714 - 3955 - 4400
300	230 - 240 - 250	485	175	194	153	16	M 24	990	472000 - 520000 - 570000	4104 - 4333 - 4560
320	240 - 250 - 270	520	184,6	203,6	160	18,6	M 24	990	524000 - 575000 - 676000	4367 - 4600 - 5007
340	250 - 260 - 280	570	204,6	226,6	180	18,6	M 27	1480	677000 - 738000 - 870000	5416 - 5677 - 6214
360	270 - 280 - 300	590	212,2	234,2	187	18,2	M 27	1480	783000 - 848000 - 993000	5800 - 6057 - 6620
390	290 - 300 - 320	650	220,5	242,5	194	20,5	M 27	1480	1025000 - 1100000 - 1265000	7069 - 7333 - 7906
420	320 - 330 - 350	680	246,4	268,4	217	23,4	M 27	1480	1315000 - 1408000 - 1602000	8219 - 8533 - 9154

Dati tecnici / Technical data

Tolleranze / Fit tolerance

d	H7 - f7
$d_s \leq \varnothing 160$	H7 - h6
$d_s > \varnothing 160$	H7 - g6

La rugosità delle superfici di pressione dell'albero e del mozzo, debbono essere

$Ra \leq 3.2 \mu\text{m}$
(buona finitura al tornio)

Surface roughness on the pressure surfaces of the shaft and the hub should be

$Ra \leq 3.2 \mu\text{m}$
(good finishing on lathe)

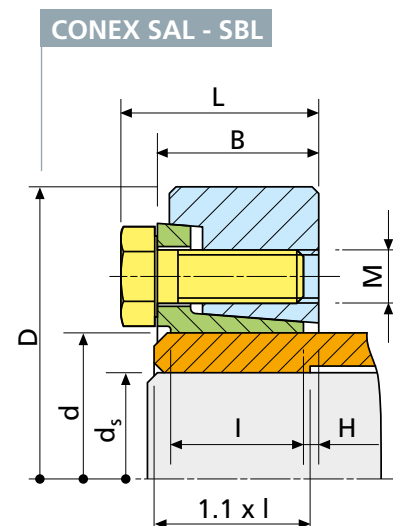

CONEX SD - Shrink Disc

(servizio normale / *standard duty*)

Blocco dall'esterno concentricità ottima

External clamping excellent concentricity

Tolleranze / Fit Tolerance

ds	ISO	gioco max max clearance
da / from	a / to	
10	18	0,014
18	30	0,017
30	50	0,032
50	80	0,048
80	120	0,069
120	180	0,079
180	250	0,090
250	315	0,101
315	400	0,111
400	500	0,123

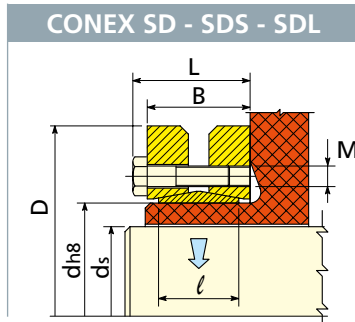

La rugosità delle superfici di pressione dell'albero e del mozzo, debbono essere $Ra \leq 3.2 \mu m$ (buona finitura al tornio)

Surface roughness on the pressure surfaces of the shaft and the hub should be $Ra \leq 3.2 \mu m$ (good finishing on lathe)

CONEX SD

d mm	ds mm	D mm	L mm	B mm	l mm	M mm	T _s Nm	T Nm	F kN
14	10 - 11 - 12	38	14,5	11	9	M 5	3,5	28 - 38 - 50	5 - 7 - 9
16	12 - 13 - 14	41	18,5	15	11	M 5	4	50 - 70 - 90	9 - 10 - 13
18	14 - 15 - 16	44	18,5	15	12	M 5	4	85 - 100 - 130	16 - 18 - 20
20	15 - 16 - 18	50	22,5	19	14	M 5	4	130 - 150 - 200	20 - 22 - 25
24	19 - 20 - 21	50	22,5	19	14	M 5	5	180 - 210 - 250	26 - 27 - 29
30	24 - 25 - 26	60	24,5	21	16	M 5	6	310 - 340 - 380	26 - 27 - 28
36	28 - 30 - 31	72	27	23	18	M 6	12	460 - 590 - 630	50 - 54 - 58
44	32 - 35 - 36	80	29	25	20	M 6	12	630 - 780 - 860	65 - 74 - 77
50	38 - 40 - 42	90	31	27	22	M 6	12	940 - 1100 - 1300	79 - 85 - 90
55	42 - 45 - 48	100	34	30	23	M 6	12	1200 - 1500 - 1900	80 - 90 - 100
62	48 - 50 - 52	110	34	30	23	M 6	12	1800 - 2200 - 2400	100 - 110 - 120
68	50 - 55 - 60	115	34	30	23	M 6	12	2000 - 2500 - 3100	100 - 110 - 120
75	55 - 60 - 65	138	37,5	32	25	M 8	30	2500 - 3200 - 3900	120 - 140 - 150
80	60 - 65 - 70	145	37,5	32	25	M 8	30	3200 - 3900 - 4600	120 - 140 - 160
85	65 - 70 - 75	155	44,5	39	30	M 8	30	4800 - 6100 - 7400	148 - 174 - 197
90	65 - 70 - 75	155	44,5	39	30	M 8	30	4700 - 6000 - 7200	170 - 190 - 210
100	70 - 75 - 80	170	49,5	44	34	M 8	30	6900 - 7500 - 9000	180 - 220 - 240
110	75 - 80 - 85	185	56,5	50	39	M 10	59	7200 - 9000 - 11000	230 - 250 - 260
115	80 - 85 - 90	188	56,5	50	39	M 10	59	8500 - 10000 - 12000	210 - 240 - 270
120	80 - 85 - 90	215	58,5	52	42	M 10	59	10500 - 13200 - 14400	280 - 300 - 330
125	85 - 90 - 95	215	58,5	52	42	M 10	59	11000 - 13000 - 15000	300 - 320 - 350
130	90 - 95 - 100	215	58,5	52	42	M 10	59	13700 - 15800 - 18200	300 - 330 - 360
140	95 - 100 - 105	230	67,5	60	46	M 12	100	15000 - 17000 - 20000	360 - 400 - 420
155	105 - 110 - 115	265	71,5	64	50	M 12	100	20000 - 23000 - 26000	390 - 420 - 450
160	110 - 115 - 120	265	71,5	64	50	M 12	100	22500 - 25500 - 28600	410 - 440 - 470
165	115 - 120 - 125	290	81	71	56	M 16	250	36000 - 39000 - 44000	630 - 660 - 700
170	120 - 125 - 130	290	81	71	56	M 16	250	31700 - 35800 - 40000	600 - 630 - 660
175	125 - 130 - 135	300	81	71	56	M 16	250	40000 - 44000 - 49000	650 - 680 - 720
180	130 - 135 - 140	300	81	71	56	M 16	250	36800 - 42000 - 46000	560 - 620 - 650
185	135 - 140 - 145	330	96	86	71	M 16	250	55000 - 60000 - 65000	815 - 875 - 896
190	140 - 145 - 150	330	96	86	71	M 16	250	53300 - 58500 - 63500	790 - 830 - 870
195	140 - 150 - 155	350	96	86	71	M 16	250	66000 - 76000 - 82000	950 - 1000 - 1100
200	150 - 155 - 160	350	96	86	71	M 16	250	73700 - 79800 - 85800	980 - 1000 - 1070
220	160 - 165 - 170	370	114	104	88	M 16	250	95000 - 102000 - 110000	1200 - 1300 - 1300
240	170 - 180 - 190	405	121,5	109	92	M 20	490	120000 - 140000 - 160000	1500 - 1600 - 1700
250	180 - 190 - 200	405	120,5	108	92	M 20	490	160000 - 180000 - 200000	1600 - 1700 - 1800
260	190 - 200 - 210	430	132,5	120	103	M 20	490	165000 - 185000 - 204000	1760 - 1878 - 2008
280	210 - 220 - 230	460	146,5	134	114	M 20	490	216000 - 245000 - 270000	2085 - 2220 - 2350
300	230 - 240 - 245	485	154,5	142	122	M 20	490	274000 - 296000 - 316000	2430 - 2560 - 2630
320	240 - 250 - 260	520	154,5	142	122	M 20	490	311000 - 340000 - 375000	2640 - 2780 - 2900
330	250 - 260 - 270	520	154,5	142	122	M 20	490	352000 - 385000 - 420000	2800 - 2900 - 3100
340	250 - 260 - 270	570	168,5	156	134	M 20	490	389000 - 422000 - 459000	3115 - 3245 - 3400
350	270 - 280 - 285	580	174,5	162	140	M 20	490	443000 - 480000 - 500000	3275 - 3430 - 3500
360	280 - 290 - 300	590	174,5	162	140	M 20	490	462000 - 500000 - 530000	3300 - 3460 - 3600
380	290 - 300 - 310	645	183	168	144	M 24	840	570000 - 610000 - 660000	3900 - 4070 - 4260
390	300 - 310 - 320	660	183	168	144	M 24	840	625000 - 670000 - 720000	4170 - 4325 - 4500
400	315 - 320 - 330	680	183	168	144	M 24	840	671000 - 695000 - 745000	4270 - 4340 - 4500
420	330 - 340 - 350	690	203	188	164	M 24	840	782000 - 841000 - 902000	4460 - 5000 - 5200
440	340 - 350 - 360	750	217	202	177	M 24	840	805000 - 861000 - 920000	4760 - 4930 - 5120
460	360 - 370 - 380	770	217	202	177	M 24	840	1000000 - 1073000 - 1141000	5560 - 5820 - 6020
480	380 - 390 - 400	800	228	213	188	M 24	840	1175000 - 1250000 - 1312000	6200 - 6450 - 6580
500	400 - 410 - 420	850	230	213	188	M 27	1250	1314000 - 1382000 - 1460000	6570 - 6740 - 7000

CONEX SDS - SDL

CONEX SDS (servizio leggero / light duty)

CONEX SDS

d mm	ds mm	D mm	L mm	B mm	ℓ mm	M mm	Ts Nm	T Nm	F kN
125	95 - 100 - 105	185	58	51	39	M 10	59	10700 - 12200 - 14000	223 - 242 - 263
140	110 - 120 - 125	220	58	51	39	M 10	59	15000 - 18900 - 20700	269 - 312 - 328
155	130 - 135 - 140	245	58	51	39	M 10	59	24200 - 26800 - 29300	369 - 393 - 414
165	135 - 140 - 145	260	70	62	46	M 12	100	32300 - 35600 - 38900	474 - 504 - 561
175	145 - 150 - 155	275	70	62	46	M 12	100	39400 - 43000 - 46500	538 - 567 - 594
185	155 - 160-165	295	70	62	46	M 12	100	47000 - 50900 - 54500	601 - 630 - 655
195	165 - 170 - 175	315	80	72	56	M 12	100	63600 - 68500 - 73200	764 - 799 - 829
200	175 - 180 - 185	330	80	72	56	M 12	100	74700 - 80800 - 85300	846 - 889 - 914
220	180 - 190- 200	345	94	84	66	M 16	250	83800 - 94400 - 106000	922 - 984 - 1050
240	200 - 210 - 215	370	94	84	66	M 16	250	114000 - 129000 - 136000	1130 - 1219 - 1256
260	220 - 230 - 235	395	102	92	72	M 16	250	150500 - 167500 - 175000	1355 - 1443 - 1472
280	230 - 240 - 250	425	114	104	84	M 16	250	173000 - 192000 - 210000	1487 - 1583 - 1664
300	250 - 260 - 270	460	114	104	84	M 16	250	217000 - 237500 - 257500	1720 - 1808 - 1889
320	270 - 280 - 290	495	116	106	84	M 16	250	262500 - 287000 - 309000	1926 - 2029 - 2110
340	290 - 300 - 305	535	116	106	84	M 16	250	303000 - 328000 - 340500	2069 - 2167 - 2210
350	300 - 305 - 310	545	135	122	100	M 20	490	375500 - 389000 - 404000	2480 - 2525 - 2581
360	300 - 310 - 320	555	135	122	100	M 20	490	363500 - 393000 - 419000	2400 - 2510 - 2594
380	320 - 325 - 330	585	149	136	112	M 20	490	439000 - 456000 - 472000	2719 - 2782 - 2836
390	330 - 340 - 350	595	149	136	112	M 20	490	510000 - 545000 - 583000	3061 - 3176 - 3297
400	340 - 350 - 360	615	149	136	112	M 20	490	555000 - 593000 - 632000	3235 - 3354 - 3478
420	350 - 360 - 370	630	157	144	120	M 20	490	584000 - 623000 - 662000	3303 - 3428 - 3546
440	370 - 380 - 390	660	157	144	120	M 20	490	684000 - 727000 - 769000	3659 - 3789 - 3908
460	390 - 400 - 410	685	171	158	132	M 20	490	848000 - 899000 - 944000	4308 - 4450 - 4561
480	410 - 420 - 425	715	171	158	132	M 20	490	900000 - 950000 - 975000	4346 - 4481 - 4546
500	425- 430 - 440	750	171	158	132	M 20	490	995000 - 1023000 - 1076000	4640 - 4712 - 4845

CONEX SDL (servizio pesante / heavy duty)

CONEX SDL

d mm	ds mm	D mm	L mm	B mm	ℓ mm	M mm	Ts Nm	T Nm	F kN
125	85 - 90 - 95	215	73	65	55	M 12	100	15000 - 17500 - 20000	355 - 388 - 422
140	95 - 100 - 110	230	82	74	60	M 12	100	20600 - 23500 - 26500	433 - 469 - 500
155	105 - 110 - 115	265	88	80	66	M 12	100	28600 - 32500 - 36400	550 - 590 - 630
165	115 - 120 - 125	290	98	88	72	M 16	250	41000 - 46000 - 50700	740 - 785 - 815
175	125 - 130 - 135	300	98	88	72	M 16	250	47000 - 52000 - 57000	750 - 795 - 540
185	135 - 140 - 145	330	122	112	92	M 16	250	73000 - 79000 - 87000	1100 - 1150 - 1200
195	140 - 150 - 155	350	122	112	92	M 16	250	76000 - 89000 - 97000	1075 - 1080 - 1235
200	150 - 155 - 160	350	122	112	92	M 16	250	93000 - 105000 - 115000	1240 - 1350 - 1435
220	160 - 165 - 170	370	144	134	114	M 16	250	128000 - 137000 - 147000	1590 - 1650 - 1720
240	170 - 180 - 190	405	156,5	144	120	M 20	490	157000 - 178000 - 199000	1820 - 1960 - 2080
260	190 - 200 - 210	430	172,5	160	136	M 20	490	215000 - 242000 - 269000	2260 - 2420 - 2580
280	210 - 220 - 230	460	184,5	172	148	M 20	490	286000 - 322000 - 356000	2740 - 2910 - 3090
300	230 - 240 - 250	485	188,5	176	152	M 20	490	342000 - 377000 - 402000	2960 - 3130 - 3215
320	240 - 250 - 260	520	196,5	184	160	M 20	490	379000 - 416000 - 452000	3150 - 3325 - 3470
340	250 - 260 - 270	570	215	200	176	M 24	840	490000 - 531000 - 579000	3910 - 4075 - 4275
350	270 - 280 - 290	580	215	200	176	M 24	840	557000 - 605000 - 630000	4122 - 4320 - 4415
360	280 - 290 - 300	590	219	204	180	M 24	840	613000 - 664000 - 701000	4370 - 4570 - 4670
380	290 - 300 - 310	645	219	204	180	M 24	840	619000 - 669000 - 720000	4270 - 4455 - 4645
390	300 - 310 - 320	660	227	212	188	M 24	840	709000 - 763000 - 815000	4715 - 4910 - 5090
400	310 - 320 - 330	680	227	212	188	M 24	840	752000 - 789000 - 846000	4855 - 4927 - 5125
420	330 - 340 - 350	690	253	238	214	M 24	840	1000000 - 1070000 - 1142000	6055 - 6285 - 6515
440	340 - 350 - 360	750	269	252	224	M 27	1250	1059000 - 1132000 - 1205000	6230 - 6460 - 6690
460	360 - 370 - 380	770	269	252	224	M 27	1250	1321000 - 1422000 - 1502000	7440 - 7700 - 7950
480	380 - 390 - 400	800	291	274	246	M 27	1250	1540000 - 1630000 - 1724000	8080 - 8340 - 8600
500	400 - 410 - 420	850	291	274	246	M 27	1250	1752000 - 1842000 - 1943000	8750 - 8980 - 9250

CONEX SD-SPLIT

(servizio normale / *standard duty*)

**Blocco dall'esterno
concentricità
ottima**

**External clamping
excellent
concentricity**



CONEX SD-SPLIT

La rugosità delle superfici di pressione dell'albero e del mozzo, debbono essere $Ra \leq 3.2 \mu m$ (buona finitura al tornio)

Surface roughness on the pressure surfaces of the shaft and the hub should be $Ra \leq 3.2 \mu m$ (good finishing on lathe)

CONEX SD-SPLIT-half TH / CONEX SD-SPLIT-half PH

La coppia trasmissibile è ridotta del 50%

The transmissible torque is reduced up to 50%

Tolleranze / Fit Tolerance

ds		ISO	gioco max max clearance
da / from	a / to		
18	30	H 6 / j 6	0,017
30	50	H 6 / h 6	0,032
50	80	H 6 / g 6	0,048
80	120	H 7 / g 6	0,069
120	180		0,079
180	250		0,090
250	315		0,101
315	400		0,111
400	500		0,123

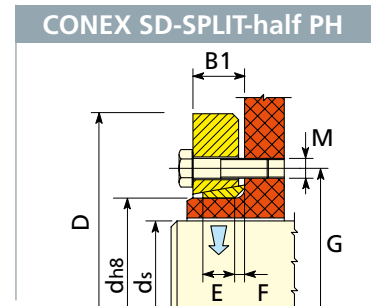
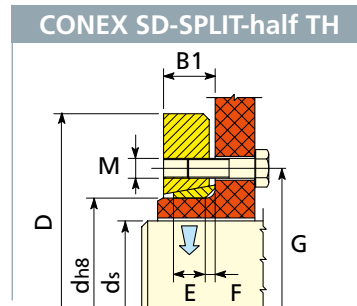
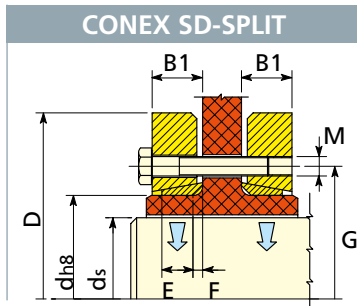

CONEX SD-SPLIT

d mm	ds mm	D mm	B1 mm	E mm	F mm	G mm	Viti n°	M mm	T _s Nm	T Nm	F kN
24	19 - 20 - 21	50	12	7	2,5	36	6	M 5	5	180 - 210 - 250	26 - 27 - 29
30	24 - 25 - 26	60	13	8	2,5	44	6	M 5	6	310 - 340 - 380	26 - 27 - 28
36	28 - 30 - 31	72	14	9	2,5	52	5	M 6	12	460 - 590 - 630	50 - 54 - 58
44	32 - 35 - 36	80	15	10	2,5	61	7	M 6	12	630 - 780 - 860	65 - 74 - 77
50	38 - 40 - 42	90	16	11	2,5	70	8	M 6	12	940 - 1100 - 1300	79 - 85 - 90
55	42 - 45 - 48	100	17,5	11,5	2,5	75	8	M 6	12	1200 - 1500 - 1900	80 - 90 - 100
62	48 - 50 - 52	110	17,5	11,5	2,5	86	10	M 6	12	1800 - 2200 - 2400	100 - 110 - 120
68	50 - 55 - 60	115	17,5	11,5	2,5	86	10	M 6	12	2000 - 2500 - 3100	100 - 110 - 120
75	55 - 60 - 65	138	21	12,5	5	100	7	M 8	30	2500 - 3200 - 3900	120 - 140 - 150
80	60 - 65 - 70	145	21	12,5	5	100	7	M 8	30	3200 - 3900 - 4600	120 - 140 - 160
85	65 - 70 - 75	155	24,5	15	5	114	10	M 8	30	4800 - 6100 - 7400	148 - 174 - 197
90	65 - 70 - 75	155	24,5	15	5	114	10	M 8	30	4700 - 6000 - 7200	170 - 190 - 210
100	70 - 75 - 80	170	27	17	5	124	12	M 8	30	6900 - 7500 - 9000	180 - 220 - 240
110	75 - 80 - 85	185	30	19,5	5	136	9	M 10	59	7200 - 9000 - 11000	230 - 250 - 260
125	85 - 90 - 95	215	31	21	5	160	12	M 10	59	11000 - 13000 - 15000	300 - 320 - 350
140	95 - 100 - 105	230	35	23	5	175	10	M 12	100	15000 - 17000 - 20000	360 - 400 - 420
155	105 - 110 - 115	265	37	25	5	192	12	M 12	100	20000 - 23000 - 26000	390 - 420 - 450
165	115 - 120 - 125	290	40,5	28	5	210	8	M 16	250	36000 - 39000 - 44000	630 - 660 - 700
175	125 - 130 - 135	300	40,5	28	5	220	8	M 16	250	40000 - 44000 - 49000	650 - 680 - 720
185	135 - 140 - 145	330	48	35,5	5	236	10	M 16	250	55000 - 60000 - 65000	815 - 875 - 896
195	140 - 150 - 155	350	48	35,5	5	246	12	M 16	250	66000 - 76000 - 82000	950 - 1000 - 1100
200	150 - 155 - 160	350	48	35,5	5	246	12	M 16	250	73700 - 79800 - 85800	980 - 1000 - 1070
220	160 - 165 - 170	370	59,5	44	7,5	270	15	M 16	250	95000 - 102000 - 110000	1200 - 1240 - 1300
240	170 - 180 - 190	405	62	46	7,5	295	12	M 20	490	120000 - 140000 - 160000	1500 - 1600 - 1700
260	190 - 200 - 210	430	67,5	51,5	7,5	321	14	M 20	490	165000 - 185000 - 205000	1760 - 1878 - 2008
280	210 - 220 - 230	460	76,5	57	8,5	346	16	M 20	490	216000 - 245000 - 270000	2085 - 2200 - 2350
300	230 - 240 - 250	485	79,5	61	8,5	364	18	M 20	490	274000 - 296000 - 316000	2430 - 2560 - 2630
320	240 - 250 - 260	520	79,5	61	8,5	386	20	M 20	490	310000 - 340000 - 375000	2640 - 2780 - 2900
340	250 - 260 - 270	570	86,5	67	8,5	408	24	M 20	490	390000 - 422000 - 459000	3115 - 3245 - 3400
350	270 - 280 - 285	580	89,5	70	8,5	432	24	M 20	490	443000 - 480000 - 500000	3275 - 3430 - 3500
360	280 - 290 - 300	590	89,5	70	8,5	432	24	M 20	490	462000 - 500000 - 530000	3300 - 3460 - 3600
380	290 - 300 - 310	645	92,5	72	8,5	458	20	M 24	840	570000 - 610000 - 660000	3900 - 4070 - 4260
390	300 - 310 - 320	660	92,5	72	8,5	468	21	M 24	840	625000 - 670000 - 720000	4170 - 4325 - 4500
400	315 - 320 - 330	680	92,5	72	8,5	480	21	M 24	840	671000 - 695000 - 745000	4270 - 4340 - 4500
420	340 - 350 - 360	690	106,5	84,5	10	504	24	M 24	840	782000 - 841000 - 902000	4460 - 5000 - 5200
440	340 - 350 - 360	750	113,5	91,5	10	527	24	M 24	840	805000 - 861000 - 920000	4760 - 4930 - 5120
460	360 - 370 - 380	770	113,5	91	10	547	28	M 24	840	1000000 - 1073000 - 1141000	5560 - 5820 - 6020
480	380 - 390 - 400	800	119	96,5	10	570	30	M 24	840	1175000 - 1250000 - 1312000	6200 - 6450 - 6580
500	400 - 410 - 420	850	119	96,5	10	590	24	M 27	1250	1314000 - 1382000 - 1460000	6570 - 6740 - 7000

CONEX B

**Autocentrante
Piccolo ingombro radiale**

*Self centering for
Thin walled hubs*



CONEX B

d mm	D mm	D ₁ mm	A mm	B mm	L mm	M mm	T _s Nm	T Nm	F kN	P N/mm ²
6	14	25	10	21,5	24,5	M 3	2,6	11	3,8	68
8	15	27	11,5	25	29	M 4	5,6	26	6,5	98
9	16	28	14	26	30	M 4	5,6	37	8	98
9,525	16	29	14	26	30	M 4	5,6	39	8	98
10	16	29	14	26	30	M 4	5,6	42	8	98
11	18	32	13,5	26	30	M 4	5,6	50	9	100
12	18	32	13,5	26	30	M 4	5,6	55	9	100
14	23	38	14	26	30	M 4	5,6	100	14	120
15	24	44	16	36	42	M 6	15	145	19	130
16	24	44	16	36	42	M 6	15	155	19	130
17	25	45	16	36	42	M 6	15	162	19	125
17	26	47	18	38	44	M 6	17	180	23	122
18	26	47	18	38	44	M 6	17	200	23	120
19	27	48	18	38	44	M 6	17	210	23	120
20	28	49	18	38	44	M 6	17	220	23	120
22	32	54	25	45	51	M 6	17	250	23	70
24	34	56	25	45	51	M 6	17	270	23	70
25	34	56	25	45	51	M 6	17	280	23	70
28	39	61	25	45	51	M 6	17	480	34	90
30	41	62	25	45	51	M 6	17	510	34	84
32	43	65	25	45	51	M 6	17	730	46	115
35	47	69	30	50	56	M 6	17	800	46	81
38	50	72	30	50	56	M 6	17	860	46	76
40	53	75	30	50	56	M 6	17	900	46	72
42	55	78	32	57	65	M 8	41	1800	84	125
45	59	85	40	65	73	M 8	41	1900	84	89
48	62	87	45	70	78	M 8	41	2000	84	75
50	65	92	45	70	78	M 8	41	2600	105	90
55	71	98	50	75	83	M 8	41	2900	105	70
60	77	104	50	75	83	M 8	41	3100	105	70

CONEX B

d mm	D mm	D ₁ mm	A mm	B mm	L mm	M mm	T _s Nm	T Nm	F kN	P N/mm ²
65	84	111	50	75	83	M 8	41	3400	105	60
70	90	119	60	91	101	M 10	83	5800	170	80
75	95	126	60	91	101	M 10	83	6200	170	70
80	100	131	65	96	106	M 10	83	8000	200	80
85	106	137	65	96	106	M 10	83	8500	200	70
90	112	143	65	96	106	M 10	83	11200	250	90
95	120	153	65	96	106	M 10	83	11800	250	80
100	125	162	65	102	114	M 12	145	14600	300	95
110	140	180	90	128	140	M 12	145	16000	300	61
120	155	198	90	128	140	M 12	145	17400	300	55
130	165	208	90	128	140	M 12	145	25000	389	69

I Conex B da d = 6 fino a d = 14 raggiungono le piene coppie trasmissibili solo lubrificando le superfici coniche e le viti con olii contenenti additivi per alte pressioni (M_oS₂).

Conex B from d = 6 up to d = 14 can transmit the full transmissible torque only oiling the conical surfaces and the screws with oils with high pressure additives (M_oS₂).

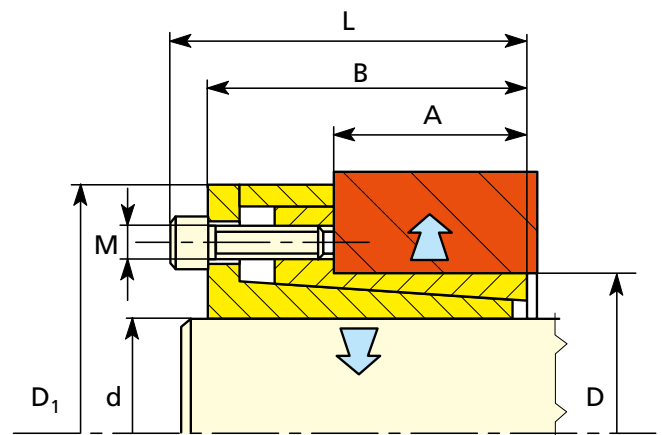

Non autocentrante. Piccolo ingombro radiale / Not self centering. Small radial dimensions

montaggio / mounting position **1**

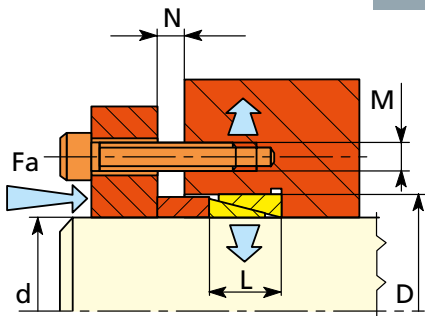

Durante il bloccaggio il mozzo può spostarsi assialmente. Smontaggio facile.
During the clamping the hub can axially displace. Easy removal.

montaggio / mounting position **2**

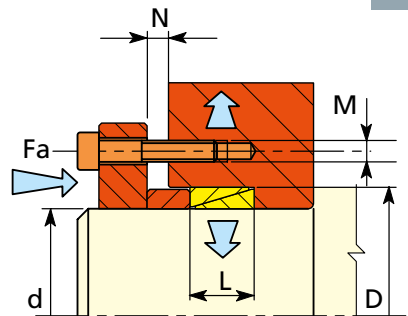

Durante il bloccaggio il mozzo rimane fisso assialmente.
During the clamping the hub remains axially fixed.



CONEX C

d mm	D mm	L mm	N				T Nm	F kN	P N/mm ²	F _A kN
			1	2	3	4				
6	9	4,5	3	3	3	4	2	0,8	75	3
7	10	4,5	3	3	3	4	4	1	84	5
8	11	4,5	3	3	3	4	5	1	90	6
9	12	4,5	3	3	3	4	8	1,6	95	16
10	13	4,5	3	3	3	4	10	2	100	16
12	15	4,5	3	3	3	4	11	2	90	15
13	16	4,5	3	3	3	4	13	2,1	105	16
14	18	6,3	3	4	4	5	22	3	90	26
15	19	6,3	3	4	4	5	25	3	90	26
16	20	6,3	3	4	4	5	26	3	90	25
17	21	6,3	3	4	4	5	30	3	90	26
18	22	6,3	3	4	4	5	33	3	90	26
19	24	6,3	3	4	4	5	40	4	90	32
20	25	6,3	3	4	4	5	44	4	90	32
22	26	6,3	3	4	4	5	50	4	90	30
24	28	6,3	3	4	4	5	68	6	100	34
25	30	6,3	3	4	4	5	75	6	100	37
28	32	6,3	3	4	4	5	90	6	100	37
30	35	6,3	3	4	4	5	100	7	100	39
32	36	6,3	3	4	4	5	120	7	100	42
35	40	7	3	4	4	5	160	9	100	55
36	42	7	4	5	5	6	170	9,5	100	58
38	44	7	4	5	5	6	190	10	100	60
40	45	8	4	5	5	6	230	11	100	67
42	48	8	4	5	5	6	260	12	100	73
45	52	10	4	5	5	6	390	17	100	106
48	55	10	4	5	5	6	430	18	100	107
50	57	10	4	5	5	6	470	19	100	110
55	62	10	4	5	5	6	580	21	100	119
56	64	12	4	5	5	6	740	24	100	151
60	68	12	4	5	6	7	840	28	100	156
63	71	12	4	5	6	7	920	29	100	160
65	73	12	4	5	6	7	1000	30	100	167
70	79	14	4	5	6	7	1300	38	100	202

CONEX C

d mm	D mm	L mm	N				T Nm	F kN	P N/mm ²	F _A kN
			1	2	3	4				
71	80	14	4	5	6	7	1400	39	100	212
75	84	14	4	5	6	7	1500	41	100	218
80	91	17	5	6	7	8	2100	54	100	289
85	96	17	5	6	7	8	2400	57	100	305
90	101	17	5	6	7	8	2700	61	100	319
95	106	17	5	6	8	9	3000	64	100	331
100	114	21	5	6	8	9	4200	84	100	447
110	124	21	5	6	8	9	4700	86	90	458
120	134	21	5	6	8	9	5100	88	90	451
130	148	28	6	7	9	11	8100	125	90	669
140	158	28	6	7	9	11	9400	135	90	707
150	168	28	6	7	9	11	11000	145	90	758
160	178	28	6	7	9	11	14500	180	105	912
170	191	33	7	8	10	12	19500	228	105	1172
180	201	33	7	8	10	12	21200	235	105	1194
190	211	33	7	9	10	12	24100	250	110	1272
200	224	38	7	9	11	13	31000	310	105	1558
210	234	38	7	9	11	13	35000	332	109	1659
220	244	38	7	9	11	13	38000	344	108	1709
240	267	43	7	9	12	14	47000	391	99	1959
250	280	48	8	10	13	16	52000	415	90	2100
260	290	48	8	10	13	16	56500	435	90	2178
280	313	53	9	11	14	17	72500	518	90	2586
300	333	53	9	11	14	17	83000	553	90	2758
320	360	65	10	15	20	25	114000	719	89	3566
340	380	65	10	15	20	25	128500	778	89	3749
360	400	65	10	15	20	25	144000	800	87	3938
380	420	65	10	15	20	25	160000	845	90	4139
400	440	65	10	15	20	25	178000	890	91	4347
420	460	65	10	15	20	25	196000	933	91	4534
440	480	65	10	15	20	25	215000	977	92	4726

Montaggi in serie di più unità
Assembly in series of more units

2 Conex C T₂ = T x 1,6
3 Conex C T₃ = T x 1,9
4 Conex C T₄ = T x 2,1

F_A Forza di precarico: è data dal numero di viti sulla flangia, strette alla coppia T_s.
Ogni vite produce la forza F_s e il numero di viti sarà n • F_s = F_A.
Applicando la forza di precarico F_A, è possibile trasmettere la coppia T o lo sforzo assiale F.

F_A Preload force. It is produced by the nr. of screws on the flange, tightened with the torque T_s.
Every screw produces the force F_s and the number of screws should be: n • F_s = F_A.
The preload force F_A generates the transmissible torque T or axial force F.

Viti tipo Screw size	T _s Nm	F _s kN
M 6	10	9
M 8	26	16
M 10	49	26
M 12	85	38
M 14	135	52

d = 6, 7, 8 i dati tecnici sono riferiti ai tipi con taglio / the technical data refers to the slitted types

CONEX DS (short) - CONEX ES (short)

CONEX DS - CONEX ES							CONEX DS				CONEX ES			
d	D	D ₁	A	B	L	M	T _s	T	F	P	T _s	T	F	P
mm	mm	mm	mm	mm	mm	mm	Nm	Nm	kN	N/mm ²	Nm	Nm	kN	N/mm ²
18	47	53	22	28	34	M 6	14	370	41	140	17	290	32	100
19	47	53	22	28	34	M 6	14	390	41	140	17	300	32	100
20	47	53	22	28	34	M 6	14	410	41	140	17	320	32	100
22	47	53	22	28	34	M 6	14	450	41	140	17	350	32	100
24	50	56	22	28	34	M 6	14	490	41	130	17	390	32	100
25	50	56	22	28	34	M 6	14	510	41	130	17	400	32	100
28	55	61,4	22	28	34	M 6	14	570	41	120	17	450	32	90
30	55	61,4	22	28	34	M 6	14	610	41	120	17	490	32	90
32	60	67	22	28	34	M 6	14	880	55	145	17	700	43	110
35	60	67	22	28	34	M 6	14	960	55	145	17	760	43	110
38	65	72	22	28	34	M 6	14	1000	55	135	17	820	43	100
40	65	72	22	28	34	M 6	14	1100	55	135	17	870	43	100
42	75	84	25	33	41	M 8	35	2200	105	190	41	1700	80	140
45	75	84	25	33	41	M 8	35	2400	105	190	41	1800	80	140
48	80	89	24	33,5	41	M 8	35	2500	105	175	41	1900	80	130
50	80	89	24	33,5	41	M 8	35	2600	105	175	41	2000	80	130
55	85	94	24	33,5	41	M 8	35	2900	105	165	41	2200	80	120
60	90	99	24	33,5	41	M 8	35	3100	105	155	41	2400	80	120
65	95	104	24	33,5	41	M 8	35	3400	105	150	41	2600	80	110
70	110	119	29	40	50	M 10	70	6000	170	175	83	4600	130	130
75	115	124	29	40	50	M 10	70	6400	170	170	83	5000	130	130
80	120	129	29	40	50	M 10	70	6800	170	160	83	5300	130	120
85	125	134	29	40	50	M 10	70	9000	210	190	83	7000	160	150
90	130	139	29	40	50	M 10	70	9600	210	185	83	7400	160	140
95	135	144	29	40	50	M 10	70	10200	210	185	83	7800	160	130
100	145	154	31	44	56	M 12	115	12000	235	170	145	9700	200	140
110	155	164	31	44	56	M 12	115	13000	260	160	145	10700	200	130
120	165	174	31	44	56	M 12	115	16000	270	165	145	13100	220	150
130	180	189	39	52	64	M 12	115	23000	350	155	145	19000	290	130
140	190	199	39	54	68	M 14	185	25000	360	150	230	20500	300	140
150	200	209	39	54	68	M 14	185	30000	400	155	230	24500	330	130
160	210	219	39	54	68	M 14	185	38800	480	170	230	31300	390	150
170	225	234	49	64	78	M 14	185	41300	480	130	230	33200	390	110
180	235	244	49	64	78	M 14	185	43700	480	125	230	35000	390	100
190	250	259	49	64	78	M 14	185	57700	600	145	230	46500	500	120
200	260	269	49	64	78	M 14	185	60700	600	140	230	49000	500	110
220	285	294	57	72	88	M 16	290	78100	710	132	360	57100	519	97
240	305	314	57	72	88	M 16	290	106500	848	154	360	77800	649	113
260	325	334	57	72	88	M 16	290	138500	1017	174	360	101200	778	127
280	355	364	66	84	102	M 18	400	160300	1094	143	480	113300	808	101
300	375	384	66	84	102	M 18	400	193200	1230	152	480	136500	910	107
320	405	414	81	101	121	M 20	580	272700	1627	151	690	191000	1193	106
340	425	434	81	101	121	M 20	580	338000	1899	168	690	237000	1393	118
360	455	464	93	116	138	M 22	780	375700	1994	142	930	264000	1465	99
380	475	484	93	116	138	M 22	780	462700	2326	158	930	325000	1709	111
400	495	504	93	116	138	M 22	780	487000	2326	152	930	342000	1709	107

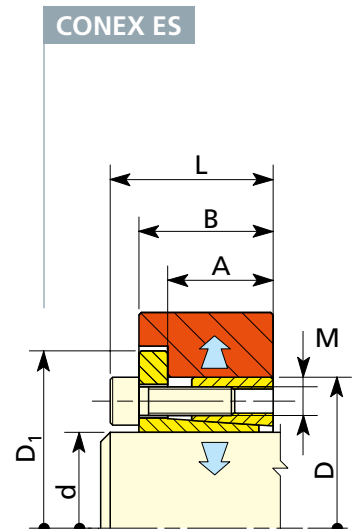
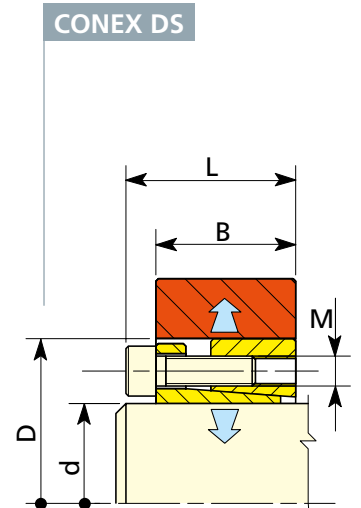

CONEX DS	CONEX ES	
<p>Autocentrante - coppie trasmissibili alte. Durante il bloccaggio il mozzo può spostarsi assialmente.</p> <p><i>Self centering - high transmissible torque.</i> <i>During the clamping the hub can axially displace.</i></p>	<p>Autocentrante. Durante il bloccaggio il mozzo rimane fisso assialmente.</p> <p><i>Self centering.</i> <i>During the clamping the hub remains axially fixed.</i></p>	

CONEX DS CONEX ES (pollici/ inch)	CONEX DS - CONEX ES							CONEX -DS				CONEX -ES			
	d inch	D inch	D1 inch	A inch	B inch	L inch	M mm	Ts ft-lb	T ft.lb	F lbs	P psi	Ts ft-lb	T ft.lb	F lbs	P psi
3/4	0,7500	1,850	2,087	0,866	1,102	1,339	M 6	10	289	9243	19810	13	227	7261	15553
7/8	0,8750	1,850	2,087	0,866	1,102	1,339	M 6	10	337	9243	19810	13	265	7261	15553
1	1,0000	1,969	2,205	0,866	1,102	1,339	M 6	10	385	9243	18613	13	303	7261	14620
1 1/8	1,1250	2,165	2,417	0,866	1,102	1,339	M 6	10	433	9243	16928	13	341	7261	13291
1 3/16	1,1875	2,165	2,417	0,866	1,102	1,339	M 6	10	457	9243	16928	13	359	7261	13291
1 1/4	1,2500	2,362	2,638	0,866	1,102	1,339	M 6	10	642	12324	20688	13	504	9682	16245
1 3/8	1,3750	2,362	2,638	0,866	1,102	1,339	M 6	10	706	12324	20688	13	555	9682	16245
1 7/16	1,4375	2,559	2,835	0,866	1,102	1,339	M 6	10	738	12324	19095	13	580	9682	14995
1 1/2	1,5000	2,559	2,835	0,866	1,102	1,339	M 6	10	770	12324	19095	13	605	9682	14995
1 5/8	1,6250	2,953	3,307	0,984	1,299	1,614	M 8	26	1600	23631	26973	30	1213	17909	20433
1 11/16	1,6875	2,953	3,307	0,984	1,299	1,614	M 8	26	1662	23631	26973	30	1259	17909	20433
1 3/4	1,7500	2,953	3,307	0,984	1,299	1,614	M 8	26	1723	23631	26973	30	1306	17909	20433
1 7/8	1,8750	3,150	3,504	0,945	1,319	1,634	M 8	26	1846	23631	25286	30	1399	17909	19156
1 15/16	1,9375	3,150	3,504	0,945	1,319	1,634	M 8	26	1908	23631	25286	30	1446	17909	19156
2	2,0000	3,150	3,504	0,945	1,319	1,634	M 8	26	1970	23631	25286	30	1492	17909	19156
2 1/8	2,1250	3,346	3,701	0,945	1,319	1,634	M 8	26	2092	23631	23805	30	1586	17909	18029
2 3/16	2,1875	3,346	3,701	0,945	1,319	1,634	M 8	26	2154	23631	23805	30	1633	17909	18029
2 1/4	2,2500	3,543	3,898	0,945	1,319	1,634	M 8	26	2215	23631	22481	30	1679	17909	17028
2 3/8	2,3750	3,543	3,898	0,945	1,319	1,634	M 8	26	2339	23631	22481	30	1772	17909	17028
2 7/16	2,4375	3,740	4,094	0,945	1,319	1,634	M 8	26	2400	23631	21297	30	1819	17909	16132
2 1/2	2,5000	3,740	4,094	0,945	1,319	1,634	M 8	26	2461	23631	21297	30	1865	17909	16132
2 9/16	2,5625	3,740	4,094	0,945	1,319	1,634	M 8	26	2523	23631	21297	30	1912	17909	16132
2 11/16	2,6875	4,331	4,685	1,142	1,575	1,969	M 10	52	4312	38506	24957	61	3308	29538	19148
2 3/4	2,7500	4,331	4,685	1,142	1,575	1,969	M 10	52	4412	38506	24957	61	3384	29538	19148
2 7/8	2,8750	4,528	4,882	1,142	1,575	1,969	M 10	52	4613	38506	23871	61	3538	29538	18316
2 15/16	2,9375	4,528	4,882	1,142	1,575	1,969	M 10	52	4713	38506	23871	61	3616	29538	18316
3	3,0000	4,724	5,079	1,142	1,575	1,969	M 10	52	4813	38506	22880	61	3693	29538	17553
3 1/4	3,2500	4,921	5,276	1,142	1,575	1,969	M 10	52	6518	48132	27456	61	4000	29538	16850
3 3/8	3,3750	4,921	5,276	1,142	1,575	1,969	M 10	52	6769	48132	27456	61	5192	36923	21063
3 7/16	3,4375	5,118	5,472	1,142	1,575	1,969	M 10	52	6894	48132	26399	61	5289	36923	20253
3 1/2	3,5000	5,118	5,472	1,142	1,575	1,969	M 10	52	7019	48132	26399	61	5385	36923	20253
3 3/4	3,7500	5,315	5,669	1,142	1,575	1,969	M 10	52	7521	48132	25420	61	5769	36923	19503
3 15/16	3,9375	5,709	6,063	1,260	1,732	2,205	M 12	85	8779	53511	24281	107	7162	43651	19815
4	4,0000	5,709	6,063	1,260	1,732	2,205	M 12	85	8918	53511	24281	107	7275	43651	19815

CONEX D - CONEX E

CONEX D	CONEX E
<p>Autocentrante - coppie trasmissibili alte. Durante il bloccaggio il mozzo può spostarsi assialmente.</p> <p>Self centering - high transmissible torque. During the clamping the hub can axially displace.</p>	<p>Autocentrante. Durante il bloccaggio il mozzo rimane fisso assialmente.</p> <p>Self centering. During the clamping the hub remains axially fixed.</p>

CONEX D - CONEX E							CONEX D				CONEX E			
d mm	D mm	D ₁ mm	A mm	B mm	L mm	M mm	T _s Nm	T Nm	F kN	P N/mm ²	T _s Nm	T Nm	F kN	P N/mm ²
20	47	53	31	42	48	M 6	17	530	52	110	17	320	33	70
22	47	53	31	42	48	M 6	17	580	52	110	17	360	33	70
24	50	56	31	42	48	M 6	17	630	52	100	17	390	33	70
25	50	56	31	42	48	M 6	17	660	52	100	17	400	33	70
28	55	61	31	42	48	M 6	17	740	52	100	17	450	33	60
30	55	61	31	42	48	M 6	17	790	52	100	17	490	33	60
32	60	66	31	42	48	M 6	17	1150	70	120	17	690	43	70
35	60	66	31	42	48	M 6	17	1300	70	120	17	750	43	70
38	65	71	31	42	48	M 6	17	1300	70	110	17	820	43	70
40	65	71	31	42	48	M 6	17	1400	70	110	17	860	43	70
42	75	81	35	51	59	M 8	41	2000	100	120	41	1300	60	70
45	75	81	35	51	59	M 8	41	2200	100	120	41	1400	60	70
48	80	86	35	51	59	M 8	41	3200	130	150	41	1900	80	90
50	80	86	35	51	59	M 8	41	3300	130	150	41	2000	80	90
55	85	91	35	51	59	M 8	41	3600	130	140	41	2200	80	90
60	90	96	35	51	59	M 8	41	3900	130	130	41	2400	80	80
65	95	101	35	51	59	M 8	41	4300	130	120	41	2600	80	70
70	110	119	46	61	71	M 10	83	7500	210	130	83	4600	130	80
75	115	124	46	61	71	M 10	83	8000	210	130	83	5000	130	80
80	120	129	46	61	71	M 10	83	8500	210	120	83	5200	130	70
85	125	134	46	61	71	M 10	83	11400	270	150	83	7000	170	90
90	130	139	46	61	71	M 10	83	12000	270	140	83	7400	170	80
95	135	144	46	61	71	M 10	83	12600	280	135	83	7800	170	80
100	145	155	52	68	80	M 12	145	15000	300	130	145	9800	190	80
110	155	165	52	68	80	M 12	145	16500	300	120	145	10700	190	70
120	165	175	52	68	80	M 12	145	22500	370	140	145	14600	240	90
130	180	188	52	68	80	M 12	145	29000	450	150	145	19000	300	100
140	190	199	58	76	90	M 14	210	32000	460	130	230	23000	330	90
150	200	209	58	76	90	M 14	210	41000	550	150	230	30000	400	100
160	210	219	58	76	90	M 14	210	44000	550	140	230	32000	400	100
170	225	234	58	76	90	M 14	210	54500	640	160	230	39000	460	110
180	235	244	58	76	90	M 14	210	57500	640	150	230	41000	460	100
190	250	259	58	76	90	M 14	210	65000	689	146	230	46400	488	104
200	260	269	58	76	90	M 14	210	68000	689	141	230	48800	488	100
220	285	294	72	98	114	M 16	325	82000	747	109	360	59900	544	79

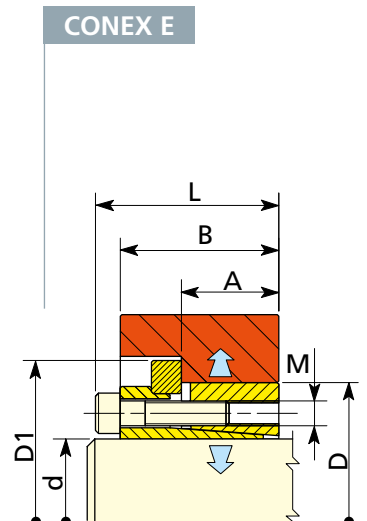
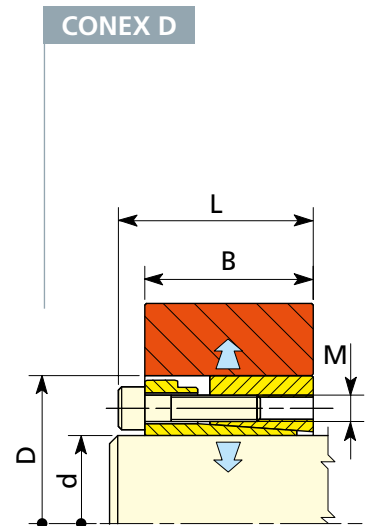

CONEX FS

**Autocentrante -
coppie molto alte**

**Self centering -
very high torque**

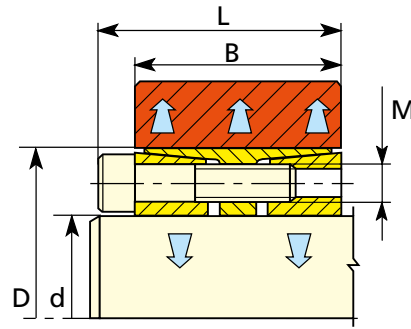

CONEX FS

					Coppie alte - Servizio pesante <i>High Torque - Heavy Duty</i>				Pressioni basse* - Servizio leggero <i>Low Pressures* - Light Duty</i>			
d mm	D mm	M mm	B mm	L mm	T _s Nm	T Nm	F kN	P N/mm ²	T _s Nm	T Nm	F kN	P N/mm ²
70	110	M10	62	72	83	7270	208	125	49	4250	121	74
75	115	M10	62	72	83	7780	207	120	49	4590	122	71
80	120	M10	62	72	83	10350	259	143	49	6100	153	85
85	125	M10	62	72	83	11000	259	138	49	6500	153	81
90	130	M10	62	72	83	12800	284	146	49	7580	168	86
95	135	M10	62	72	83	13500	284	140	49	8000	168	83
100	145	M12	72	84	145	19400	388	148	69	9200	184	71
110	155	M12	72	84	145	21400	389	139	69	10100	184	66
120	165	M12	72	84	145	25600	427	144	69	12200	203	68
130	180	M12	82	94	145	35400	545	149	69	16800	258	71
140	190	M12	82	94	145	40800	583	151	69	19400	277	72
150	200	M12	82	94	145	43700	583	144	69	20800	277	68
160	210	M12	82	94	145	49800	623	145	69	23700	296	69
170	225	M14	93	107	230	67500	794	146	108	31700	373	69
180	235	M14	93	107	230	71500	794	140	108	33500	372	66
190	250	M14	105	119	230	80500	847	118	108	37800	398	56
200	260	M14	105	119	230	95000	950	128	108	44700	447	60
220	285	M16	111	127	355	119000	1082	124	168	56500	514	59
240	305	M16	111	127	355	173500	1446	154	168	82200	685	72
260	325	M16	111	127	355	197500	1519	152	168	93500	719	71
280	355	M20	111	131	690	236000	1686	166	369	126000	900	89
300	375	M20	111	131	690	270000	1800	168	369	144000	960	90
320	405	M20	136	156	690	360000	2250	154	369	192000	1200	82
340	425	M20	136	156	690	382000	2247	147	369	204000	1200	78
360	455	M22	155	177	930	501000	2783	142	550	296000	1644	84
380	475	M22	155	177	930	529000	2784	135	550	313000	1647	80
400	495	M22	155	177	930	613000	3065	143	550	362000	1810	85
420	515	M22	155	177	930	702000	3343	150	550	415000	1976	88
440	535	M22	155	177	930	735000	3341	144	550	435000	1977	86
460	555	M22	155	177	930	769000	3343	139	550	454000	1974	82
480	575	M22	155	177	930	835000	3479	140	550	494000	2058	83
500	595	M22	155	177	930	870000	3480	135	550	514000	2056	80
520	615	M22	155	177	930	1014000	3900	146	550	599000	2304	86
540	635	M22	155	177	930	1053000	3900	136	550	622000	2304	80
560	655	M22	155	177	930	1170000	4179	141	550	692000	2471	84
580	675	M22	155	177	930	1210000	4172	137	550	716000	2469	81
600	695	M22	155	177	930	1250000	4167	139	550	741000	2470	78

* Adatti per mozzi a parete sottile, per esempio tamburi per trasportatori
Suitable for thin wall hubs, like for example conveyors' drums assembly

CONEX F - CONEX G - CONEX FL

CONEX F - CONEX G CONEX FL

**Autocentrante -
coppie molto alte**

**Self centering -
very high torque**

CONEX F

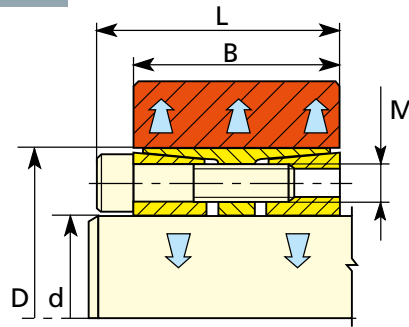

CONEX G

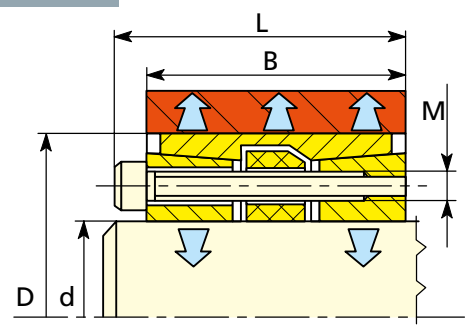

CONEX F

d mm	D mm	M mm	B mm	L mm	T _s Nm	T Nm	F kN	P N/mm ²
25	50	M 6	45	51	17	730	60	92
28	55	M 6	45	51	17	1100	80	112
30	55	M 6	45	51	17	1180	80	112
32	60	M 6	45	51	17	1270	80	100
35	60	M 6	45	51	17	1390	80	100
38	65	M 6	45	51	17	1880	100	115
40	65	M 6	45	51	17	1980	100	115
42	75	M 8	45	51	41	3000	145	145
45	75	M 8	45	51	41	3250	145	145
48	80	M 8	62	70	41	3450	145	95
50	80	M 8	62	70	41	3600	145	95
55	85	M 8	62	70	41	3950	145	90
60	90	M 8	62	70	41	5400	180	107
65	95	M 8	62	70	41	5850	180	100
70	110	M 10	76	86	83	10200	290	115
75	115	M 10	76	86	83	10950	290	110
80	120	M 10	76	86	83	14000	350	128
85	125	M 10	76	86	83	15000	350	123
90	130	M 10	76	86	83	15800	350	118
95	135	M 10	76	86	83	16800	350	115
100	145	M 12	98	110	145	26000	520	120
110	155	M 12	98	110	145	28600	520	110
120	165	M 12	98	110	145	36300	605	122
130	180	M 14	114	128	230	46000	710	112
140	190	M 14	114	128	230	57800	825	123
150	200	M 14	114	128	230	70800	945	135
160	210	M 14	114	128	230	75500	945	128
170	225	M 16	146	162	355	95900	1130	113
180	235	M 16	146	162	355	108800	1210	115
190	250	M 16	146	162	355	122500	1290	115
200	260	M 16	146	162	355	128900	1290	110
220	285	M 16	146	162	355	171800	1565	115
240	305	M 16	146	162	355	208000	1735	120
260	325	M 16	150	166	355	237000	1825	117
280	355	M 20	177	197	690	340000	2430	120
300	375	M 20	177	197	690	405000	2700	125
320	405	M 20	177	197	690	453000	2835	122
340	425	M 20	177	197	690	504900	2970	122
360	455	M 22	202	224	930	626000	3480	115
380	475	M 22	202	224	930	692000	3645	115
400	495	M 22	202	224	930	795000	3980	120
420	515	M 22	202	224	930	835000	3980	115
440	535	M 22	202	224	930	875000	3980	110
460	555	M 22	202	224	930	914000	3980	107
480	575	M 22	202	224	930	1113000	4640	120

CONEX F

d mm	D mm	M mm	B mm	L mm	T _s Nm	T Nm	F kN	P N/mm ²
500	595	M 22	202	224	930	1160000	4640	115
520	615	M 22	202	224	930	1292000	4970	120
540	635	M 22	202	224	930	1342000	4970	115
560	655	M 22	202	224	930	1484000	5300	120
580	675	M 22	202	224	930	1537000	5300	117
600	695	M 22	202	224	930	1640000	5470	117

A partire da d 400, anello esterno non tagliato
Starting from d 400, outer ring not slitted

CONEX G

d mm	D mm	M mm	B mm	L mm	T _s Nm	T Nm	F kN	P N/mm ²
50	80	M 8	78	86	41	3600	145	65
60	90	M 8	78	86	41	5400	180	75
70	110	M 10	102	112	83	10200	290	75
80	120	M 10	102	112	83	14000	350	85
90	130	M 10	102	112	83	15800	350	75
100	145	M 12	122	134	145	26000	520	80

CONEX FL

d mm	D mm	M mm	B mm	L mm	T _s Nm	T Nm	F kN	P N/mm ²
180	285	M 22	229	251	930	224000	2489	129
200	305	M 22	229	251	930	285000	2850	137
220	325	M 22	229	251	930	313000	2845	129
240	355	M 24	238	262	1200	394000	3283	125
260	375	M 24	238	262	1200	481000	3700	133
280	405	M 24	238	262	1200	575000	4107	137
300	425	M 24	238	262	1200	616000	4107	130
320	455	M 27	280	307	1750	776000	4850	120
340	475	M 27	280	307	1750	920000	5412	128
360	495	M 27	280	307	1750	1070000	5944	135
380	515	M 27	280	307	1750	1130000	5947	130
400	535	M 27	280	307	1750	1190000	5950	125
420	555	M 27	280	307	1750	1360000	6476	130
440	575	M 27	280	307	1750	1430000	6500	127
460	595	M 27	280	307	1750	1490000	6478	123
480	615	M 27	280	307	1750	1820000	7583	138
500	635	M 27	280	307	1750	1890000	7560	134
520	655	M 27	280	307	1750	1970000	7577	130
540	675	M 27	280	307	1750	2190000	8111	135
560	695	M 27	280	307	1750	2270000	8107	130

A partire da d 420, anello esterno non tagliato
Starting from d 420, outer ring not slitted

CONEX FL

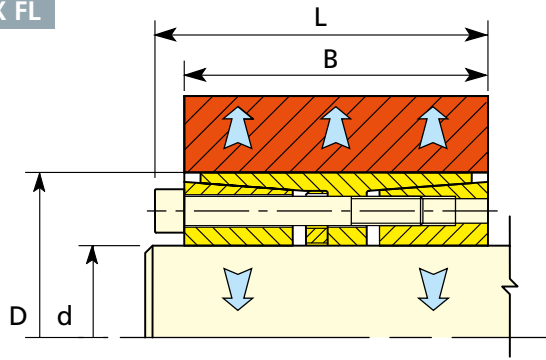

CONEX F (pollici/inch)	d inch	D inch	B inch	L inch	M mm	T_s ft-lb	T ft-lb	F lbs	P psi
1	1,000	2,165	1,772	2,008	M 6	12	557	13368	10682
1 1/8	1,125	2,165	1,772	2,008	M 6	12	627	13368	10682
1 3/16	1,188	2,165	1,772	2,008	M 6	12	882	17824	14243
1 1/4	1,250	2,362	1,772	2,008	M 6	12	928	17824	13055
1 3/8	1,375	2,362	1,772	2,008	M 6	12	1021	17824	13055
1 7/16	1,438	2,362	1,772	2,008	M 6	12	1068	17824	13055
1 1/2	1,500	2,559	1,772	2,008	M 6	12	1393	22280	15062
1 5/8	1,625	2,559	1,772	2,008	M 6	12	1509	22280	15062
1 11/16	1,688	2,953	1,772	2,087	M 8	30	2359	33546	19653
1 3/4	1,750	2,953	1,772	2,087	M 8	30	2446	33546	19653
1 7/8	1,875	3,150	2,520	2,835	M 8	30	2621	33546	13486
1 15/16	1,938	3,150	2,520	2,835	M 8	30	2708	33546	13486
2	2,000	3,150	2,520	2,835	M 8	30	2796	33546	13486
2 1/8	2,125	3,346	2,520	2,835	M 8	30	2970	33546	12696
2 3/16	2,188	3,346	2,520	2,835	M 8	30	3058	33546	12696
2 1/4	2,250	3,543	2,520	2,835	M 8	30	3931	41933	14987
2 3/8	2,375	3,543	2,520	2,835	M 8	30	4150	41933	14987
2 7/16	2,438	3,740	2,520	2,835	M 8	30	4259	41933	14198
2 1/2	2,500	3,740	2,520	2,835	M 8	30	4368	41933	14198
2 9/16	2,563	3,740	2,520	2,835	M 8	30	4477	41933	14198
2 5/8	2,625	4,331	3,071	3,465	M 10	60	7348	67180	15715
2 11/16	2,688	4,331	3,071	3,465	M 10	60	7523	67180	15715
2 3/4	2,750	4,331	3,071	3,465	M 10	60	7698	67180	15715
2 7/8	2,875	4,331	3,071	3,465	M 10	60	8048	67180	15715
2 15/16	2,938	4,724	3,071	3,465	M 10	60	9867	80616	17289
3	3,000	4,724	3,071	3,465	M 10	60	10077	80616	17289
3 1/8	3,125	4,724	3,071	3,465	M 10	60	10497	80616	17289
3 1/4	3,250	4,724	3,071	3,465	M 10	60	10917	80616	17289
3 3/8	3,375	5,118	3,071	3,465	M 10	60	11337	80616	15958
3 7/16	3,438	5,118	3,071	3,465	M 10	60	11547	80616	15958
3 1/2	3,500	5,118	3,071	3,465	M 10	60	11756	80616	15958
3 5/8	3,625	5,118	3,071	3,465	M 10	60	12176	80616	15958
3 3/4	3,750	5,709	3,937	4,409	M 12	105	18674	119516	16498
3 7/8	3,875	5,709	3,937	4,409	M 12	105	19297	119516	16498
3 15/16	3,938	5,709	3,937	4,409	M 12	105	19608	119516	16498
4	4,000	5,709	3,937	4,409	M 12	105	19919	119516	16498
4 1/4	4,250	6,102	3,937	4,409	M 12	105	21164	119516	15436
4 3/8	4,375	6,102	3,937	4,409	M 12	105	21787	119516	15436
4 7/16	4,438	6,496	3,937	4,409	M 12	105	25781	139436	16916
4 1/2	4,500	6,496	3,937	4,409	M 12	105	26144	139436	16916
4 3/4	4,750	6,496	3,937	4,409	M 12	105	27597	139436	16916
4 15/16	4,938	7,087	4,567	5,118	M 14	166	33469	162686	15656
5	5,000	7,087	4,567	5,118	M 14	166	33893	162686	15656
5 1/4	5,250	7,480	4,567	5,118	M 14	166	41519	189800	17306
5 7/16	5,438	7,480	4,567	5,118	M 14	166	43002	189800	17306
5 1/2	5,500	7,480	4,567	5,118	M 14	166	43496	189800	17306
5 3/4	5,750	7,874	4,567	5,118	M 14	166	51969	216915	18788
5 15/16	5,938	7,874	4,567	5,118	M 14	166	53664	216915	18788
6	6,000	8,268	4,567	5,118	M 14	166	54229	216915	17228
6 7/16	6,438	8,858	5,748	6,378	M 16	257	69732	259972	15532
6 1/2	6,500	8,858	5,748	6,378	M 16	257	70409	259972	15532
6 15/16	6,938	9,252	5,866	6,496	M 16	257	80516	278541	15933
7	7,000	9,252	5,866	6,496	M 16	257	81241	278541	15933
7 1/4	7,250	9,843	5,866	6,496	M 16	257	89752	297111	15975
7 7/16	7,438	9,843	5,866	6,496	M 16	257	92073	297111	15975
7 1/2	7,500	9,843	5,866	6,496	M 16	257	92847	297111	15975
7 3/4	7,750	10,236	5,866	6,496	M 16	257	95942	297111	15361
7 15/16	7,938	10,236	5,866	6,496	M 16	257	98263	297111	15361
8	8,000	10,236	5,866	6,496	M 16	257	99037	297111	15361

CONEX H - CONEX I - CONEX M

CONEX H - CONEX I

Montaggio e smontaggio rapidi

Quick mounting and removal



CONEX M

Collega due alberi coassiali

For connection of coaxial shafts



CONEX H

d	D	D ₁	B	L	T _N	T	F	P
mm	mm	mm	mm	mm	Nm	Nm	kN	N/mm ²
14	25	32	6,5	16,5	65	37	6	73
15	25	32	6,5	16,5	65	40	6	73
16	25	32	6,5	16,5	65	42	6	73
17	25	38	6,5	16,5	75	63	7	80
18	30	38	7	17	85	65	8	80
19	30	38	7	17	95	60	7	70
20	30	38	7	17	110	70	8	80
22	35	45	7	17	130	80	9	80
24	35	45	7	17	155	100	10	80
25	35	45	7	17	160	110	10	90
28	40	52	8	20	200	140	11	70
30	40	52	8	20	240	170	14	80
32	45	58	9	22	320	210	15	80
35	45	58	9	22	320	230	15	80
38	50	65	9	23	440	300	19	87
40	50	65	9	23	440	330	19	90
42	55	70	10	25	550	400	23	92
45	55	70	10	25	550	440	23	90
50	60	75	10	25	660	530	25	90
55	65	80	12	29,5	800	640	27	80
60	70	85	12	29,5	900	830	32	80
70	84	98	14	31,5	1100	1100	31	90

CONEX I

d	D	D ₁	B	L	T _N	T	F	P
mm	mm	mm	mm	mm	Nm	Nm	kN	N/mm ²
14	25	32	17	29	90	90	15	80
15	25	32	17	29	90	100	15	80
16	25	32	17	29	70	80	12	60
17	25	38	18	31	90	113	12	70
18	30	38	18	31	190	200	25	110
19	30	38	18	31	150	170	20	90
20	30	38	18	31	110	130	15	60
22	35	45	22	35	130	180	18	60
24	35	45	22	35	230	270	26	80
25	35	45	22	35	170	200	20	60
28	40	52	22	35	390	460	40	110
30	40	52	22	35	240	300	24	70
32	45	58	27	42	320	420	31	70
35	45	58	28	42	320	460	31	60
40	50	65	28	44	440	640	37	70
45	55	70	28	45	550	760	40	60
50	60	75	28	46	660	930	44	60
55	65	80	28	47	800	1130	47	60
60	70	85	28	52	1050	1500	59	70

CONEX M

d	D	B	L	M	T _s	T	F
mm	mm	mm	mm	mm	Nm	Nm	kN
10	35	38	42	M 4	5,5	62	12
11	35	38	42	M 4	5,5	66	12
12	35	38	42	M 4	5,5	72	12
14	35	38	42	M 4	5	76	11
15	45	50	56	M 6	17	160	23
16	45	50	56	M 6	17	170	23
17	45	50	56	M 6	17	180	23
18	50	50	56	M 6	17	190	23
19	50	50	56	M 6	17	200	23
20	50	50	56	M 6	17	220	23
22	55	60	66	M 6	17	360	33
24	55	60	66	M 6	17	390	33
25	55	60	66	M 6	17	400	33
28	60	60	66	M 6	17	390	29
30	60	60	66	M 6	17	420	29
32	75	75	83	M 8	41	610	39
35	75	75	83	M 8	41	670	39
38	75	75	83	M 8	41	730	39
40	75	75	83	M 8	41	760	39
42	85	85	93	M 8	41	1170	57
45	85	85	93	M 8	41	1260	57
48	90	85	93	M 8	41	1360	57
50	90	85	93	M 8	41	1400	57
55	95	85	93	M 8	41	2000	76
60	100	85	93	M 8	41	2260	76
65	105	85	93	M 8	41	2500	77
70	115	100	110	M 10	83	3300	95
75	120	100	110	M 10	83	3500	95
80	125	100	110	M 10	75	3900	100
90	136	100	110	M 10	75	5100	113
100	158	120	132	M 12	130	8350	167

T _N (Nm)	Coppia di serraggio ghiera	Nut tightening torque
T (Nm)	Coppia massima o forza assiale trasmissibili	Transmissible pick torque or axial force with nut tightening torque T _N
F (kN)	con coppia di serraggio ghiera T _N	
p (N/mm ²)	Pressione superficiale sul mozzo	Hub surface pressure

CONEX H CONEX I

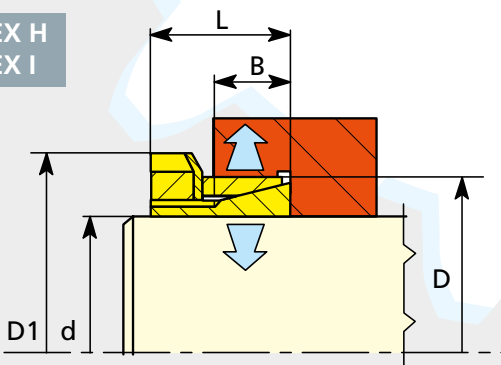

CONEX M

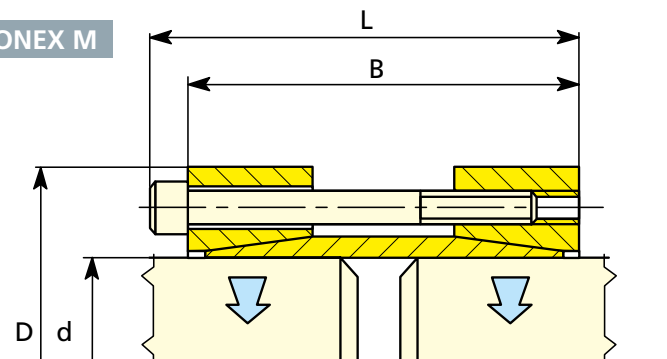

CONEX L - CONEX K

CONEX L

**Autocentrante
coppie medie**

*Self centering
medium torques*



CONEX K

**Autocentrante
coppie medie**

*Self centering
medium torques*



CONEX L

d mm	D mm	B mm	L mm	M mm	T _s Nm	T Nm	F kN	P N/mm ²
16	32	17	21	M 4	5	80	13	68
18	40	18	24	M 6	17	180	24	100
19	41	18	24	M 6	17	190	24	100
20	42	18	24	M 6	17	200	24	100
22	44	18	24	M 6	17	220	24	90
24	46	18	24	M 6	17	360	36	130
25	47	18	24	M 6	17	380	36	130
28	50	18	24	M 6	17	420	36	120
30	52	18	24	M 6	17	450	36	120
32	54	18	24	M 6	17	480	36	110
35	57	22	28	M 6	17	700	36	90
38	60	22	28	M 6	17	750	36	85
40	62	22	28	M 6	17	800	36	80
42	70	28	36	M 8	41	1500	90	135
45	73	28	36	M 8	41	1700	90	130
48	76	28	36	M 8	41	1780	90	123
50	78	28	36	M 8	41	1840	90	120
55	83	28	36	M 8	41	2000	90	130
60	88	28	36	M 8	41	2200	90	100
65	93	28	36	M 8	41	2400	110	110
70	105	35	45	M 10	80	4100	150	125
75	110	35	45	M 10	80	4400	150	120
80	115	35	45	M 10	80	4700	150	115
85	120	35	45	M 10	80	5500	180	125
90	125	35	45	M 10	80	5800	180	120
100	138	35	45	M 10	80	6500	180	110

CONEX K

d mm	D mm	B mm	L mm	M mm	T _s Nm	T Nm	F kN	P N/mm ²
5	16	11	13,5	M 2,5	1,2	5	2	55
6	16	11	13,5	M 2,5	1,2	6	2	55
6,35	16	11	13,5	M 2,5	1,2	6	2	55
7	17	11	13,5	M 2,5	1,2	8	2	55
8	18	11	13,5	M 2,5	1,2	10	2,5	50
9	20	13	15,5	M 2,5	1,2	15	3	55
9,53	20	13	15,5	M 2,5	1,2	15	3	55
10	20	13	15,5	M 2,5	1,2	15	3	55
11	22	13	15,5	M 2,5	1,2	18	3	50
12	22	13	15,5	M 2,5	1,2	20	3	50
14	26	17	20	M 3	2,1	35	5	55
15	28	17	20	M 3	2,1	40	5	50
16	32	17	21	M 4	4,9	70	8	65
17	35	21	25	M 4	4,9	75	8	60
18	35	21	25	M 4	4,9	80	8	60
19	35	21	25	M 4	4,9	85	8	60
20	38	21	26	M 5	9,7	150	15	75
22	40	21	26	M 5	9,7	160	14	70
24	47	26	32	M 6	16,5	250	20	75
25	47	26	32	M 6	16,5	260	20	75
28	50	26	32	M 6	16,5	440	30	100
30	55	26	32	M 6	16,5	470	30	95
32	55	26	32	M 6	16,5	500	30	95
35	60	31	37	M 6	16,5	730	40	95
38	65	31	37	M 6	16,5	800	40	90
40	65	31	37	M 6	16,5	840	40	90
45	75	36	44	M 8	40	1300	55	90
50	80	36	44	M 8	40	1900	75	115

CONEX L

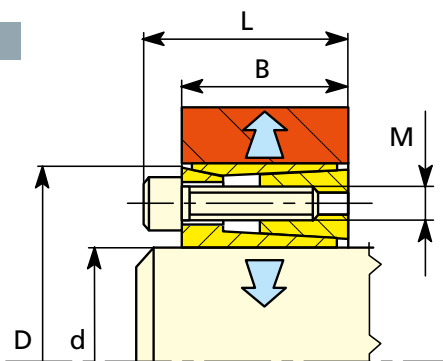

CONEX K

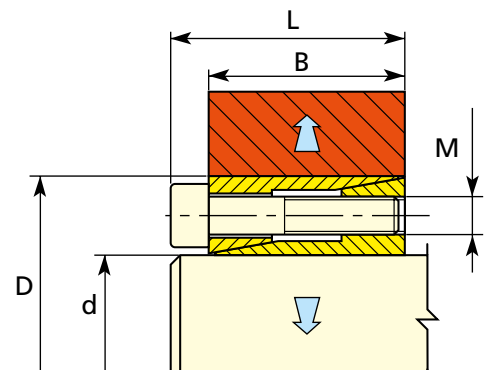

CONEX FC - Giunto Rigido Flangiato / Rigid Flange Coupling

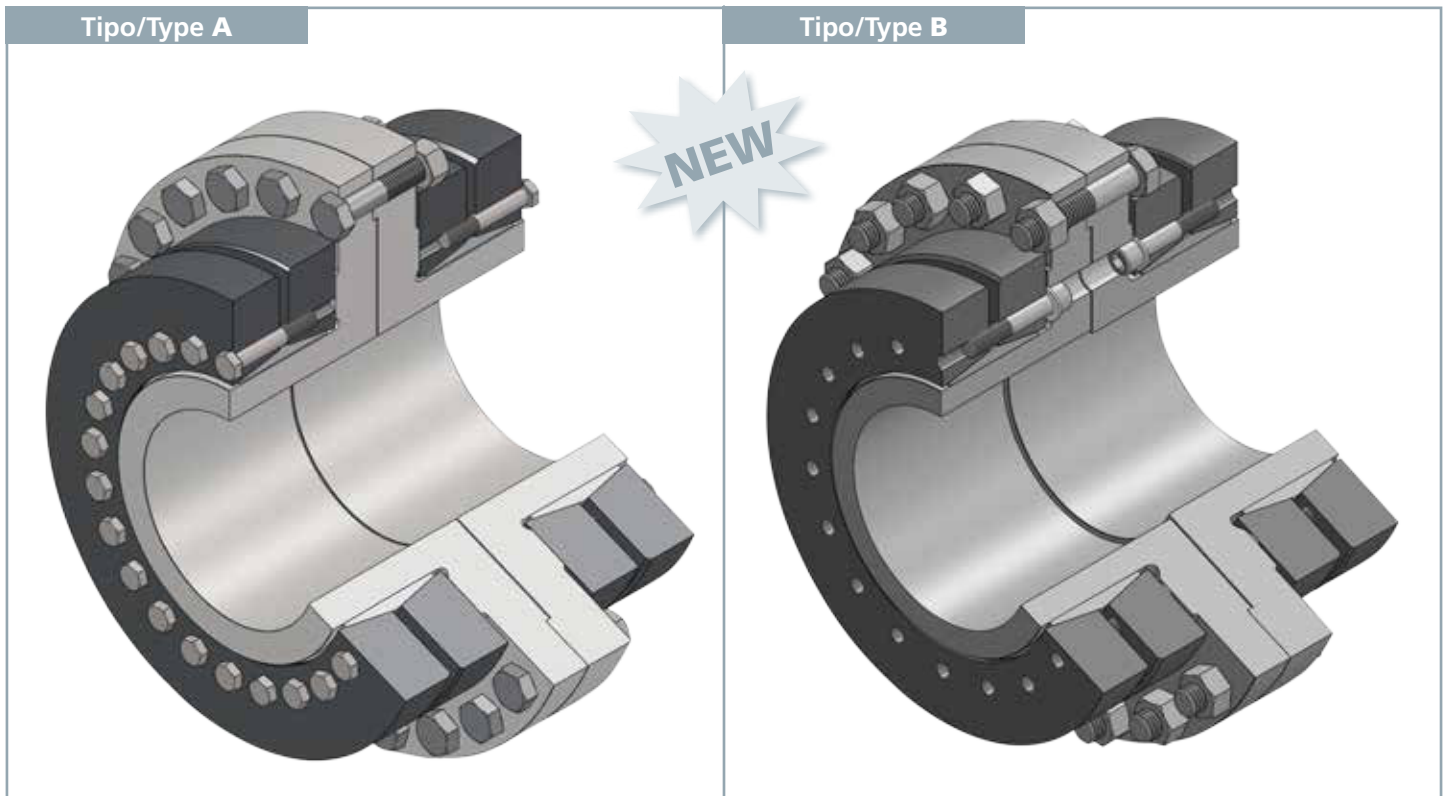

Conex FC: Come lavora

CONEX FC è un giunto rigido, senza gioco, che trasmette coppie elevate, e impiega come elementi di trasmissione due flange, collegate tra loro con viti ad alta resistenza.

Su ogni flangia è montato un calettatore per esterni CONEX SD, le cui istruzioni di montaggio e smontaggio sono indicate a pag. 7.

Istruzioni per montaggio e smontaggio CONEX FC

- Montare le flange sugli alberi da collegare controllando che gli alberi non sporgano e siano posizionati secondo i disegni di montaggio. Per rendere più facile il montaggio sugli alberi, le flange possono essere riscaldate a una temperatura da 80°C a 120°C.
- Condizione essenziale per la trasmissione della coppia di catalogo è la pulizia e lo sgrassaggio delle superfici di contatto e dei centraggi tra le due flange, delle superfici tra albero e mozzo, e il rispetto delle tolleranze e delle rugosità indicate nella tabella dei dati tecnici dei CONEX SD.
- Serrare i dadi del giunto con chiave dinamometrica in sequenza, 25%-50%-75%-100% delle coppie di serraggio.
- Per smontare il giunto, allentare in sequenza le viti e i dadi di collegamento delle flange. Non smontare le viti del calettatore fino a che le flange non sono sbloccate **!Pericolo per l'operatore.**

Conex FC: How it works

CONEX FC is a rigid coupling, without backlash, which transmits high torques, using two flanges as transmission elements, connected each other with high-strength screws.

On each flange a Shrink Disc CONEX SD is mounted, whose assembly and disassembly instructions are indicated on page 7.

Assembly / disassembly instructions for CONEX FC

- Mount the flanges on the shafts to be connected, by checking that the shafts do not protrude and are positioned according to the installation drawings. To make the shafts assembly easier, the flanges can be heated at a temperature from 80°C to 120°C.
- The essential condition to transmit the catalogue torque values is to clean and degrease the contact surfaces and the centering between the 2 flanges, between the shafts and the flanges, and to respect the tolerances and the roughness as indicated on the technical charts CONEX SD.
- Tighten the nuts of the coupling with a torque wrench, in sequence 25%, 50%, 75%, 100% of the tightening torques.
- To disassemble the coupling, release in sequence the screws and nuts of the connecting flanges. Do not remove the screws of the clamping elements until the flanges are not released. **Dangerous for the operator!**

CONEX FC

**Tipo
Type
A**

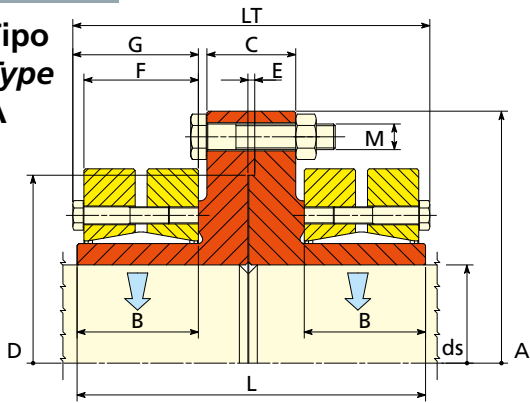

Tolleranze / Fit Tolerance

ds		ISO	gioco max max clearance
da / from	a / to		
18	30	H 6 / j 6	0,017
30	50	H 6 / h 6	0,032
50	80	H 6 / g 6	0,048
80	120	H 7 / g 6	0,069
120	180		0,079
180	250		0,090
250	315		0,101
315	400		0,111
400	500		0,123
500	630		0,136

CONEX FC

**Tipo
Type
B**

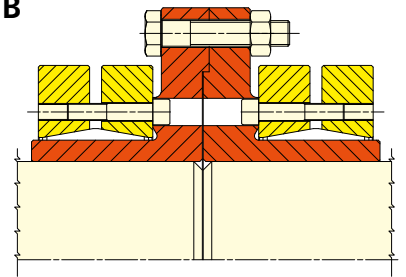

Grand. Size	SD			Giunto rigido flangiato / Rigid coupling flange											Viti collegamento flange Flange connection bolts			
	ds mm	T Nm	Grand. Size	Dimensioni d'ingombro / Overall dimensions											Peso Weight kg	Viti Screws M	Qt nr.	Ts Nm
				Ts Nm	A mm	B mm	C mm	D mm	E mm	F mm	G mm	L mm	LT mm					
FC-80	70-75-80	6900-7500-9000	100x170	30	240	44	44	170	4	44	49,5	136	147	26	M16	6	210	
FC-100	85-90-95-100	11000-13000 15000-17500	125x215	59	305	54	48	215	5	52	58,5	160	169	48	M20	6	420	
FC-110	90-95-100-110	13700-15800 18200-23500	130x215	59	340	54	56	230	5	52	58,5	170	179	56	M24	5	720	
FC-115	95-100-105-115	15000-17000 20000-26000	140x230	100	340	64	56	230	5	60	67,5	190	197	63	M24	5	720	
FC-135	115-120-125-135	36000-39000 40000-51200	165x290	250	400	75	72	300	5	71	81	228	240	120	M24	8	720	
FC-140	125-130-135-140	40000-44000 49000-52500	175x300	250	400	75	72	300	5	71	81	228	240	120	M24	8	720	
FC-165	140-150-155-165	66000-76000 82000-96000	195x350	250	475	90	90	350	6	86	96	278	290	215	M30	10	1800	
FC-180	160-165-170-180	95000-102000- 110000-128000	220x370	250	510	108	90	370	6	104	114	314	326	270	M30	14	1800	
FC-200	170-180-190-200	120000-140000 160000-182000	240x405	490	540	113	88	405	6	109	121,5	322	339	310	M30	16	1800	
FC-220	190-200-210-220	165000-185000 204000-232000	260x430	490	560	125	110	430	8	120	132,5	368	383	395	M30	16	1800	
FC-240	210-220-230-240	216000-245000 270000-300000	280x460	490	590	139	104	460	8	134	146,5	392	407	445	M30	18	1800	
FC-260	230-240-250-260	274000-296000 332000-364000	300x485	490	615	147	104	485	8	142	154,5	408	423	500	M30	20	1800	
FC-290	250-260 270-280-290	352000-385000 420000-505000-550000	340x570	490	710	161	118	570	8	156	168,5	450	465	780	M30	24	1800	
FC-320	280-290-300-320	462000-500000 530000-600000	360x590	490	720	167	106	590	8	162	174,5	450	465	790	M30	24	1800	
FC-340	300-310-320-340	625000-670000 720000-790000	390x660	840	805	180	114	660	8	168	183	484	490	1060	M30	28	1800	
FC-360	330-340-350-360	782000-841000 902000-960000	420x690	840	835	198	122	690	10	188	203	528	538	1230	M30	30	1800	
FC-390	360-370-380-390	1000000-1073000 1141000-1215000	460x770	840	920	208	130	770	10	202	217	556	574	1420	M30	35	1800	
FC-430	400-410-420-430	1314000-1382000 1460000-1540000	500x850	1250	1030	225	156	850	12	213	230	618	628	2200	M36	32	3100	
FC-460	430-440-450-460	1788000-1881000 1976000-2080000	530x900	1250	1100	258	160	900	14	240	257	696	694	2680	M36	36	3100	
FC-500	470-480-490-500	2305100-2410000 2528100-2650000	590x980	1250	1180	280	164	980	14	265	282	744	748	3340	M36	40	3100	
FC-540	500-510-520-540	2634100-2740000 2860100-3120000	620x1020	1250	1210	280	164	1020	14	265	282	744	748	3620	M36	42	3100	

**Tipo / Type
A - B**

Viti ISO 4017 Cl.10,9 fino FC-140 compreso / Screws ISO-4017 Cl.10,9 up FC-140 including

Dadi ISO 4032 Cl.10 / Nuts Iso 4032 Cl. 10

Viti ISO 4017 Cl.12,9 dal FC-165 compreso / Screws ISO-4017 Cl.12,9 from FC-165 including

Dadi ISO 4032 Cl.10 / Nuts Iso 4032 Cl. 10

CONEX P

**Per uso con alti momenti flettenti.
Autocentrante - coppie molto alte.**
Durante il bloccaggio il mozzo
rimane fisso assialmente.

**For use with high bending moments.
Self centering - very high torque.**
During the clamping the hub
remains axially fixed.



CONEX P

d	D	D ₁	A	A ₁	B	L	M ₁	Ts ₁	M ₂	Ts ₂	T ₁	T ₂	T _T	F ₁	F ₂	F _T	P ₁	P ₂
mm	mm	mm	mm	mm	mm	mm	M	Nm	M	Nm	Nm	Nm	Nm	kN	kN	kN	N/mm ²	N/mm ²
100	150	156	61	26	82	96	M 14	230	M 12	145	11900	8900	20800	238	178	416	162	121
110	160	166	61	26	82	96	M 14	230	M 12	145	13200	9800	23000	240	178	418	154	114
120	170	176	61	26	82	96	M 14	230	M 12	145	14400	10500	24900	240	175	415	145	106
130	190	196	71	30	95	111	M 16	355	M 14	230	24300	17700	42000	374	272	646	174	127
140	200	206	71	30	95	111	M 16	355	M 14	230	26000	19000	45000	371	271	643	165	120
150	210	216	71	30	95	111	M16	355	M 14	230	27400	19900	47300	365	264	629	154	111
160	220	226	71	30	95	111	M 16	355	M 14	230	29900	21900	51800	374	274	648	150	110
170	240	246	92	40	122	142	M 20	690	M 16	355	49200	31600	80800	579	372	951	145	103
180	250	256	92	40	122	142	M 20	690	M 16	355	53000	34000	87000	589	378	967	156	100
190	260	266	92	40	122	142	M 20	690	M 16	355	64500	41500	106000	679	437	1116	173	111
200	270	276	92	40	122	142	M 20	690	M 16	355	73700	47100	120800	737	471	1208	182	116
220	290	296	92	40	122	142	M 20	690	M 16	355	81000	51800	132800	736	471	1207	169	108
240	310	316	92	40	122	142	M 20	690	M 16	355	106500	67900	174400	888	566	1453	190	121
260	330	336	92	40	122	142	M 20	690	M 16	355	114600	73500	188100	882	565	1447	177	114
280	365	374	108	45	144	168	M 24	1200	M 20	690	150200	103500	253700	1073	739	1812	173	119
300	385	394	108	45	144	168	M 24	1200	M 20	690	161300	110600	271900	1075	737	1813	165	113
320	405	414	108	45	144	168	M 24	1200	M 20	690	204500	140200	344700	1278	876	2154	187	128
340	425	434	108	45	144	168	M 24	1200	M 20	690	255700	175500	431200	1504	1032	2536	208	143
360	445	454	108	45	144	168	M 24	1200	M 20	690	269000	184500	453500	1494	1025	2519	198	136
380	465	474	108	45	144	168	M 24	1200	M 20	690	326800	224300	551100	1720	1181	2901	218	149
400	485	494	108	45	144	168	M 24	1200	M 20	690	344000	235400	579400	1720	1177	2897	209	144
420	505	514	108	45	144	168	M 24	1200	M 20	690	359500	246400	605900	1712	1173	2885	200	137
440	525	534	147	59	178	202	M 24	1200	M 20	690	376700	258500	635200	1712	1175	2887	147	101
460	545	554	147	59	178	202	M 24	1200	M 20	690	393900	269600	663500	1713	1172	2885	141	97
480	565	574	147	59	178	202	M 24	1200	M 20	690	410000	281700	691700	1708	1174	2882	136	94
500	585	594	147	59	178	202	M 24	1200	M 20	690	480700	330200	810900	1923	1321	3244	147	102
520	605	614	147	59	178	202	M 24	1200	M 20	690	499900	343400	843300	1923	1321	3243	143	98
540	625	634	147	59	178	202	M 24	1200	M 20	690	519100	356500	875600	1923	1320	3243	138	95
560	645	654	147	59	178	202	M 24	1200	M 20	690	538300	369600	907900	1923	1320	3243	134	92
580	665	674	147	59	178	202	M 24	1200	M 20	690	620100	425200	1045300	2138	1466	3604	144	99
600	685	694	147	59	178	202	M 24	1200	M 20	690	640000	440000	1080000	2133	1467	3600	140	97

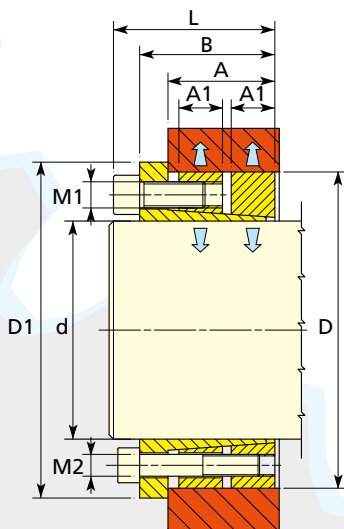

fino a d 420 / up to d 420

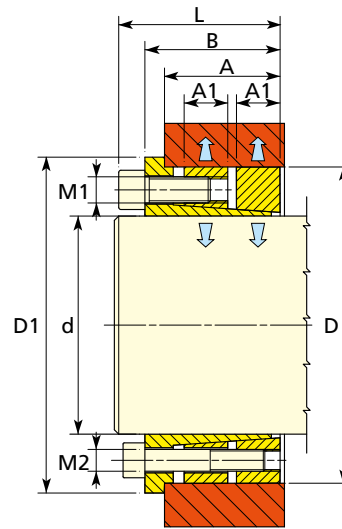

da d 440 compreso / d 440 and larger sizes

Conex P - Montaggio

- Pulire e lubrificare le superfici di contatto, inclusi i filetti, le teste delle viti, l'albero e il mozzo. Non usare oli contenenti additivi per le alte pressioni (M_0S_2).
- Svitare tutte le viti di 2 - 3 giri e avvitare almeno 3 viti grandi (4) nei fori di estrazione della flangia (1), serrarle leggermente in modo da sbloccare gli anelli (2 + 3), questa operazione agevola il montaggio del calettatore (Fig.1). Togliere le viti (4) dai fori di estrazione e riposizionarle nei rispettivi fori filettati.
- Serrare le viti grandi (4) dell'anello di spinta centrale (2) con sequenza a croce in più stadi fino a raggiungere la coppia di catalogo Ts_1 .
- Ripetere l'operazione con coppia Ts_2 per le rimanenti viti piccole (5).
- Dopo il serraggio delle viti piccole (5), ricontrollare la coppia di serraggio di tutte le viti (4 + 5).

Conex P - Smontaggio

- Svitare le viti grandi (4) di 4 - 5 giri (Fig. 1); trasferire le viti grandi necessarie nei fori di estrazione (Fig. 2).
- Serrare le viti (4) nei fori di estrazione per sbloccare l'anello centrale interno (2 - Fig. 3), le viti (5) sono ancora serrate.
- Svitare le viti piccole (5) di 4 - 5 giri (Fig. 4), serrare nuovamente le viti (4) nei fori di estrazione fino allo sbloccaggio dell'anello posteriore (3 - Fig. 4).

Conex P - Installation

- Clean and slightly oil all the contact surfaces, including screw threads, screw heads, shaft and hub. Do not use oils containing high pressure additives (M_0S_2).
- Release all the screws for 2 - 3 turns and screw at least 3 of the large screws (4) in to the release threads of the front flange (1) in order to release the thrust rings (2 + 3); this step grants an easier mounting of the Conex P.
- Remove the screws (4) from the release threads of the front flange and screw them in to the threads of the central thrust ring (2).
- Tighten the large screws (4) in diametrically opposite sequence in several stages up to the catalogue torque Ts_1 .
- Repeat this operation for the small screws (5) with tightening torque Ts_2 .
- Re-check the tightening torque of all the screws (4 + 5).

Conex P - Removal

- Release the large screws (4) for 4 - 5 turns (Fig. 1); transfer the necessary screws in to the release threads (Fig. 2).
- Tighten the large screws (4) in to the release threads, to release the central thrust ring (2) - Fig. 3, the screws (5) are still tighten.
- Release the small screws (5) for 4 - 5 turns (Fig. 4). Tighten again the large screws (4) in to the release threads to release the rear thrust ring (3) - Fig. 4.

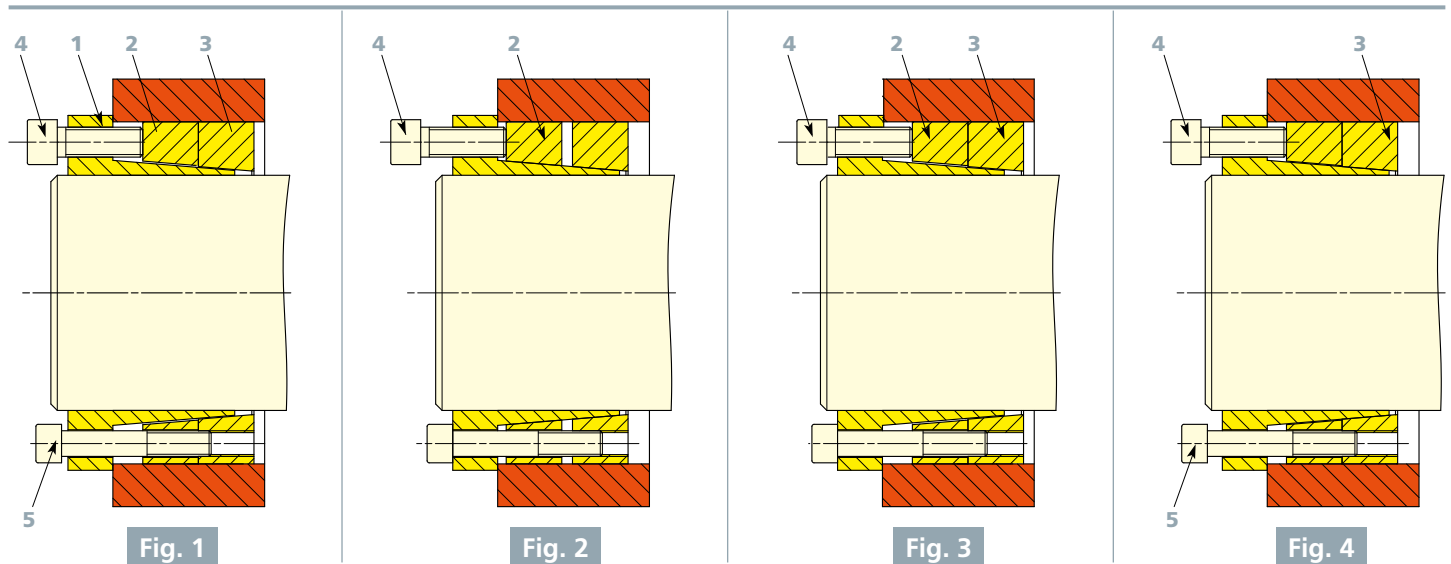

1 Flangia frontale / Frontal flange - 2 Anello di spinta centrale / Central thrust ring - 3 Anello di spinta posteriore / Rear thrust ring
4 Viti grandi / Large screws - 5 Viti piccole / Small screws

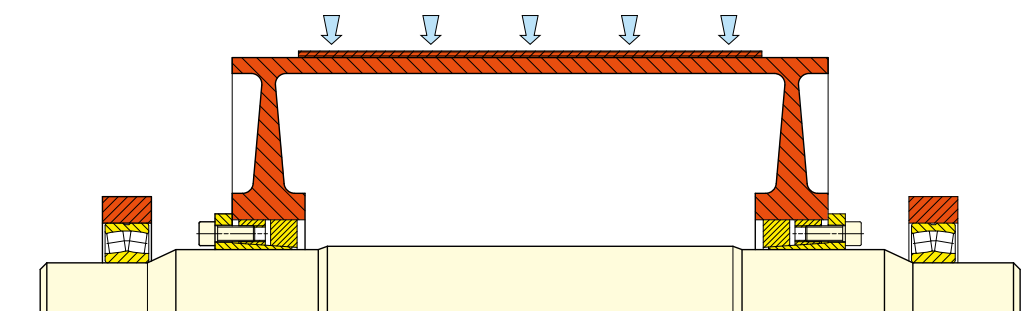

MIDAS - CONEX EP

MIDAS

CONEX EP

Modular Systems

Brevettato
Patented



MIDAS								T_s Nm	T Nm	F kN	P N/mm ²
Midas	d mm	D mm	D ₁ mm	A mm	B mm	L mm	M mm				
2614	10 - 11 - 12	26	40,5	14	27,5	31,5	M 4	5	40 - 50 - 55	10	100
	14 - 15 - 16								90 - 95 - 115	14	
	18 - 19 - 20								130 - 140 - 145		
3814	19 - 20 - 22	38	57	14	33	39	M 6	17	195 - 200 - 240	22	104
	24 - 25 - 28 - 30								265 - 275 - 310 - 330		
3827	19 - 20 - 22	38	57	27	46	52	M 6	17	310 - 330 - 360	34	81
	24 - 25 - 28 - 30								400 - 410 - 460 - 500		
5227	24 - 25 - 28 - 30	52	70,5	27	46	52	M 6	17	470 - 490 - 550 - 590	44	79
	32 - 35 - 38 - 40 - 42								700 - 770 - 840 - 880 - 920		
7237	28 - 30 - 32 - 35	72	96,5	37	60	68	M 8	41	1240 - 1330 - 1420 - 1550	105	99
	38 - 40 - 42 - 45								1780 - 1880 - 1970 - 2110		
	48 - 50 - 55 - 60								2250 - 2350 - 2590 - 2820		

CONEX EP								T_s Nm	T Nm	F kN	P N/mm ²
EP	d mm	D mm	D ₁ mm	A mm	B mm	L mm	M mm				
55	14 - 16	55	62	22	30	38	M 8	41	287 - 329	41	103
	18 - 19 - 20	55	62	22	30	38	M 8	41	370 - 390 - 410	41	103
	22 - 24 - 25	55	62	22	30	38	M 8	41	451 - 492 - 513	41	103
	28 - 30	55	62	22	30	38	M 8	41	575 - 616	41	103
65	24 - 25	65	72	22	30	38	M 8	41	616 - 641	51	111
	28 - 30 - 32	65	72	22	30	38	M 8	41	718 - 770 - 821	51	111
	35 - 38 - 40	65	72	22	30	38	M 8	41	898 - 975 - 1026	51	111
80	30 - 32 - 35	80	88	25	33	41	M 8	41	1077 - 1150 - 1257	72	108
	38 - 40	80	88	25	33	41	M 8	41	1364 - 1436	72	108
	42 - 45 - 48 - 50	80	88	25	33	41	M 8	41	1509 - 1616 - 1723 - 1796	72	108

MIDAS

Diametri esterni uguali e interni variabili. Dimensioni radiali ridotte

The same outer diameter and a range of inner diameters. Small radial dimensions

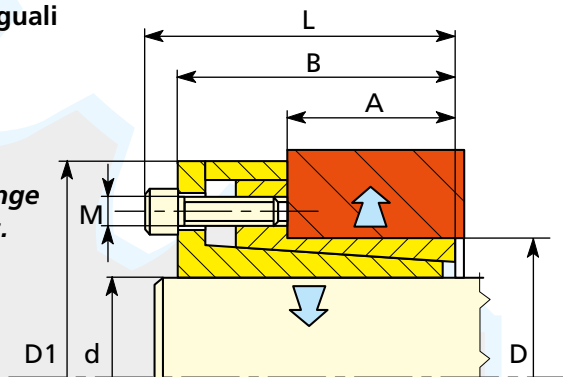

CONEX EP

Diametri esterni uguali e interni variabili

The same outer diameter and a range of inner diameters

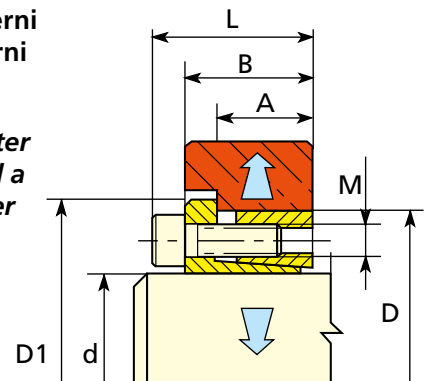

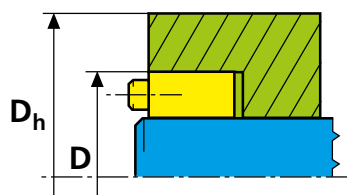

f = 0,6

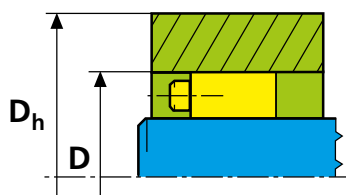

f = 0,8

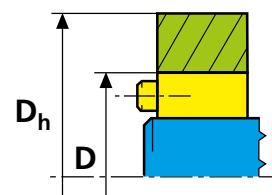

f = 1

D_h = Diametro esterno minimo del mozzo / *Smallest hub outer diameter*

P N/mm ²	f	C G25 σ = 180 N/mm ²	C St 37 σ = 220 N/mm ²	C C 40 σ = 300 N/mm ²
		60	0,6	1,25
	0,8	1,30	1,23	1,18
	1	1,42	1,32	1,22
80	0,6	1,31	1,25	1,18
	0,8	1,45	1,35	1,24
	1	1,61	1,46	1,31
100	0,6	1,41	1,32	1,22
	0,8	1,61	1,46	1,31
	1	1,86	1,63	1,41
130	0,6	1,59	1,45	1,30
	0,8	1,93	1,67	1,44
	1	2,49	1,97	1,59
160	0,6	1,81	1,60	1,39
	0,8	2,43	1,94	1,58
	1	4,12	2,52	1,81

p pressione sul mozzo
hub surface pressure

f coefficiente di forma
form factor

σ limite snervamento del mozzo
hub material yield point

C $D_{h \min} = c \cdot D$

Tolleranze albero ①,
sede mozzo ②
e rugosità superfici ③

Shaft ① *and hub bore*
② *fit tolerances and*
surfaces roughness ③

CONEX	①	②	③
A	k11 - h11	N11 - H11	$R_a \leq 3.2 \mu\text{m}$
SA - SB - ds ≤ 160	h6	H7	$R_a \leq 3.2 \mu\text{m}$
ds > 160	g6	H7	$R_a \leq 3.2 \mu\text{m}$
SD - FC - ds < 30	j6	H6	$R_a \leq 3.2 \mu\text{m}$
30 < ds < 50	h6	H6	$R_a \leq 3.2 \mu\text{m}$
50 < ds < 80	g6	H6	$R_a \leq 3.2 \mu\text{m}$
80 < ds < 500	g6	H7	$R_a \leq 3.2 \mu\text{m}$
C - d < 38	h6	H7	$R_a \leq 1 \mu\text{m}$
d > 38	h8	H8	$R_a \leq 1 \mu\text{m}$
B - D - DS - E - ES - F - FS - FL G - H - I - L - M - K - MIDAS - EP - P	h8	H8	$R_a \leq 3.2 \mu\text{m}$

Coefficiente di servizio Duty factor

I valori di catalogo T e F devono essere corretti con adeguato coefficiente di servizio, in funzione dell'applicazione.

The values T and F on the catalogue must be corrected with a duty factor depending from the type of work.

Motore Motor	Carico / Load		
	uniforme constant	leggeri sovraccarichi light overloads	forti sovraccarichi heavy overloads
elettrico electric	1	1,5	2
a scoppio combustion	1,5	2	2,5

CONEX - Montaggio

Pulire e lubrificare tutte le superfici di contatto, inclusi i filetti, le teste delle viti, l'albero e il mozzo. Non usare oli contenenti additivi per alte pressioni ($M_0 S_2$).

Iniziare ad avvitare le viti e posizionare il mozzo. Serrare le viti con sequenza a croce in più stadi fino a raggiungere la coppia di catalogo T_c . Ricontrrollare la coppia di serraggio di tutte le viti.

Solo per CONEX A: le viti argentate devono essere avvitate nei fori con filetto di estrazione nell'anello conico anteriore.

CONEX SA, SB: vedi istruzioni pag. 6.

CONEX SD: vedi istruzioni pag. 7.

Per tutti gli altri CONEX, i filetti di estrazione dell'anello conico anteriore, impiegati per lo smontaggio, devono essere in corrispondenza di spazi non forati e non tagliati sul cono posteriore, ed eventualmente impiegati per sbloccare CONEX prima del montaggio.

Per Conex F, FS, FL, G, vedi sequenza di serraggio viti (fig. 7).

CONEX - Smontaggio

Sbloccare le viti di qualche giro.

CONEX A. Normalmente il semplice sbloccaggio delle viti ne provoca lo sbloccaggio a causa dell'ampio angolo dei coni: se necessario, battere leggermente sulle viti per sbloccare l'anello conico posteriore (fig. 1). Se l'anello conico anteriore è bloccato, rimuovere le viti argentate sotto le quali si trovano i filetti di estrazione; su di essi avvitare le viti di estrazione e tirare (fig. 2). I fori di estrazione sono parzialmente filettati. Le viti di estrazione sono di una grandezza superiore alle viti di montaggio.

CONEX SD. Il semplice sbloccaggio delle viti ne provoca lo sbloccaggio a causa dell'ampio angolo dei coni: se necessario, battere leggermente sulle viti per sbloccare l'anello conico posteriore (fig. 3).

CONEX B, D, DS, E, ES, L, K, MIDAS, EP, MIDAS, SA, SB

Rimuovere le viti e avvitare nei fori filettati di estrazione nell'anello conico anteriore, spingere sull'anello conico posteriore e sbloccare CONEX (fig. 4). Togliere le viti dai fori di estrazione solo dopo che CONEX è stato estratto dal mozzo.

CONEX F, FS, FL, G

- Smontaggio 1 (fig. 5 + 7): rimuovere le viti e avvitare nei fori filettati di estrazione nell'anello conico anteriore, sbloccandolo.
- Smontaggio 2 (fig. 6 + 7): avvitare le viti nei fori filettati nella flangia centrale e sbloccare l'anello conico posteriore.

CONEX - Installation

Clean and slightly oil all contact surfaces, including screw threads, screw heads, shaft and hub.

Do not use oils containing Molybdenum Disulphide.

Tighten the screws lightly and align the hub. Tighten the screws in diametrically opposite sequence in several stages up to the catalogue tightening torque T_c . Re-check the tightening torque by applying it to all the screws.

For CONEX A: the silver plated screws are to be fitted in the holes of the front thrust ring with the pull-out threads.

CONEX SA, SB: see instructions page 6.

CONEX SD: see instructions page 7.

For all the others CONEX, the release threads of the front ring, used for removal, have to be positioned opposite to undrilled and uncutted spaces of the rear ring, and eventually used to release CONEX before the mounting.

For Conex F, FS, FL, G see the screws tightening sequence (fig. 7).

CONEX - Removal

Loosen all screws by a few turns.

CONEX A. Normally it releases itself thanks to the wide cone angle; if necessary, lightly tap the screws to release the rear thrust ring (fig. 1).

If the front thrust ring is locked, use screws of next size up, screwed in to the removal pull-out threads, located under the silver plated screws, and pull the front ring off (fig. 2).

The release threads are only partially threaded.

CONEX SD. It releases itself thanks to the wide cone angle; if necessary, lightly tap the screws to release the rear thrust ring (fig. 3).

CONEX B, D, DS, E, ES, L, K, MIDAS, EP, MIDAS, SA, SB

Remove the screws and screw them into the release threads of the front ring, pressing off the rear ring and releasing CONEX (fig. 4). Remove the screws from the release threads only after CONEX has been taken out of the hub.

CONEX F, FS, FL, G

- Dismounting 1 (fig. 5 + 7): Remove the screws and screw them in the threaded bores in the front thrust ring and release it.
- Dismounting 2 (fig. 6 + 7): Screw the screws in the threaded bores in the central flange and release the rear thrust ring.

Smontaggio / Removal

Fig. 1

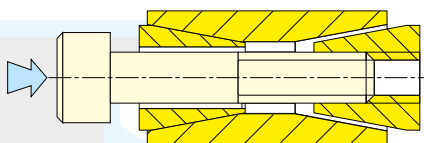

CONEX A

Fig. 3

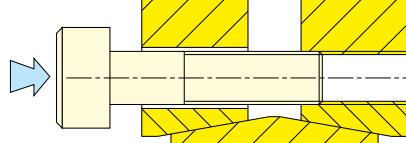

CONEX SD

Fig. 2

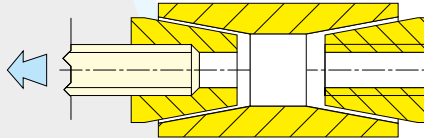
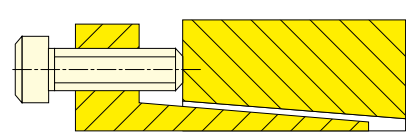
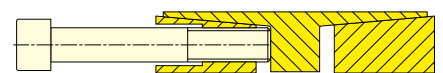

Fig. 4



CONEX B, D, DS, E, ES, L, K, EP, MIDAS, SA, SB

Fig. 5



CONEX F, FS, FL, G

Fig. 6

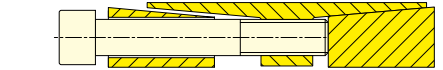

CONEX F, FS, FL, G

Fig. 7

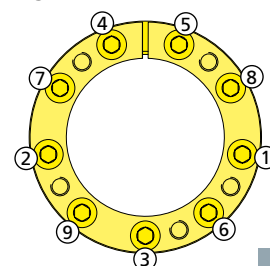

Sequenza di serraggio e sbloccaggio delle viti

Le due viti accanto al taglio devono essere serrate o sbloccate una dopo l'altra per evitare distorsioni degli anelli di spinta.

Screws tightening and release sequence

The 2 screws beside the cut have to be tighten or released one after the other to avoid any distortion of the thrust rings.

CONEX F, FS, FL, G

