



Crossed Roller Bearings

Rolling Bearings

Crossed Roller Bearings

HIWIN crossed roller bearings consist of an inner ring, an outer ring, and cylindrical rollers arranged at 90° with spacers between them. This crosswise arrangement of cylindrical rollers means that only the one bearing can absorb axial forces from both directions, radial forces, overturning torque loads, and any combination of these. HIWIN crossed roller bearings are very rigid with highly compact dimensions and a high running precision.

Crossed Roller Bearings

Contents

Contents

1	Product overview	6
2	General information	8
2.1	Properties	8
2.2	Advantages	8
2.3	Layout of crossed roller bearings	8
2.4	Order code for crossed roller bearings	9
2.5	Crossed roller bearings series	9
2.6	Seals	10
2.7	Accuracy	10
3	Design properties and selection	14
3.1	Selecting a crossed roller bearing	14
3.2	Formulae	14
3.3	Combined fits	17
3.4	Securing and designing the bearing seat and mounting flange	17
3.5	Assembly	20
3.6	Further information	20
4	Crossed roller bearings: series	21
4.1	CRBA	21
4.2	CRBB	22
4.3	CRBC	23
4.4	CRBD	24
4.5	CRBE	25
5	Special crossed roller bearings CRBX	26
5.1	Dimensions	26

Crossed Roller Bearings

Product overview

1. Product overview



Crossed roller bearings CRBA

[Page 21](#)

- Solid inner ring
- Two-part outer ring
- For inner ring rotation



Crossed roller bearings CRBB

[Page 22](#)

- Two-part inner ring
- Solid outer ring
- For outer ring rotation



Crossed roller bearings CRBC

[Page 23](#)

- Solid inner ring
- Solid outer ring
- For inner and outer ring rotation



Crossed roller bearings CRBD

[Page 24](#)

- Two-part outer ring
- For inner ring rotation
- With mounting flange



Crossed roller bearings CRBE

[Page 25](#)

- Solid inner and outer ring
 - For inner and outer ring rotation
 - With mounting flange
-



Crossed roller bearings CRBX

[Page 26](#)

- Individual connecting geometry
 - Individual flange bores
 - Individual surface treatment
-

Crossed Roller Bearings

General information

2. General information

2.1 Properties

HIWIN crossed roller bearings are characterised by high rigidity, very high concentricity, and high torque loading in all directions. Thanks to these advantages, they are ideal for applications e.g. in industrial automation systems, robots, machine tools, precision rotary tables, measuring machines, and medical equipment.

The HIWIN range encompasses six different series of crossed roller bearings.

Series	Typical characteristics	Particularly suitable for
CRBA	Split outer ring	Inner ring rotation
CRBB	Split inner ring	Outer ring rotation
CRBC	Solid inner and outer ring	Inner and outer ring rotation
CRBD	Split outer ring and mounting flange	Inner ring rotation, simplified mounting
CRBE	Solid inner and outer ring and mounting flange	Inner and outer ring rotation, simplified mounting
CRBX	Custom design	Modification to customer requirements

2.2 Advantages

- Patented design for high loadability
- High rigidity
- Simultaneous loading in all directions
- Low-friction rotation
- Compact, space saving design
- Various bearing types and sizes available
- Custom designs possible

2.3 Layout of crossed roller bearings

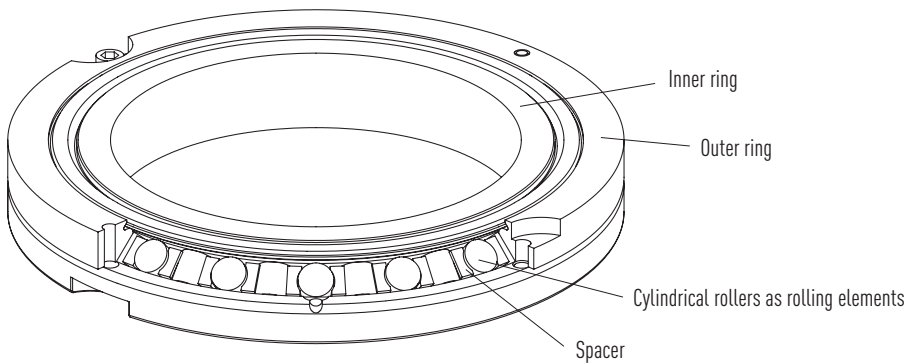

2.4 Order code for crossed roller bearings

CRBD 080 22 A WW C8 P5

Series:

CRBA: With split outer ring
CRBB: With split inner ring
CRBC: With solid inner and outer ring
CRBD: With split outer ring and mounting flange
CRBE: With solid inner and outer ring and mounting flange
CRBX: Customer specific model

Bearing inner diameter

Bearing width

Mounting holes:

Without: No mounting holes¹⁾

A: Threaded holes on the inner ring, countersunk holes on the outer ring²⁾

B: Countersunk holes on the inner and outer ring, same alignment²⁾

C: Countersunk holes on the inner and outer ring, alignment in opposite directions²⁾

Accuracy class:

P2: CRBA, CRBB, CRBC, CRBE

P4: CRBA, CRBB, CRBC³⁾, CRBD, CRBE³⁾

P5: CRBA³⁾, CRBB³⁾, CRBD³⁾

Preload:

C8: Preloaded (standard), see [Table 2.12](#)

C1: Slight play

Seals:

WW: Seals grinding on both sides (standard)

NN: Open type without seals

¹⁾ For CRBA, CRBB, CRBC, CRBX

²⁾ For CRBD, CRBE, CRBX

³⁾ Standard

2.5 Crossed roller bearings series

CRBA

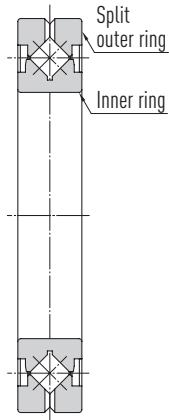

CRBB

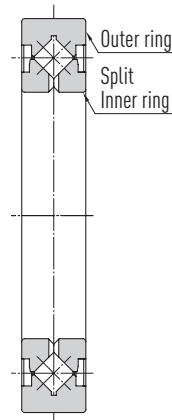

CRBC

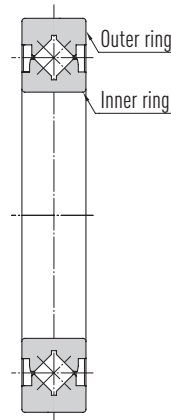

CRBD

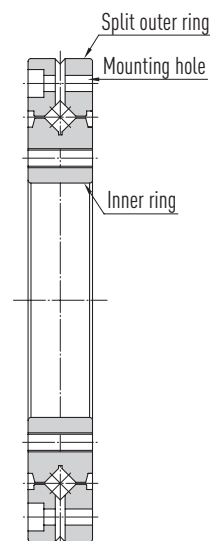

CRBE

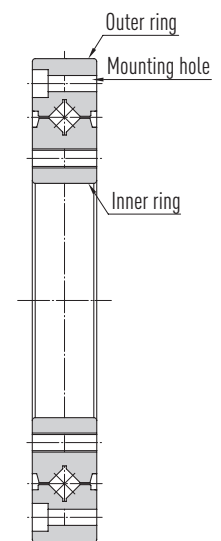

CRBA: Series with split outer ring

Consists of an inner ring and a two-part outer ring and is suitable for inner ring rotation.

CRBB: Series with split inner ring

Consists of an outer ring and a two-part inner ring and is suitable for outer ring rotation.

CRBC: Series with solid outer and inner ring

Consists of an inner ring and an outer ring and is suitable for inner and outer ring rotation.

CRBD: Series with split outer ring and mounting flange

Consists of an inner ring and a two-part outer ring with mounting holes. The bearing can be fitted directly via the mounting holes and is suitable for inner ring rotation

CRBE: Series with solid inner and outer ring and mounting flange

Consists of an inner ring and an outer ring with mounting holes. The model can be fitted directly via the mounting holes and is suitable for inner and outer ring rotation.

CRBX: Series for custom assemblies

These bearings are manufactured to the customer's specific requirements. Also individual surface treatment is possible.

Crossed Roller Bearings

General information

2.6 Seals

Bearings fitted with seals grinding on both sides effectively prevent foreign bodies from penetrating the track and lubricant from leaking out. The open models without seals are characterised by a lower frictional resistance. These bearings are particularly suitable for low-torque applications.

2.7 Accuracy

Table 2.2 Tolerance of the bearing's internal diameter – CRBA, CRBB, CRBC			
Inner diameter d [mm]		Inner diameter tolerances Δd_{mp}	
Over	Up to	High	Low
0	80	-3	-13
80	120	-3	-15
120	150	-4	-18
150	180	-4	-25
180	250	-4	-30
250	315	-5	-35
315	400	-6	-40

Unit: μm

Note: the value d_{mp} is the arithmetic mean of the maximum and minimum internal diameter

Table 2.3 Tolerance of the bearing's internal diameter – CRBD, CRBE			
Inner diameter d [mm]		Inner diameter tolerances Δd_{mp}	
Over	Up to	High	Low
0	30	0	-10
30	50	0	-12
50	80	0	-15
80	120	0	-20
120	150	0	-25
150	180	0	-25
180	250	0	-30
250	315	0	-35
315	400	0	-40

Unit: μm

Note: the value d_{mp} is the arithmetic mean of the maximum and minimum internal diameter

Table 2.4 Tolerance of the bearing's external diameter – CRBA, CRBB, CRBC			
Outer diameter D [mm]		Outer diameter tolerances ΔD_{mp}	
Over	Up to	High	Low
0	120	-3	-15
120	150	-4	-18
150	180	-4	-25
180	250	-4	-30
250	315	-5	-35
315	400	-6	-40
400	500	-7	-45

Unit: μm

Notes: the value D_{mp} is the arithmetic mean of the maximum and minimum outer diameter

Table 2.5 Tolerance of the bearing's external diameter – CRBD, CRBE

Outer diameter D [mm]		Outer diameter tolerances ΔD_{mp}	
Over	Up to	High	Low
0	80	0	-13
80	120	0	-15
120	150	0	-18
150	180	0	-25
180	250	0	-30
250	315	0	-35
315	400	0	-40
400	500	0	-45

Unit: μm

Notes: the value D_{mp} is the arithmetic mean of the maximum and minimum outer diameter

Table 2.6 Tolerance of the inner ring width B and outer ring width T – CRBA, CRBB, CRBC

Width B, T [mm]		Tolerances of the inner and outer ring width $\Delta B_s, \Delta T_s$	
Over	Up to	High	Low
0	20	0	-10
20	30	0	-25
30	40	0	-50

Unit: μm

Table 2.7 Tolerance of the inner ring width B and outer ring width T – CRBD, CRBE

Inner diameter d [mm]		Tolerances of the inner and outer ring width $\Delta B_s, \Delta T_s$			
		Inner ring: CRBD Inner and outer ring: CRBE		Outer ring: CRBD	
Over	Up to	High	Low	High	Low
0	30	0	-75	0	-100
30	50	0	-75	0	-100
50	80	0	-75	0	-100
80	120	0	-75	0	-100
120	150	0	-100	0	-120
150	180	0	-100	0	-120
180	250	0	-100	0	-120
250	315	0	-120	0	-150
315	400	0	-150	0	-200

Unit: μm

Crossed Roller Bearings

General information

Inner diameter d [mm]		Radial runout tolerance of inner ring K_{ia}			Axial runout tolerance of inner ring S_{ia}		
		P5	P4	P2	P5	P4	P2
Over	Up to	Max.	Max.	Max.	Max.	Max.	Max.
50	80	4	3	2	5	4	2
80	120	5	4	2	6	4	2
120	150	6	5	2	8	6	2
150	180	6	5	4	8	6	4
180	250	8	6	4	10	6	4
250	315	10	8	—	13	8	—
315	400	12	9	—	15	9	—

Unit: μm

Notes:

1. The CRBA series is available in the accuracy classes P5, P4 and P2.
2. The CRBC series is available in the accuracy classes P4 and P2.

Outer ring D [mm]		Radial runout tolerance of outer ring K_{ea}			Axial runout tolerance of outer ring S_{ea}		
		P5	P4	P2	P5	P4	P2
Over	Up to	Max.	Max.	Max.	Max.	Max.	Max.
50	80	6	4	3	8	4	3
80	120	8	5	4	9	5	4
120	150	9	6	4	10	6	4
150	180	10	6	4	11	6	4
180	250	12	8	6	12	8	6
250	315	14	9	6	14	8	6
315	400	15	10	6	15	10	6
400	500	18	12	—	18	12	—

Unit: μm

Notes:

1. The CRBB series is available in the accuracy classes P5, P4 and P2.
2. The CRBC series is available in the accuracy classes P4 and P2.

Model	Radial runout tolerance of inner ring K_{ia}		Axial runout tolerance of inner ring S_{ia}		Radial runout tolerance of outer ring K_{ea}		Axial runout tolerance of outer ring S_{ea}	
	P5	P4	P5	P4	P5	P4	P5	P4
	Max.	Max.	Max.	Max.	Max.	Max.	Max.	Max.
CRBD 02012	4	3	4	3	6	4	7	4
CRBD 03515	5	4	5	4	7	5	7	5
CRBD 05515	5	4	5	4	8	5	8	5
CRBD 08022	5	4	5	4	8	5	8	5
CRBD 09025	6	5	6	5	10	6	10	6
CRBD 11528	6	5	6	5	10	6	10	6
CRBD 16035	8	6	8	6	13	8	13	8

Unit: μm

Table 2.11 Rotational accuracy of the inner and the outer ring – CRBE

Model	Radial runout tolerance of inner ring K_{ia}		Axial runout tolerance of inner ring S_{ia}		Radial runout tolerance of outer ring K_{ea}		Axial runout tolerance of outer ring S_{ea}	
	P4	P2	P4	P2	P4	P2	P4	P2
	Max.	Max.	Max.	Max.	Max.	Max.	Max.	Max.
CRBE 02012	3	3	3	3	5	4	5	4
CRBE 03515	4	3	4	3	6	5	6	5
CRBE 05515	4	3	4	3	6	5	6	5
CRBE 08022	4	3	4	3	8	5	8	5
CRBE 09025	5	3	5	3	10	7	10	7
CRBE 11528	5	3	5	3	10	7	10	7
CRBE 16035	6	5	6	5	11	7	11	7
CRBE 21040	8	5	8	5	13	8	13	8

Unit: μm

Table 2.12 Preload

Nominal diameter d [mm]		Preload		Slight play	
		C8		C1	
Over	Up to	Min.	Max.	Min.	Max.
18	30	-8	0	—	—
30	50	-8	0	2	15
50	80	-10	0	2	20
80	120	-10	0	2	20
120	140	-10	0	2	20
140	160	-10	0	2	20
160	180	-10	0	2	20
180	200	-10	0	2	20
200	225	-10	0	2	20
225	250	-10	0	2	20
250	280	-15	0	2	25
280	315	-15	0	2	25
315	355	-15	0	2	25
355	400	-15	0	2	25
400	450	-20	0	2	25

Unit: μm

Crossed Roller Bearings

Design properties and selection

3. Design properties and selection

3.1 Selecting a crossed roller bearing

The choice of crossed roller bearing depends on the conditions of use.

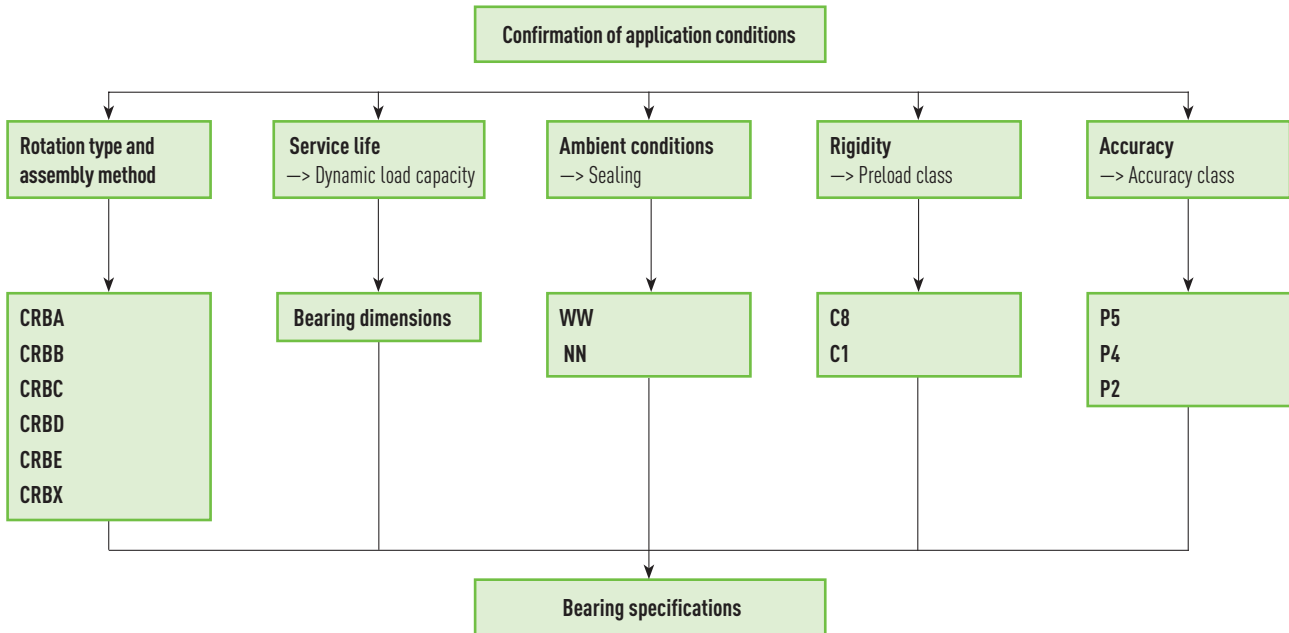

3.2 Formulae

3.2.1 Dynamic equivalent load

When radial and axial loads as well as torques are acting on the bearing, all loads can be collected in a single load acting on the centre of the bearing. This load is called the equivalent dynamic load and is calculated with the following formula [F 3.1]:

F 3.1

$$P = X \left(F_r + \frac{2M}{D_{pw}} \right) + Y F_a$$

where $X = 1, Y = 0.45$ for $\frac{F_a}{F_r + 2M/D_{pw}} \leq 1.5$

$X = 0.67, Y = 0.67$ for $\frac{F_a}{F_r + 2M/D_{pw}} > 1.5$

- P Dynamic equivalent load [N]
- F_r Radial load [N]
- F_a Axial load [N]
- M Torque [Nmm]
- X Radial load coefficient
- Y Axial load coefficient
- D_{pw} Roller's half-height diameter [mm]

3.2.2 Nominal lifetime

Formula F 3.2 can be used to calculate the nominal service life in millions of rotations. The nominal service life is equivalent to the number of rotations that 90 % of an adequately large number of bearings under constant loading and at constant speed can attain or exceed before the first symptoms of fatigue appear.

F 3.2

$$L = \left(\frac{C}{P} \right)^{\frac{10}{3}}$$

- L Nominal lifetime of bearing in 10^6 revolutions
- P Dynamic equivalent load [N]
- C Dynamic load rating [N]

3.2.3 Static equivalent load

The statically equivalent load P_0 is a calculated theoretical load. It exerts the same load on the centre of the contact site under the highest load between the rolling element and the track as the actual effect of the combined load.

F 3.3

$$P_0 = F_r + \frac{2M}{D_{pw}} + 0.44 F_a$$

P_0 Static equivalent load [N]
 F_r Radial load [N]
 F_a Axial load [N]
 M Torque [Nmm]
 D_{pw} Roller's half-height diameter [mm]

3.2.4 Static load safety factor

The static structural safety f_s is the ratio of the static load rating C_0 and the equivalent static load P_0 (F.3.4). The recommended static structural safety based on the operating conditions is given in Table 3.1:

F 3.4

$$f_s = \left(\frac{C_0}{P_0} \right)$$

f_s Static load safety factor
 C_0 Static load rating [N]
 P_0 Static equivalent load [N]

Table 3.1 Recommended static load safety factor

Operating conditions	Static load safety factor f_s
Standard operation	≥ 1.5
Bearing under vibrating load	≥ 2
High rotation and high accuracy	≥ 3

Crossed Roller Bearings

Design properties and selection

3.2.5 Example calculation of nominal service life and static structural safety

Bearing CRBA 15025 WW:

Inner diameter d	150 mm
Outer diameter D	210 mm
Roller's half-height diameter D_{pw}	180 mm
Dynamic load rating C	73,100 N
Static load rating C_0	131,900 N
W_1	800 N
W_2	2,200 N
Radial load F_r	3,000 N
L	800 mm

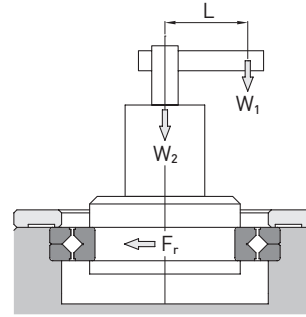

Calculation:

Radial load:	$F_r = 3,000 \text{ N}$
Axial load:	$F_a = W_1 + W_2 = 800 \text{ N} + 2,200 \text{ N} = 3,000 \text{ N}$
Torque:	$M = W_1 \times L = 800 \text{ N} \times 800 \text{ mm} = 640,000 \text{ Nmm}$
Roller's half-height diameter:	$D_{pw} = (d + D)/2 = (150 \text{ mm} + 210 \text{ mm})/2 = 180 \text{ mm}$

$$\frac{F_a}{F_r + 2M/D_{pw}} = \frac{3,000}{3,000 + 2 \times 640,000/180} \approx 0.297 < 1.5$$

Radial load coefficient $X = 1$; axial load coefficient $Y = 0.45$

Dynamic equivalent radial load:

$$P = X \left(F_r + \frac{2M}{D_{pw}} \right) + Y F_a = 1 \times \left(3,000 + \frac{2 \times 640,000}{180} \right) + 0.45 \times 3,000 \approx 11,461 \text{ N}$$

Static equivalent radial load:

$$P_0 = F_r + \frac{2M}{D_{pw}} + 0.44 F_a = 3,000 + \frac{2 \times 640,000}{180} + 0.44 \times 3,000 \approx 11,431 \text{ N}$$

Nominal lifetime:

$$L = \left(\frac{C}{P} \right)^{\frac{10}{3}} = \left(\frac{73,100}{11,461} \right)^{\frac{10}{3}} \approx 481 (\times 10^6 \text{ revolutions})$$

Static load safety factor:

$$f_s = \left(\frac{C_0}{P_0} \right) = \frac{131,900}{11,431} \approx 11.5$$

3.3 Combined fits

Preload	Operating conditions		Recommended combined fits	
			∅ Shaft	∅ Housing bore
C8	Rotation loading on inner ring	Normal loading	h5	H6
		Strong vibrations and impacts		
	Rotation loading on outer ring	Normal loading	g5	JS6 or J6
		Strong vibrations and impacts		
C1	Rotation loading on inner ring	Normal loading	js5 or j5	H6
		Strong vibrations and impacts	k5	JS6 or J6
	Rotation loading on outer ring	Normal loading	g5	JS6 or J6
		Strong vibrations and impacts	h5	K6

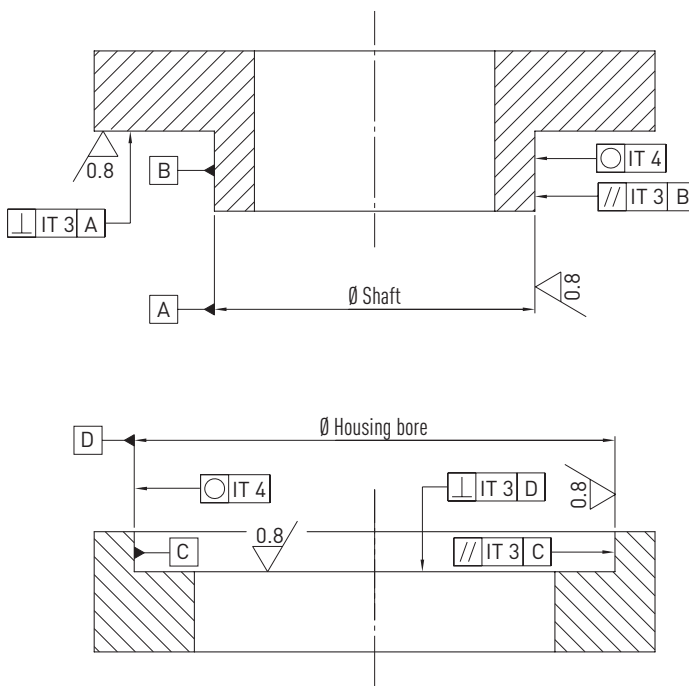

3.4 Securing and designing the bearing seat and mounting flange

The bearing seat and mounting flange serve to secure and preload the bearing. Crossed roller bearings are designed with thin walls, so the seat's rigidity and mounting flange are assigned an important role. If models with a split outer ring are used and the thicknesses of the bearing seat and mounting flange walls is inadequate, this can lead to an uneven loading over the inner and outer ring. This can cause deformation in the housing, leading to a reduced service life and uneven running. This can be eliminated when the bearing seat and mounting flange are designed as follows:

F 3.5

$$T > \frac{D-d}{2} \times 0.6$$

- T Wall thickness of the bearing seat [mm]
- D Outer diameter of bearing [mm]
- d Inner diameter of bearing [mm]

Formula F 3.5 applies to the design of steel bearing seats. If another material is used, the bearing seat must be adjusted to its properties.

Crossed Roller Bearings

Design properties and selection

In addition, we recommend designing the bearing seat with threaded holes. If the bearing is to be removed from its seat, the screw can be used to detach it without causing it any damage.

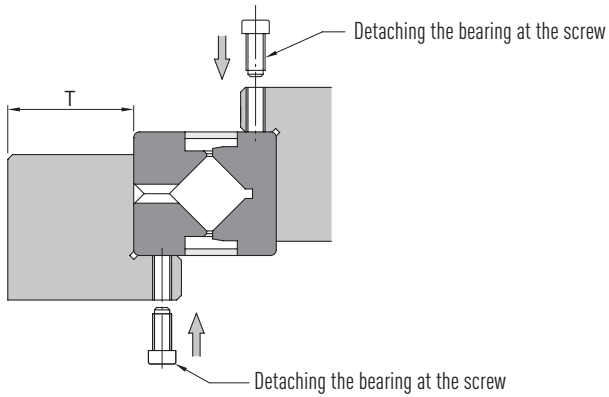

Mounting flange: The following formula can be used to calculate the height and the depth of the mounting flange groove.

F 3.6 $E = B \times 0.5 \text{ to } B \times 1.2$
 $S = 0.5 \text{ mm}$

- E Height of the mounting flange
- S Groove depth
- H Height of the bearing seat
- B Bearing height

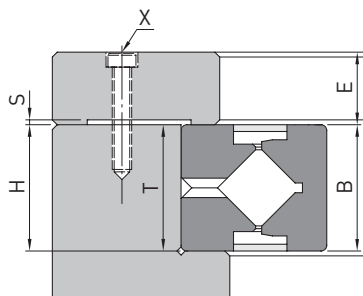

Table 3.3 Height of the bearing seat for inner ring B and outer ring T – CRBA, CRBB, CRBC

B, T [mm]	H [mm]
16	16 ^{-0.005} _{-0.025}
20	20 ^{-0.020} _{-0.050}
25	25 ^{-0.020} _{-0.060}
30	30 ^{-0.020} _{-0.060}
35	35 ^{-0.040} _{-0.100}
40	40 ^{-0.040} _{-0.100}

Table 3.4 Number and size of the mounting bolts X on the mounting flange

Outer ring diameter D [mm]	Number of bolts	Bolt size
over 100	≥ 8	M3 – M5
100 – 200	≥ 12	M4 – M8
200 – 500	≥ 16	M5 – M12
over 500	≥ 24	over M6

Unit: mm

Table 3.5 Tightening torques for mounting bolts¹⁾

Mounting bolt	Tightening torque	Mounting bolt	Tightening torque
M3	2	M10	70
M4	4	M12	120
M5	9	M16	200
M6	14	M20	390
M8	30	M22	530

Unit: Nm

¹⁾ For bearing seats of medium hard steel

Crossed Roller Bearings

Design properties and selection

3.5 Assembly

When mounting the crossed roller bearing, observe the following sequence:

1. Before mounting, check all parts: Clean the bearing housing, the main axis, and other parts so that they are free of dirt and grease.
2. Place the bearing in its housing and on the main axis: Owing to the tolerances, you should hold the bearing horizontal when you insert it into the housing or axis. If mounting proves difficult, you may use a rubber hammer to strike the bearing lightly and uniformly into the housing or axis. A changing sound indicates that the bearing has reached its seat. Press fit parts can be heated or cooled to facilitate their mounting. In these cases, the bearing temperature may not exceed 80 °C. In addition, note the force applied to press in the bearing: too large a force may damage the bearing. If the inner or outer ring of split bearings is not centred, their screws can be loosened slightly.
3. Fitting the mounting flange: Place the mounting flange on the bearing, and align the flange's and housing's holes so that they can be secured with the screws. Tighten the screws in a crosswise fashion as shown in the figure.

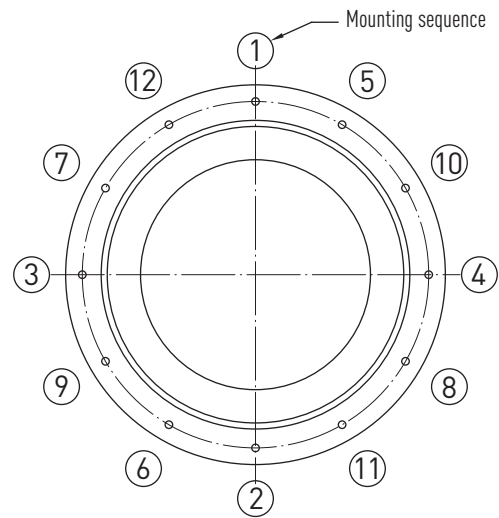

3.6 Further information

3.6.1 Lubrication

1. The bases of all crossed roller bearings are greased with HIWIN G05 (lithium soap grease). So the bearings can be installed directly after delivery. Reduced lubrication increases the frictional resistance, leading to a reduction in service life. Open bearings (without seal) should be relubricated regularly every one to six months. The lubrication intervals depend on the intensity of use. Important: After lubricating, turn the bearing to distribute the lubricant evenly inside the bearing.
2. There must be no mixing of different lubricants.
3. A special lubricant is required for special applications like clean rooms, vacuum, high vibrations, temperatures < 10 °C or > 80 °C, etc. Please contact HIWIN.

3.6.2 Safety notices for operation

1. The bearing's normal operating temperature is between 10 °C and 80 °C.
2. Foreign bodies entering inside the bearing can cause damage to the track and rollers. In extreme cases, the bearing may fail. Foreign bodies must therefore be prevented from entering the bearing.
3. If, however, foreign bodies should enter inside the bearing, you must first clean the bearing and then refill it with lubricant.
4. The split bearing's bolt and nut may not be removed. When mounting, do not apply any force to the bolt and nut.

4. Crossed roller bearings: series

4.1 CRBA

Series with split outer ring

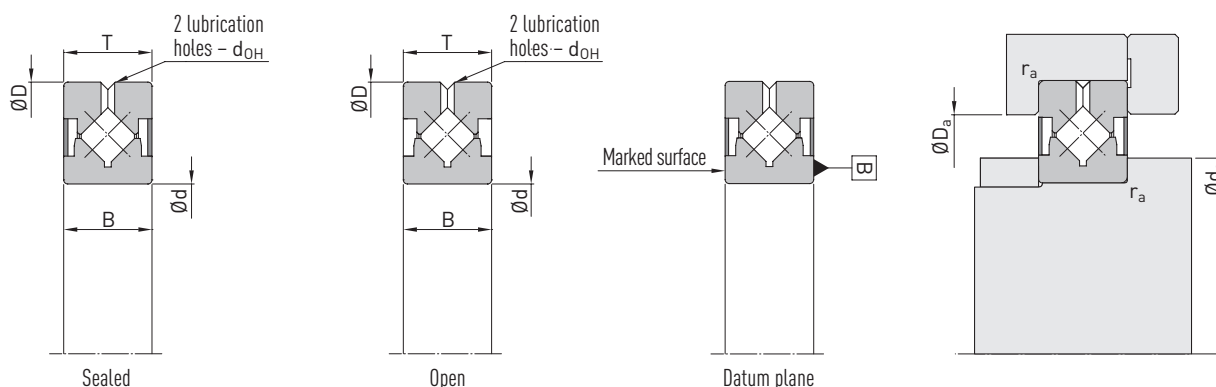

Table 4.1 CRBA specifications

Article number	Dimensions [mm]			Lubrication holes d_{OH}	Installation dim. [mm]			Load ratings [kN]				Max. idle torque [Nm] ²⁾	Max. speed [rpm]		Weight [kg]
	d ¹⁾	D ¹⁾	Width B, T		d_a	D_a	r_a (max)	Dyn. load rating C_{dyn}		Stat. load rating C_0			Grease	Oil	
								Radial	Axial	Radial	Axial				
CRBA 08016	80	120	16	$\varnothing 2.5$	92	109	0.6	30.2	67	44.8	102	0.63	600	800	0.70
CRBA 09016	90	130	16	$\varnothing 2.5$	104	120	1.0	30.8	68	47.4	108	0.70	540	720	0.80
CRBA 09020	90	140	20	$\varnothing 2.5$	104	120	1.0	39.7	88	60.2	136	0.95	520	700	1.20
CRBA 10016	100	140	16	$\varnothing 2.5$	112	129	1.0	32.5	72	52.3	118	0.80	500	660	0.84
CRBA 10020	100	150	20	$\varnothing 2.5$	117	132	1.0	40.4	90	63.6	144	1.05	480	640	1.38
CRBA 11020	110	160	20	$\varnothing 2.5$	126	143	1.0	42.7	95	70.2	159	1.20	440	590	1.50
CRBA 12016	120	150	16	$\varnothing 2.5$	126	143	1.0	28.1	62	50.3	114	0.75	440	590	0.74
CRBA 12020	120	170	20	$\varnothing 2.5$	136	153	1.5	44.9	100	76.9	175	1.30	410	550	2.10
CRBA 12025	120	180	25	$\varnothing 2.5$	138	158	1.5	66.3	147	109.0	246	2.02	400	530	2.60
CRBA 13025	130	190	25	$\varnothing 2.5$	148	168	1.5	67.8	150	114.8	261	2.20	375	500	2.70
CRBA 14025	140	200	25	$\varnothing 2.5$	161	178	1.5	69.5	154	120.6	274	2.40	350	470	2.84
CRBA 15025	150	210	25	$\varnothing 2.5$	168	188	1.5	73.1	162	131.9	300	2.70	330	440	3.60
CRBA 15030	150	230	30	$\varnothing 3.0$	181	198	1.5	114.3	254	187.3	425	4.40	310	420	5.26
CRBA 16025	160	220	25	$\varnothing 2.5$	181	198	1.5	74.5	165	137.7	313	2.90	310	420	3.32
CRBA 17020	170	220	20	$\varnothing 2.5$	183	203	1.5	52.3	116	103.6	235	2.10	300	410	2.12
CRBA 18025	180	240	25	$\varnothing 2.5$	198	218	1.5	79.6	177	154.8	352	3.40	285	380	3.54
CRBA 19025	190	240	25	$\varnothing 2.5$	203	223	1.0	54.5	121	113.6	258	2.40	280	370	2.90
CRBA 20025	200	260	25	$\varnothing 2.5$	218	238	2.0	82.3	183	166.4	378	3.85	260	340	4.16
CRBA 20030	200	280	30	$\varnothing 3.0$	231	248	2.0	122.9	273	242.0	550	6.40	250	330	4.12
CRBA 20035	200	295	35	$\varnothing 3.0$	238	258	2.0	155.9	346	277.4	630	7.40	240	320	9.58
CRBA 22025	220	280	25	$\varnothing 2.5$	237	259	2.0	86.3	192	183.5	417	4.40	240	320	4.14
CRBA 24025	240	300	25	$\varnothing 2.5$	257	279	2.0	90.5	201	200.6	456	5.00	220	290	4.50
CRBA 25025	250	310	25	$\varnothing 2.5$	267	289	2.0	91.6	203	206.4	469	5.20	210	285	4.64
CRBA 25030	250	330	30	$\square 5 \times 2$	280	299	2.0	142.0	315	286.2	650	8.40	200	275	8.20
CRBA 25040	250	355	40	$\varnothing 4.0$	289	311	2.0	207.0	460	391.8	890	12.80	200	260	14.40
CRBA 30025	300	360	25	$\varnothing 2.5$	317	339	2.5	100.6	223	246.5	560	7.00	180	240	5.46
CRBA 30035	300	395	35	$\varnothing 3.0$	337	359	2.5	191.6	426	407.8	927	13.50	170	230	5.80
CRBA 30040	300	405	40	$\varnothing 4.0$	339	361	2.5	227.0	504	465.8	1,058	16.50	170	220	17.00
CRBA 40035	400	480	35	$\varnothing 3.0$	426	447	2.5	219.4	487	523.9	1,190	20.00	135	180	13.86

¹⁾ d = Inner diameter; D = Outer diameter

²⁾ Measured at 30 rpm with grease filling (G05)

Note: The load ratings correspond to the standard ISO76/ISO281

Crossed Roller Bearings

CRBB

4.2 CRBB

Series with split inner ring.

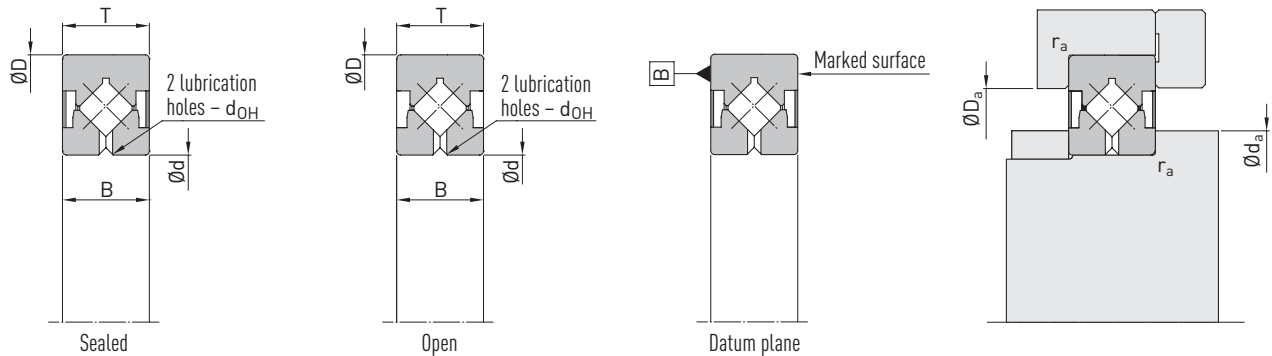

Table 4.2 CRBB specifications

Article number	Dimensions [mm]			Oil holes d _{OH}	Installation dim. [mm]			Load ratings [kN]				Max. idle torque [Nm] ²⁾	Max. speed [rpm]		Weight [kg]
	d ¹⁾	D ¹⁾	Width B, T		d _a	D _a	r _a (max)	Dyn. load rating C _{dyn}		Stat. load rating C ₀			Grease	Oil	
								Radial	Axial	Radial	Axial				
CRBB 08016	80	120	16	Ø2.5	92	109	0.6	30.2	102	44.8	67	0.63	600	800	0.70
CRBB 09016	90	130	16	Ø2.5	104	120	1.0	30.8	108	47.4	68	0.70	540	720	0.80
CRBB 09020	90	140	20	Ø2.5	104	120	1.0	39.7	136	60.2	88	0.95	520	700	1.20
CRBB 10016	100	140	16	Ø2.5	112	129	1.0	32.5	118	52.3	72	0.80	500	660	0.84
CRBB 10020	100	150	20	Ø2.5	117	132	1.0	40.4	144	63.6	90	1.05	480	640	1.38
CRBB 11020	110	160	20	Ø2.5	126	143	1.0	42.7	159	70.2	95	1.20	440	590	1.50
CRBB 12016	120	150	16	Ø2.5	126	143	1.0	28.1	114	50.3	62	0.75	440	590	0.74
CRBB 12020	120	170	20	Ø2.5	136	153	1.5	44.9	175	76.9	100	1.30	410	550	2.10
CRBB 12025	120	180	25	Ø2.5	138	158	1.5	66.3	246	109.0	147	2.02	400	530	2.60
CRBB 13025	130	190	25	Ø2.5	148	168	1.5	67.8	261	114.8	150	2.20	375	500	2.70
CRBB 14025	140	200	25	Ø2.5	161	178	1.5	69.5	274	120.6	154	2.40	350	470	2.84
CRBB 15025	150	210	25	Ø2.5	168	188	1.5	73.1	162	131.9	300	2.70	330	440	3.60
CRBB 15030	150	230	30	Ø3.0	181	198	1.5	114.3	254	187.3	425	4.40	310	420	5.26
CRBB 16025	160	220	25	Ø2.5	181	198	1.5	74.5	165	137.7	313	2.90	310	420	3.32
CRBB 17020	170	220	20	Ø2.5	183	203	1.5	52.3	116	103.6	235	2.10	300	410	2.12
CRBB 18025	180	240	25	Ø2.5	198	218	1.5	79.6	177	154.8	352	3.40	285	380	3.54
CRBB 19025	190	240	25	Ø2.5	203	223	1.0	54.5	121	113.6	258	2.40	280	370	2.90
CRBB 20025	200	260	25	Ø2.5	218	238	2.0	82.3	183	166.4	378	3.85	260	340	4.16
CRBB 20030	200	280	30	Ø3.0	231	248	2.0	122.9	273	242.0	550	6.40	250	330	4.12
CRBB 20035	200	295	35	Ø3.0	238	258	2.0	155.9	346	277.4	630	7.40	240	320	9.58
CRBB 22025	220	280	25	Ø2.5	237	259	2.0	86.3	192	183.5	417	4.40	240	320	4.14
CRBB 24025	240	300	25	Ø2.5	257	279	2.0	90.5	201	200.6	456	5.00	220	290	4.50
CRBB 25025	250	310	25	Ø2.5	267	289	2.0	91.6	203	206.4	469	5.20	210	285	4.64
CRBB 25030	250	330	30	Ø3.0	280	299	2.0	142.0	315	286.2	650	8.40	200	275	8.20
CRBB 25040	250	355	40	Ø4.0	289	311	2.0	207.0	460	391.8	890	12.80	200	260	14.40
CRBB 30025	300	360	25	Ø2.5	317	339	2.5	100.6	223	246.5	560	7.00	180	240	5.46
CRBB 30035	300	395	35	Ø3.0	337	359	2.5	191.6	426	407.8	927	13.50	170	230	5.80
CRBB 30040	300	405	40	Ø4.0	339	361	2.5	227.0	504	465.8	1,058	16.50	170	220	17.00

¹⁾ d = Inner diameter; D = Outer diameter

²⁾ Measured at 30 rpm with grease filling (G05)

Note: The load ratings correspond to the standard ISO76/ISO281

4.3 CRBC

Series with solid inner and outer ring.

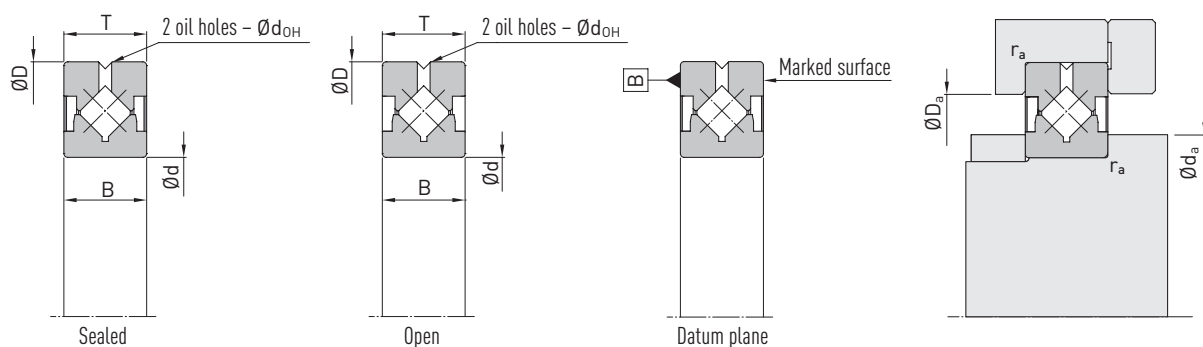

Table 4.3 CRBC specifications

Article number	Dimensions [mm]			Oil holes d_{OH}	Installation dim. [mm]			Load ratings [kN]				Max. idle torque [Nm] ²⁾	Max. speed [rpm]		Weight [kg]
	d ¹⁾	D ¹⁾	Width B, T		d_a	D_a	r_a (max)	Dyn. load rating C_{dyn}		Stat. load rating C_0			Grease	Oil	
								Radial	Axial	Radial	Axial				
CRBC 08016	80	120	16	2.5	92	109	0.6	30.2	67.0	44.8	102	0.63	600	800	0.70
CRBC 09016	90	130	16	2.5	104	120	1.0	30.8	68.0	47.4	108	0.70	540	720	0.80
CRBC 09020	90	140	20	2.5	104	120	1.0	39.7	88.0	60.2	136	0.95	520	700	1.20
CRBC 10016	100	140	16	2.5	112	129	1.0	32.5	72.0	52.3	118	0.80	500	660	0.84
CRBC 10020	100	150	20	2.5	117	132	1.0	40.4	90.0	63.6	144	1.05	480	640	1.38
CRBC 11020	110	160	20	2.5	126	143	1.0	42.7	95.0	70.2	159	1.20	440	590	1.50
CRBC 12016	120	150	16	2.5	126	143	1.0	28.1	62.0	50.3	114	0.75	440	590	0.74
CRBC 12020	120	170	20	2.5	136	153	1.5	44.9	100.0	76.9	175	1.30	410	550	2.10
CRBC 12025	120	180	25	2.5	138	158	1.5	66.3	147.0	109.0	246	2.02	400	530	2.60
CRBC 13025	130	190	25	2.5	148	168	1.5	67.8	150.0	114.8	261	2.20	375	500	2.70
CRBC 14025	140	200	25	2.5	161	178	1.5	69.5	154.0	120.6	274	2.40	350	470	2.84
CRBC 15025	150	210	25	2.5	168	188	1.5	73.1	162.0	131.9	300	2.70	330	440	3.60
CRBC 40035	400	480	35	3.0	426	447	2.5	219.4	487.0	523.9	1,190	20.00	135	180	13.86

¹⁾ d = Inner diameter; D = Outer diameter

²⁾ Measured at 30 rpm with grease filling (G05)

Note: The load ratings correspond to the standard ISO76/ISO281

Crossed Roller Bearings

CRBD

4.4 CRBD

Series with split outer ring and mounting flange.

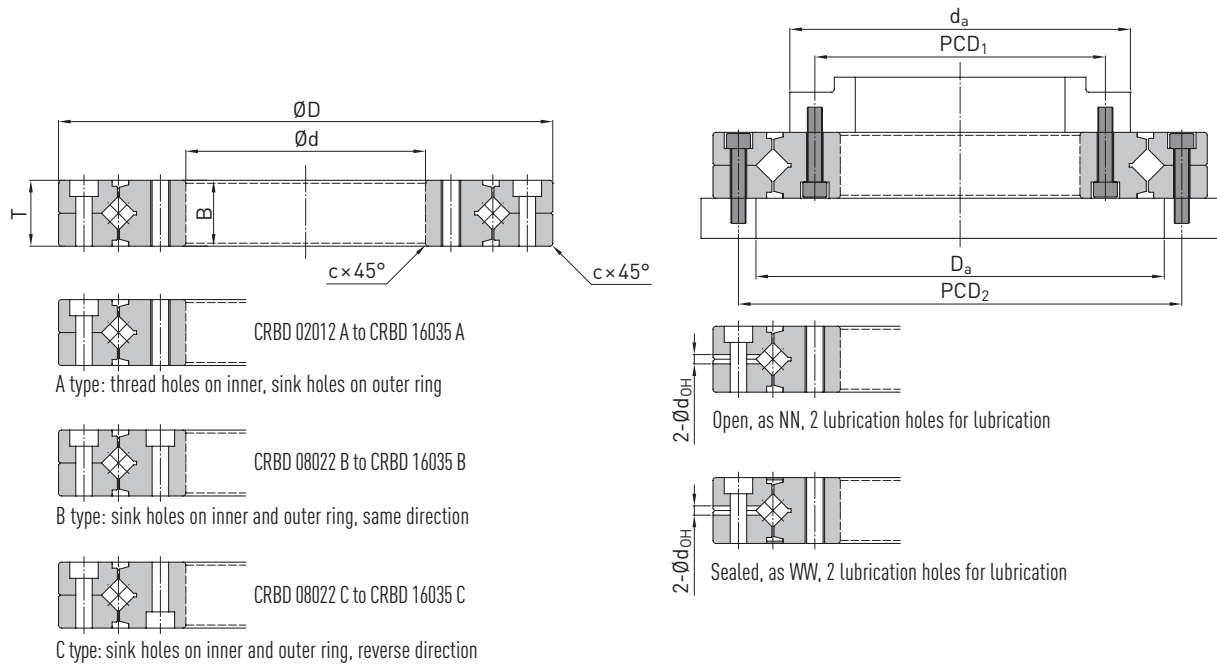

Table 4.4 CRBD specifications

Article number	Dimensions [mm]					Inst. dim. [mm]		Load ratings [kN]				Mounting holes [mm]				Max. $T_d^{1)}$ [Nm] ²⁾	Max. speed [rpm]		Mass [kg]
	d ¹⁾	D ¹⁾	B, T ¹⁾	c _{min}	d _{OH} ¹⁾	d _a	D _a	C _{dyn} ¹⁾		C ₀ ¹⁾		Inner rings		Outer rings			Grease	Oil	
								Rad.	Ax.	Rad.	Ax.	PCD ₁	Mounting holes	PCD ₂	Mounting holes				
CRBD 02012 A ³⁾	20	70	12	0.6	3	35	47	8.3	18	9.2	20.8	28	6×M3	57	6×Ø6.5×3.3U Ø3.4	0.075	1,470	1,970	0.30
CRBD 03515 A	35	95	15	0.6	3	57	73	18.9	42	23.4	53.0	45	8×M4	83	8×Ø8×4.4U Ø4.5	0.25	930	1,250	0.65
CRBD 05515 A	55	120	15	0.6	3	77	92	21.7	48	30.6	69.0	65	8×M5	105	8×Ø9.5×5.4U Ø5.5	0.4	710	950	0.97
CRBD 08022 A	80	165	22	1.0	3	117	132	40.4	90	63.6	144.0	97	10×M5	148	10×Ø9.5×5.4U Ø5.5	1.0	480	640	2.56
CRBD 08022 B													10×Ø9.5×5.4U Ø5.5						
CRBD 08022 C													10×Ø9.5×5.4U Ø5.5						
CRBD 09025 A	90	210	25	1.5	3	139	157	46.0	102	80.2	182.0	112	12×M8	187	12×Ø14×8.6U Ø9	1.5	400	530	5.04
CRBD 09025 B													12×Ø14×8.6U Ø9						
CRBD 09025 C													12×Ø14×8.6U Ø9						
CRBD 11528 A	115	240	28	1.5	3	168	188	73.1	162	131.9	300.0	139	12×M8	217	12×Ø14×8.6U Ø9	2.7	330	440	6.76
CRBD 11528 B													12×Ø14×8.6U Ø9						
CRBD 11528 C													12×Ø14×8.6U Ø9						
CRBD 16035 A	160	295	35	2.0	6	218	238	102.0	226	192.3	437.0	184	12×M10	270	12×Ø17.5×10.8U Ø11	4.8	260	340	11.98
CRBD 16035 B													12×Ø17.5×10.8U Ø11						
CRBD 16035 C													12×Ø17.5×10.8U Ø11						

¹⁾ d = Inner diameter; D = Outer diameter; d_{OH} = Lubrication hole diameter; B, T = width; T_d = Idle torque

C_{dyn} = Dynamic load rating; C₀ = Static load rating

²⁾ Measured at 30 rpm with grease filling (G05)

³⁾ CRBD 02012 A only available in C8

Note: The load ratings correspond to the standard ISO76/ISO281

4.5 CRBE

Series with solid inner and outer ring and mounting flange.

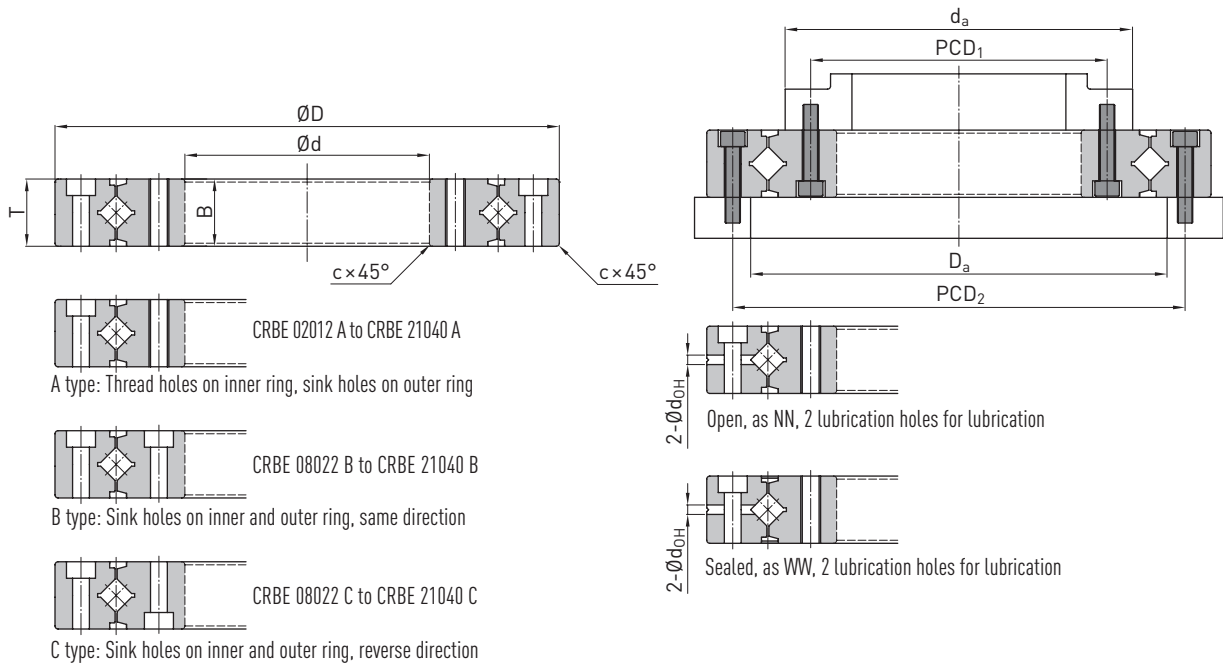

Table 4.5 CRBE specifications

Article number	Dimensions [mm]					Inst. dim. [mm]		Load ratings [kN]				Mounting holes [mm]				Max. T_d ¹⁾ [Nm] ²⁾	Max. speed [rpm]		Mass [kg]
	d ¹⁾	D ¹⁾	B, T ¹⁾	c _{min}	d _{OH} ¹⁾	d _a	D _a	C _{dyn} ¹⁾		C ₀ ¹⁾		Inner rings		Outer rings			Grease	Oil	
								Rad.	Ax.	Rad.	Ax.	PCD ₁	Mounting holes	PCD ₂	Mounting holes				
CRBE 02012 A ³⁾⁴⁾	20	70	12	0.6	3	35	47	8.3	18	9.2	20.8	28	6×M3	57	6×Ø6.5×3.3U Ø3.4	0.075	1,470	1,970	0.30
CRBE 03515 A ³⁾	35	95	15	0.6	3	57	73	18.9	42	23.4	53.0	45	8×M4	83	8×Ø8×4.4U Ø4.5	0.25	930	1,250	0.65
CRBE 05515 A ³⁾	55	120	15	0.6	3	77	92	21.7	48	30.6	69.0	65	8×M5	105	8×Ø9.5×5.4U Ø5.5	0.4	710	950	0.97
CRBE 08022 A ³⁾	80	165	22	1.0	3	117	132	40.4	90	63.6	144.0	97	10×M5	148	10×Ø9.5×5.4U Ø5.5	1.0	480	640	2.56
CRBE 08022 B													10×Ø9.5×5.4U Ø5.5						
CRBE 08022 C													10×Ø9.5×5.4U Ø5.5						
CRBE 09025 A	90	210	25	1.5	3	139	157	46.0	102	80.2	182.0	112	12×M8	187	12×Ø14×8.6U Ø9	1.5	400	530	5.04
CRBE 09025 B													12×Ø14×8.6U Ø9						
CRBE 09025 C													12×Ø14×8.6U Ø9						
CRBE 11528 A	115	240	28	1.5	3	168	188	73.1	162	131.9	300.0	139	12×M8	217	12×Ø14×8.6U Ø9	2.7	330	440	6.76
CRBE 11528 B													12×Ø14×8.6U Ø9						
CRBE 11528 C													12×Ø14×8.6U Ø9						
CRBE 16035 A	160	295	35	2.0	6	218	238	102.0	226	192.3	437.0	184	12×M10	270	12×Ø17.5×10.8U Ø11	4.8	260	340	11.98
CRBE 16035 B													12×Ø17.5×10.8U Ø11						
CRBE 16035 C													12×Ø17.5×10.8U Ø11						
CRBE 21040 A	210	380	40	2.5	6	277	299	142.0	315	286.2	650.0	240	16×M12	350	16×Ø20×13U Ø14	8.0	200	275	21.66
CRBE 21040 B													16×Ø20×13U Ø14						
CRBE 21040 C													16×Ø20×13U Ø14						

¹⁾ d = Inner diameter; D = Outer diameter; d_{OH} = Lubrication hole diameter; B, T = width; T_d = Idle torque; C_{dyn} = Dynamic load rating; C₀ = Static load rating

²⁾ Measured at 30 rpm with grease filling (G05) ³⁾ Preferred type in C8 and P4 with short delivery time ⁴⁾ CRBE 02012 A only available in C8

Note: The load ratings correspond to the standard ISO76/ISO281

Crossed Roller Bearings

Special crossed roller bearings CRBX

5. Special crossed roller bearings CRBX

The standardised crossed roller bearings presented in this catalogue can be used in a wide range of applications. For custom solutions tailored specifically to your requirements, our application engineers will be pleased to help you work out your optimal solution. The following examples include the CRBX crossed roller bearing that have also been installed in the HIWIN rotary tables TMS3 and TMS7.

Properties:

- Preloaded
- High rigidity
- Axial runout 0.01 mm

Article number	Dimensions [mm]		Load ratings [kN]				Max. idle torque [Nm] ²⁾	Max. speed [rpm]		Used in
	D ¹⁾	d ¹⁾	Dyn. load rating C _{dyn}		Stat. load rating C ₀			Grease	Oil	
			Radial	Axial	Radial	Axial				
8-18-0029	193	100	64.2	95.82	103.5	235.23	2.60	400	540	TMS3
8-18-0030	291	160	85.7	127.91	177.7	403.86	1.88	250	335	TMS7

¹⁾ d = Inner diameter; D = Outer diameter

²⁾ Measured at 30 rpm with grease filling (G02)

5.1 Dimensions

5.1.1 Dimensions of article 8-18-0029 (CRBX10045NNC8P5)

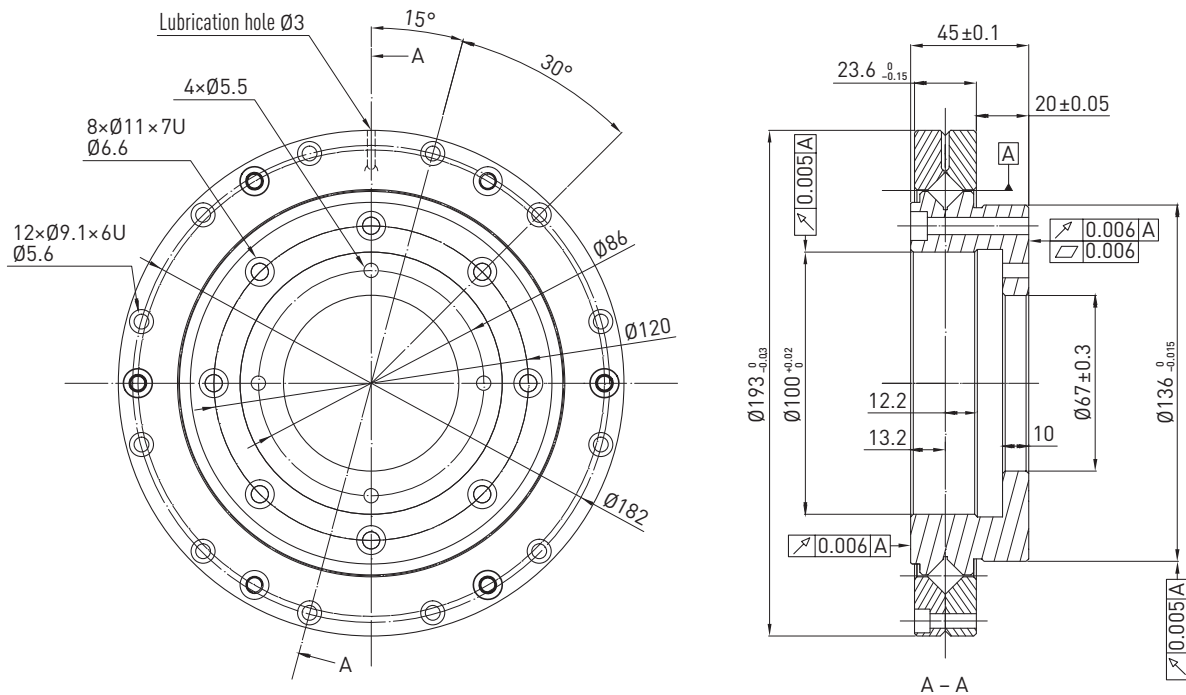

5.1.2 Dimensions of article 8-18-0030 (CRBX17049NNC8P5)

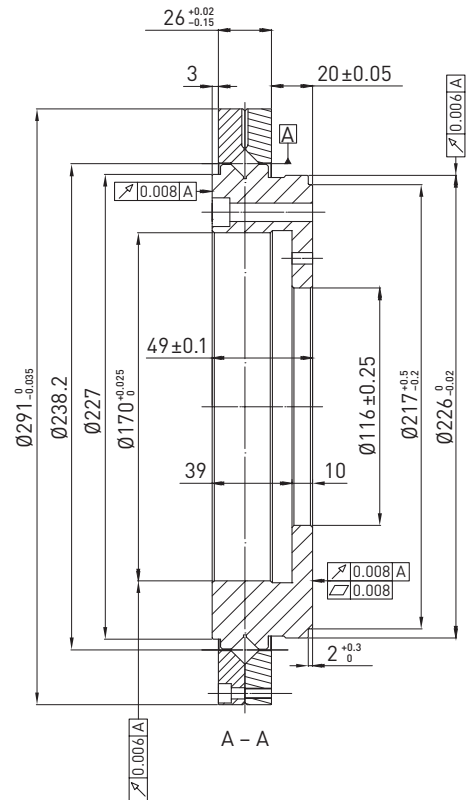
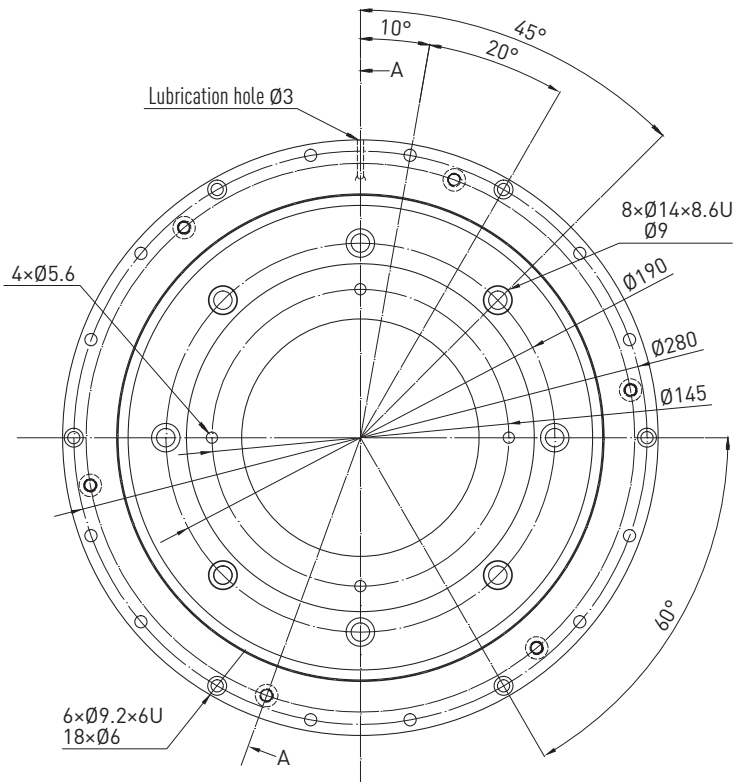

We live motion.

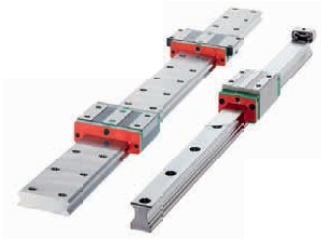

Linear Guideways



Ballscrews

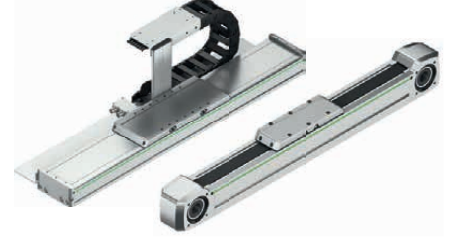

Linear Axes



Linear Axis Systems



Torque Motors



Robots



Linear Motor Components



Rotary Tables



Drives & Servo Motors

