

ECV9092 Model C€

- A.C. motor, flange B5 - CE
 - Worm gearbox
 - Acme lead screw or ballscrew (VRS) (**)
 - Chrome plated steel push rod
 - Grease Lubricated
 - IP 65, tested according to rule CEI EN 60529
NB: Only for brake motors Standard IP54, IP65 on request
 - Working temperature range -10 C°+60 C°
 - Intermittent duty S3 30% (5 min) a 30°C (*)
 - Integrated Limit switches on request
 - Potentiometer and encoder on request
- (*) For any special duty please contact our technical dept.
(**) Contact our technical dept.

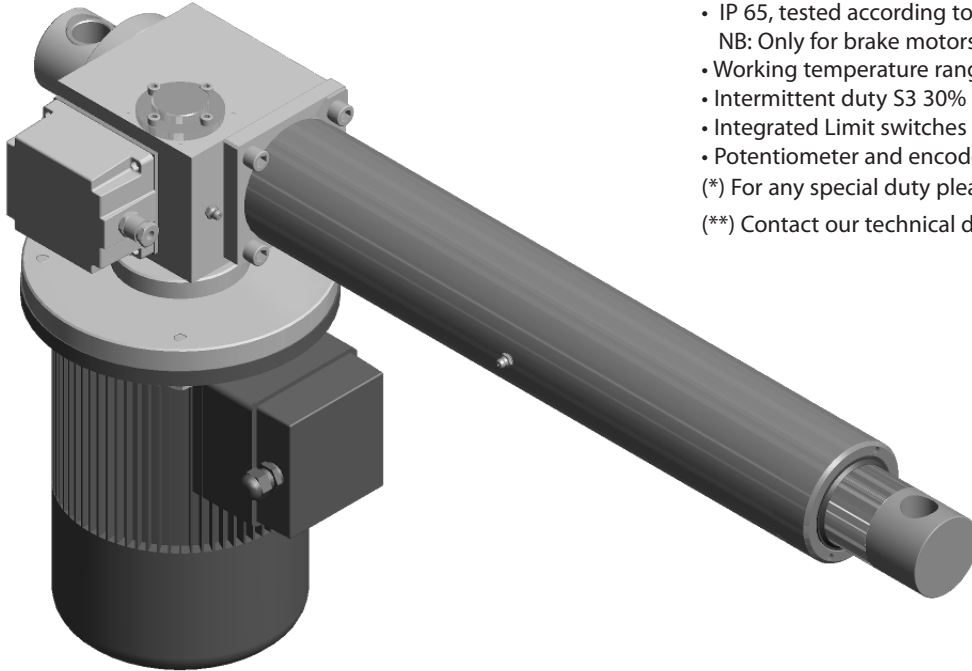

ECV9092 (Vac 3-phase)

<i>Fmax</i> (N)	<i>Speed</i> (mm/s)	<i>Version</i>	<i>Motor size</i>	<i>Motor power</i> (KW)	<i>Motor speed</i> (rpm)
* 15000	45	M01	IEC100	0.09	1400
25000	24	M02	IEC100	0.09	1400
40000	10	M03	IEC100	0.09	1400
40000	5	M04	IEC90	0.09	1400

With single-phase motors type M (see motor choice guideline in paragraph ACCESSORIES) performances are 20% lower than the three-phase motor.

* When speed is more than 40 mm/s and/or strokes longer than 350mm, check STROKE SETUP section; BRAKEMOTOR IS RECOMMENDED

BEFORE OPERATING ACTUATOR MAKE SURE YOU READ AND UNDERSTOOD BASIC OPERATIONAL INSTRUCTIONS SHOWN ON USERMANUALS, AVAILABLE FROM WEBSITE.

THIS DOCUMENT DISPLAYS MOST TYPICAL STANDARD FEATURES AND SETUPS: CONTACT OUR OFFICES FOR MORE.

ACTUATOR SHALL NOT COME TO **MECHANICAL STROKE-END**, TO **AVOID FAILURES**.

CONSIDER MECVEL'S LIMITSWITCHES (MODEL AV3-F or AV3-FCM) OR PUT THEM ON MACHINE/FRAME.



MecVel reserves the right to change products information and/or features without notice; all data contained in this catalogue are purely indicative and not binding for the company.

ECV9092 Version with limitswitches

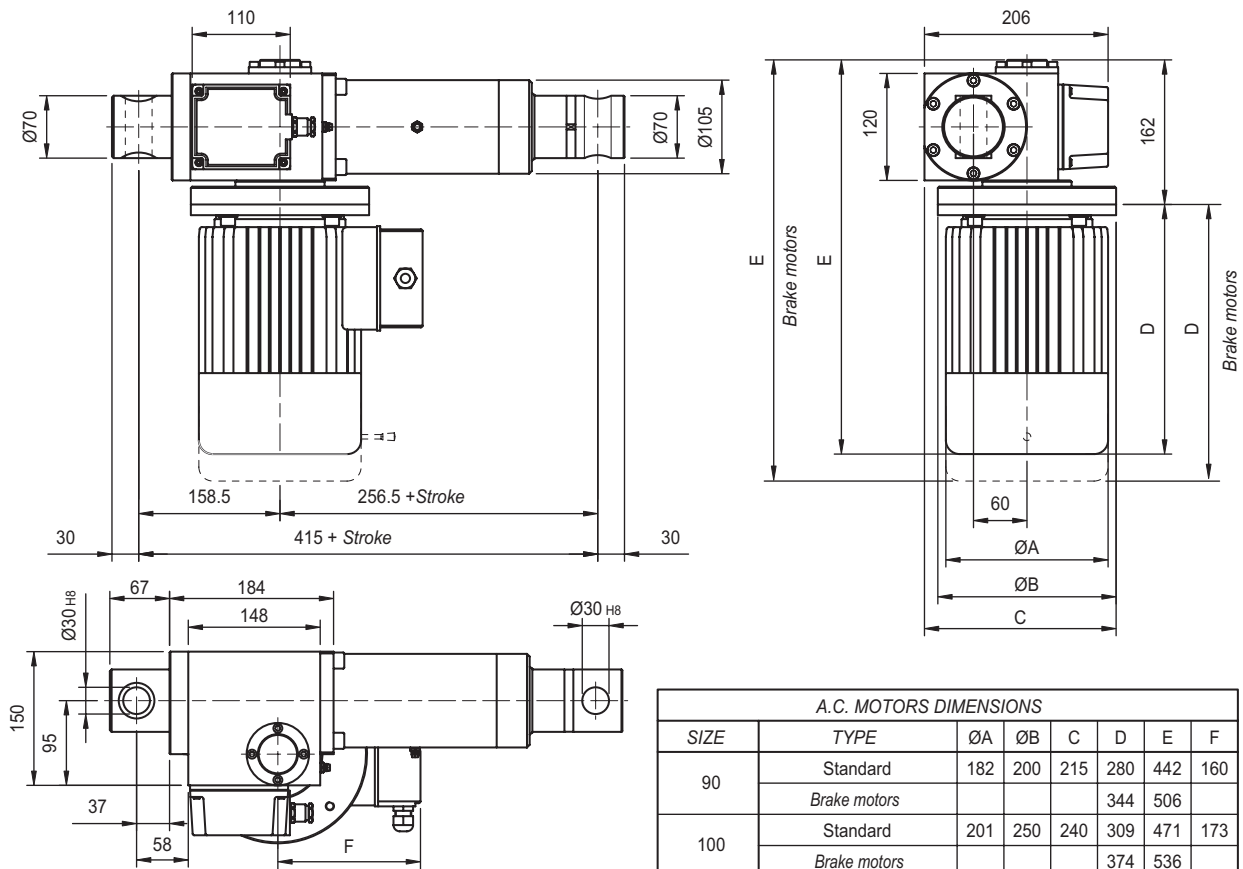

REAR ENDS

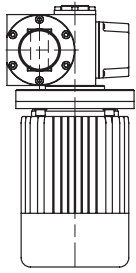

P1 Standard

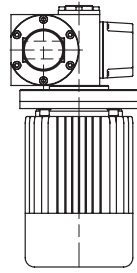

P2 Rotated 90°

E-BOX POSITION

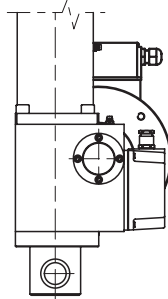

1 Standard

MOTOR AND LIMIT SWITCHES POSITION

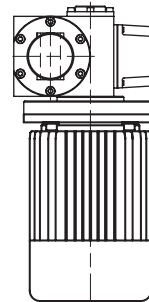

M0 (Standard)

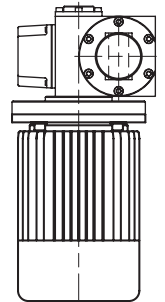

M1 (Sx)

STROKE SETUP: Useful tips for handling stroke and avoid run-on-block collision.

When stroke is more than 350 mm, add 50 mm extra-stroke as guidance, and put corresponding value in ordering-key.

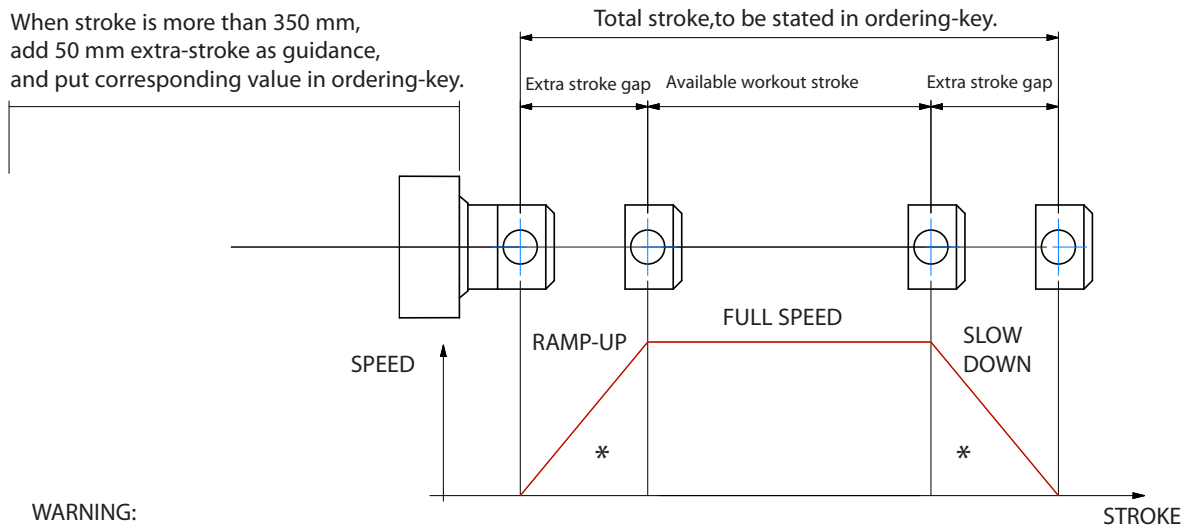

WARNING:

SPEED-TIMING ALONG STROKELENGTH:

ramps are extremely important when speed is > 40mm/s !!! Inverter or PWM drive recommended!

* The more speed raises the more extra stroke has to raise too.

BUCKLING: When stroke is longer than 500mm, BUCKLING can be a risk: please check mounting with our offices and/or see user-manuals.

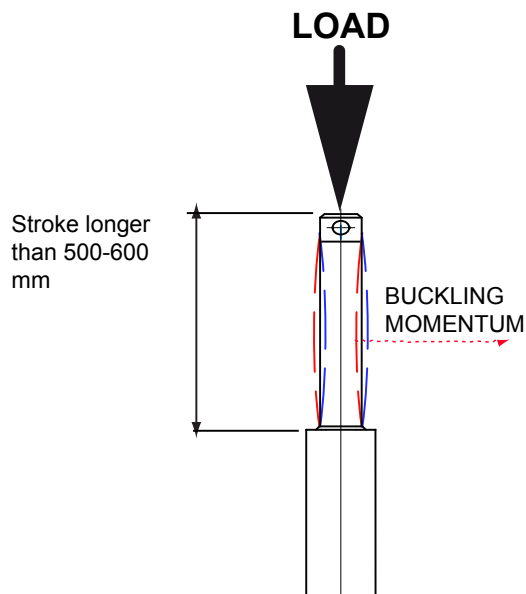

IMPORTANT:

Long strokes, even if load is low, can generate significant buckling momentums, as sketch slows.

This happens when actuator is in its all-opened position: that's the reason why we recommend 100 mm extra-stroke.

Pushtube will have this 100 mm-portion always inside the overtube, improving guidance against buckling.

For more information on this, contact our office.

ECV9092 / 0250 / M01 / CA-400/50-T-90-4-1,5 / 90B5+AB / 1 / M1 / E05 / 2FC2 / P0T01A / P1 / A1

MODEL: _____
ECV9092

STROKE: mm _____
es. 250 mm = 0250

VERSION: (pag. 53) _____
M01 / M02 / M03 / M04
M00 = Not standard speed
Flanged Version:
Advise reduction ratio and screw pitch

MOTOR: (pag. ACCESSORIES) _____
Advise only if with motor:
version, voltage, type, size, n°pole, power
With motorflange only put 0
With special motorflange put: PD

AC MOTOR OPTIONS: (pag. ACCESSORIES) _____
Motorflange: for motorflange version only advise size - i.e.for IEC80 B14 put 80B14
No motor: leave all following parameters blank
Protection Degree: IP65, for selfbrake motor IP54 standard
Brake type: for brakemotors only: ES. FECA
Options: Advise if needed (ES. AB 2'shaft)

E-BOX POSITION: _____
1 No motor: Leave blank

MOTOR POSITION: _____
M0 = standard M1 = SX

ENCODER: (pag. ACCESSORIES) _____
None: Leave blank

LIMIT SWITCHES: (pag. ACCESSORIES) _____
None: Leave blank

POTENTIOMETER: (pag. ACCESSORIES) _____
POT01A (1Kohm) POT10A (10Kohm) None: Leave blank

REAR END: _____
P1 = Eyelet (standard) P2 = Eyelet (90°)

FRONT END: _____
A1 = Eyelet (Std pag. 54) A3 = Yoke + Clip
A4 = Rod end A7 = M12 male

NOTE: COMPLETE THE ORDERING KEY ADDING THE OPTIONS YOU CAN FIND IN THE "ACCESSORIES AND OPTIONS" SECTION. _____

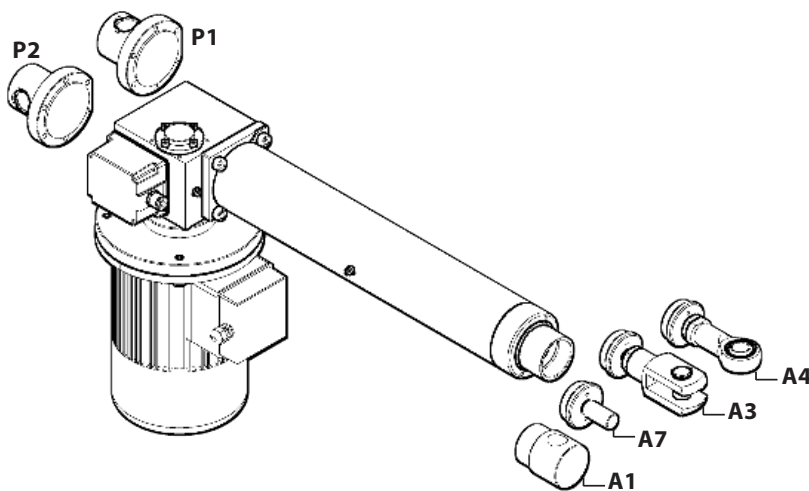

Note: "B" dimension changes according to model
ECV9092 = See pictures
Bellows = + 25 mm
with safety nut "G" = +50 mm

