

ALI5-P Cross gears CE ALI5-PB Belt drive

- Three phase or single phase motor CE
 - Cross gears (ALI5-P)
 - Belt drive (ALI5-PB)
 - Acme lead screw or ballscrew (VRS)
 - Chrome plated steel push road
 - Grease (standard) or oil (VRS continuous duty S1) lubricated only P version
 - IP65, tested according to rule CEI EN 60529
 - NB: Only for brake motors Standard IP54, IP65 on request
 - Working temperature range -10°C +60°C
 - Intermittent duty S3 30% (5min) a +30°C acme lead screw version (*)
 - Continuous duty S1 +30°C ballscrew version (**)
 - Limit switch, potentiometer, encoder on request
 - At-Ex II 3 D T4 version (A.C.motor) on request
- (*) For any special duty, please contact our technical department
(**) Performance are related to ball screw, lifetime of 2000 hours with steady load and without shocks or vibrations

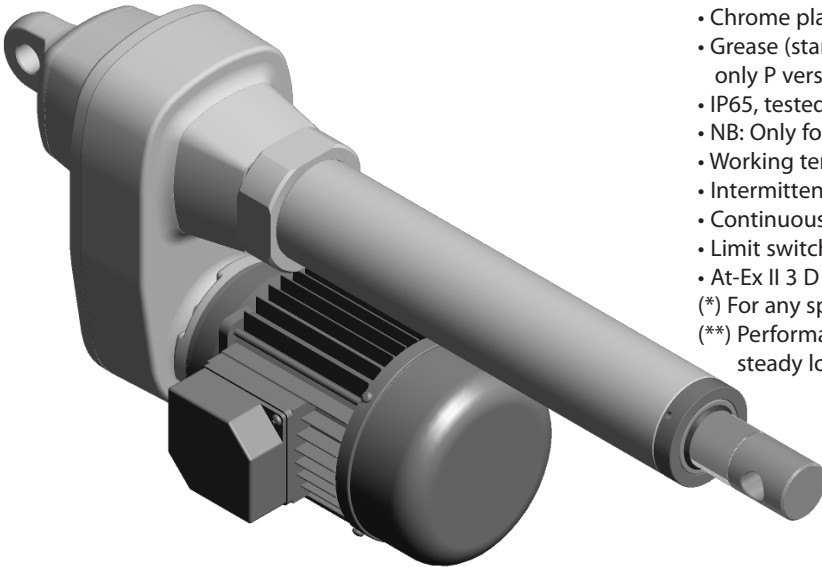

ALI5P - AC - ACME LEAD SCREW - S3 30% (5 min) 30°C					
Fmax (N)	Speed (mm/s)	Version	Motor size	Motor power (KW)	Motor speed (rpm)
* 2700	113	M11	IEC71	0.55	2800
* 4000	57	M12	IEC71	0.37	1400
6600	28	M13	IEC71	0.37	1400
15000	14	M14	IEC71	0.37	1400
15000	9	M15	IEC71	0.37	1400
15000	5	M16	IEC71	0.25	1400

ALI5P - AC - BALLSCREW - S1					
Fmax (N)	Speed (mm/s)	Version	Motor size	Motor power (KW)	Motor speed (rpm)
* 3900	113	M56	IEC71	0.55	2800
* 5500	57	M57	IEC71	0.37	1400
7000	28	M58	IEC71	0.37	1400
9000	14	M59	IEC71	0.25	1400
10000	9	M60	IEC71	0.25	1400

ALI5PB - AC - ACME LEAD SCREW - S3 30% (5 min) 30°C					
Fmax (N)	Speed (mm/s)	Version	Motor size	Motor power (KW)	Motor speed (rpm)
* 2800	233	M17	IEC80	1.10	2800
* 3300	194	M18	IEC80	1.10	2800
* 4600	117	M19	IEC80	1.10	2800
* 5500	97	M20	IEC80	1.10	2800
* 6900	58	M21	IEC80	0.75	1400
* 8300	49	M22	IEC80	0.75	1400

ALI5PB - AC - VRS - BALLSCREW - S1					
Fmax (N)	Speed (mm/s)	Version	Motor size	Motor power (KW)	Motor speed (rpm)
* 3600	223	M61	IEC80	1.10	2800
* 3800	194	M62	IEC80	1.10	2800
* 4300	117	M63	IEC80	0.75	1400
* 4500	97	M64	IEC80	0.55	1400
* 4500	49	M65	IEC71	0.25	1400

With single-phase motors type M (see motor choice guideline in paragraph ACCESSORIES) performances are 20% lower than the three-phase motor.

* When speed is more than 40 mm/s and/or strokes longer than 350mm, check STROKE SETUP section; BRAKEMOTOR IS RECOMMENDED

BEFORE OPERATING ACTUATOR MAKE SURE YOU READ AND UNDERSTOOD BASIC OPERATIONAL INSTRUCTIONS SHOWN ON USERMANUALS, AVAILABLE FROM WEBSITE.

THIS DOCUMENT DISPLAYS MOST TYPICAL STANDARD FEATURES AND SETUPS: CONTACT OUR OFFICES FOR MORE.

ACTUATOR SHALL NOT COME TO **MECHANICAL STROKE-END**, TO **AVOID FAILURES**.

CONSIDER MECVEL'S LIMITSWITCHES (MODEL ALI5-P-F or ALI5-PB-F) OR PUT THEM ON MACHINE/FRAME.



MecVel reserves the right to change products information and/or features without notice; all data contained in this catalogue are purely indicative and not binding for the company.

ALI5-P-PB Version without limitswitches

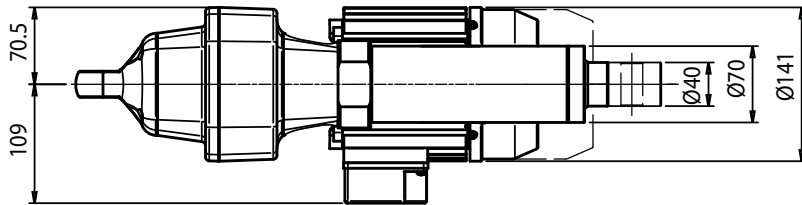
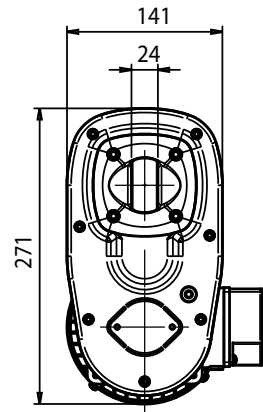
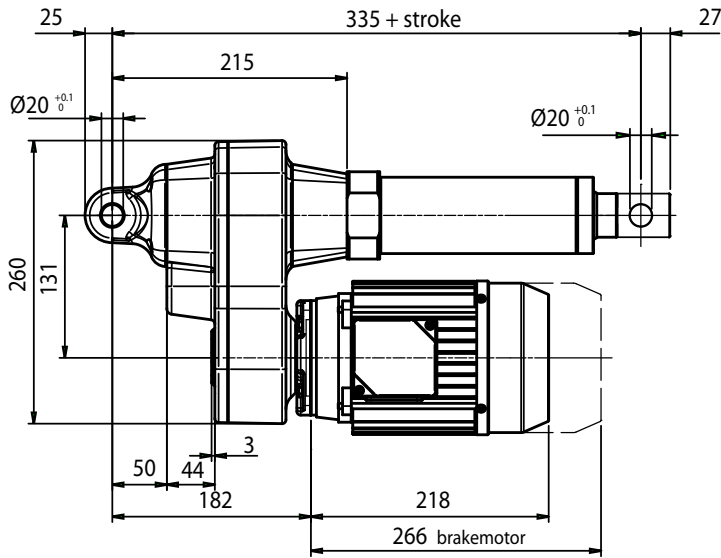

With safety nut "G" = + 50 mm
 Bellows + 25mm (for FCM limitswitches contact our Offices)

ALI5-P ALI5-PB

REAR ENDS

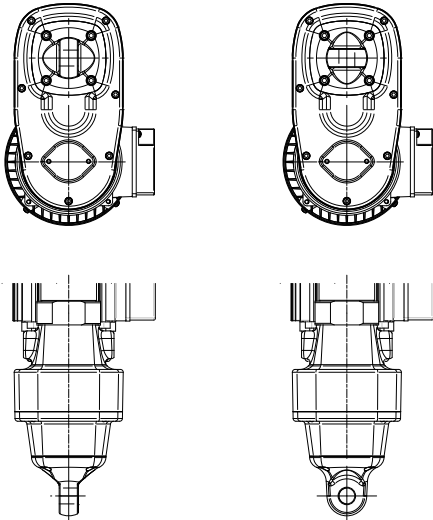

P1 Standard

P2 Ruotato 90°

E-BOX POSITION

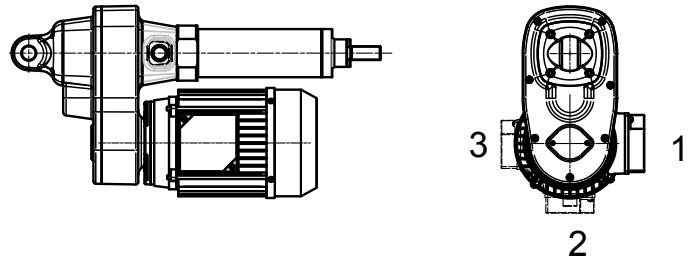

STROKE SETUP: Useful tips for handling stroke and avoid run-on-block collision.

When stroke is more than 350 mm, add 50 mm extra-stroke as guidance, and put corresponding value in ordering-key.

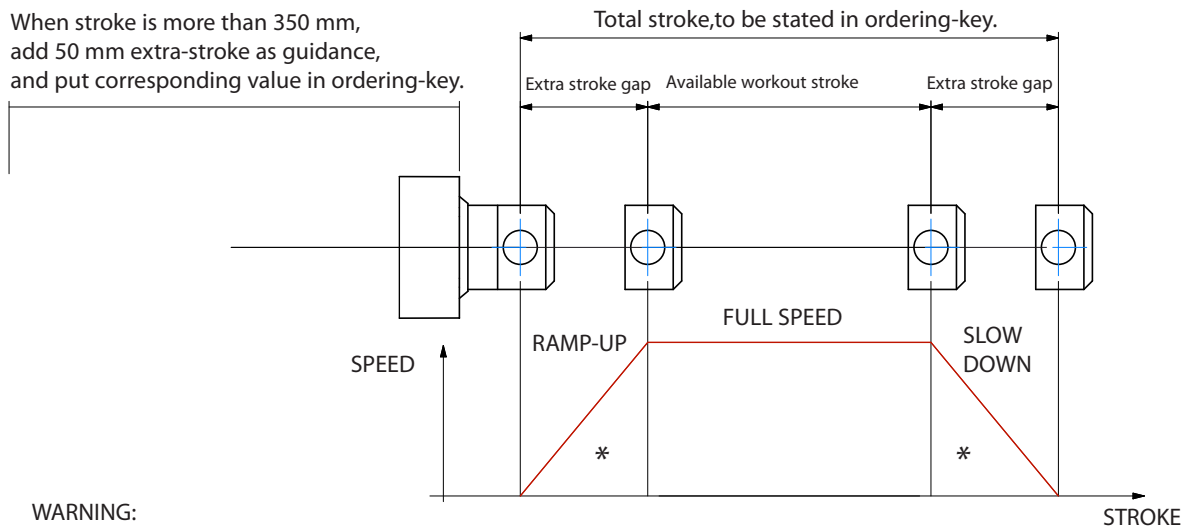

WARNING:

SPEED-TIMING ALONG STROKELENGTH:

ramps are extremely important when speed is > 40mm/s !!! Inverter or PWM drive recommended!

* The more speed raises the more extra stroke has to raise too.

BUCKLING: When stroke is longer than 500mm, BUCKLING can be a risk: please check mounting with our offices and/or see user-manuals.

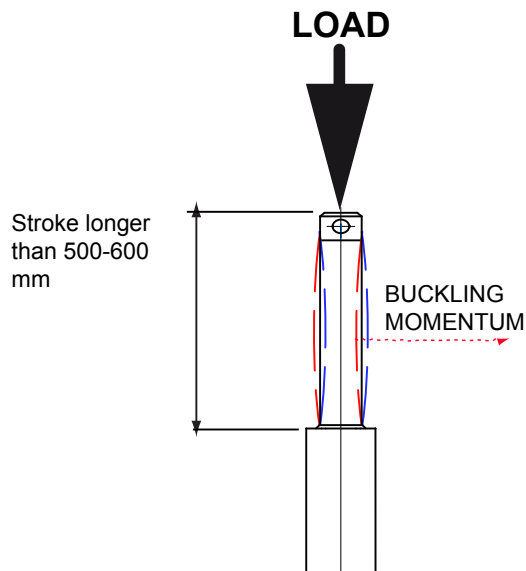

IMPORTANT:

Long strokes, even if load is low, can generate significant buckling momentums, as sketch slows.

This happens when actuator is in its all-opened position: that's the reason why we recommend 100 mm extra-stroke.

Pushtube will have this 100 mm-portion always inside the overtube, improving guidance against buckling.

For more information on this, contact our office.

ALI5-P / 0300 / M01 / CA-400-50-T-71-2-0,55 / B5 + AB / 1 / E05 / 2FCM0 / POT01A / P1 / A1

MODEL: _____
 ALI5-P / ALI5-PB / ALI5-P-FCM / ALI5-P-FCI
 ALI5-P-VRS / ALI5-P-VRS
 ALI5-P-VRS-FCM / ALI5-P-VRS-FCI

STROKE: _____
 es. 300 mm = 0300

VERSION: (pag.45) _____
 Advise: choose among
 Flanged Version = Rpm
 Advise reduction ratio and screw pitch (ALI5)

MOTOR: (pag. ACCESSORIES) _____
 Advise only if with motor:
 version, voltage, type, size, n°pole, power
 With motorflange only put 0
 With special motorflange put: PD

AC MOTOR OPTIONS: (pag. ACCESSORIES) _____
 Motorflange: for motorflange version only advise size - i.e.for IEC71 B14 put 71B14
 No motor: leave all following parameters blank
 Protection Degree: IP65, for selfbrake motor IP54 standard
 Brake type: for brakemotors only: ES. FECA
 Options: Advise if needed (ES. AB 2'shaft)

E-BOX POSITION: _____
 1 No Motor: Leave blank

ENCODER: (pag. ACCESSORIES) _____
 None: Leave blank

LIMIT SWITCHES: (psg. ACCESSORIES) _____
 None: Leave blank

POTENTIOMETER: (psg. ACCESSORIES) _____
POT01A (1Kohm) **POT10A** (10Kohm) None: / Leave blank

REAR END: _____
P1 = Eyelet **P2** = Eyelet (90°)

FRONT END: _____
A1 = Eyelet (Std pag. 46) **A3** = Yoke + Clip
A4 = Rod end **A7** = M20x1,5 male

NOTE: COMPLETE THE ORDERING KEY ADDING THE OPTIONS YOU CAN FIND IN THE "ACCESSORIES AND OPTIONS" SECTION

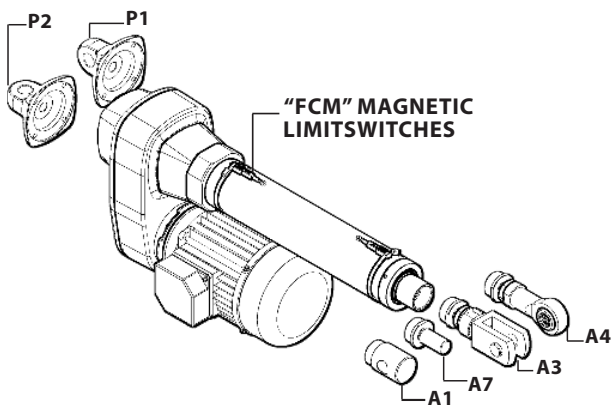

Note: "B" dimension variations depending on model

- | | |
|--|--|
| ALI5-P = See pictures | ALI5-P stroke > 500 = + 20 mm |
| ALI5-P-FCM stroke < 500 = + 40 mm | ALI5-P-FCM stroke > 500 = + 60 mm |
| ALI5-P-FCI stroke < 500 = + 30 mm | ALI5-P-FCI stroke > 500 = + 50 mm |
| ALI5-P-VRS stroke < 500 = + 88 mm | ALI5-P-VRS stroke > 500 = + 108 mm |
| ALI5-P-VRS-FCM stroke < 500 = + 128 mm | ALI5-P-VRS-FCM stroke > 500 = + 148 mm |
| ALI5-P-VRS-FCI stroke < 500 = + 118 mm | ALI5-P-VRS-FCI stroke > 500 = + 138 mm |

with safety nut "G" = + 50 mm (i.e. ALI5-P "G" option = +50)
 antirotation device "L" = + 15 mm
 Bellows = + 25 mm (excluding FCM and FCI. For version FCM and FCI contact MecVel)

