

- Permanent magnet DC motor 12-24 V
- Planetary gearbox
- Acme lead screw or ballscrew (VRS)
- Chrome plated steel push rod
- Permanent grease lubrication
- IP 65, tested according to rule CEI EN 60529
- Working temperature range -10°C +60°C
- Intermittent duty (see performance charts) a 30°C, for other solutions contact the MecVel Technical dept.
- Limit switches on request
- Encoder on request

L02 (Vdc)					
Fmax (N)	Speed (mm/s)	Version	Motor size	Gearmotor speed (rpm)	Max Current for Fmax (A) 24Vdc**
750	30	M04	36	500	4
840	20	M05	36	150	2
1600	10	M06	36	150	2,5
2000	5	M07	36	80	2

When speed is more than 40 mm/s and/or strokes longer than 350mm, check STROKE SETUP section.

** For 12 Vdc power supply currents are doubled and loads are 20% lower.

ACTUATOR SHALL NOT COME TO MECHANICAL STROKE-END, TO AVOID FAILURES.

BEFORE OPERATING ACTUATOR MAKE SURE YOU READ AND UNDERSTOOD BASIC OPERATIONAL INSTRUCTIONS SHOWN ON USERMANUALS, AVAILABLE FROM WEBSITE.

THIS DOCUMENT DISPLAYS MOST TYPICAL STANDARD FEATURES AND SETUPS: CONTACT OUR OFFICES FOR MORE.

CONSIDER MECVEL's LIMITSWITCHES (MODEL L02-F or L02-FCM) OR PUT THEM ON MACHINE/FRAME.



MecVel reserves the right to change products information and/or features without notice; all data contained in this catalogue are purely indicative and not binding for the company.

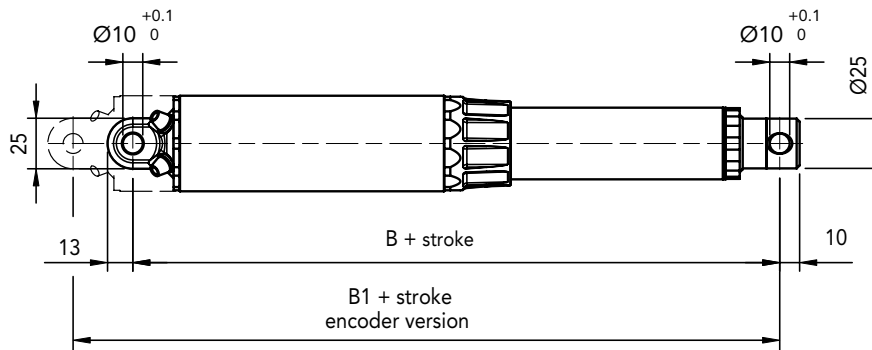
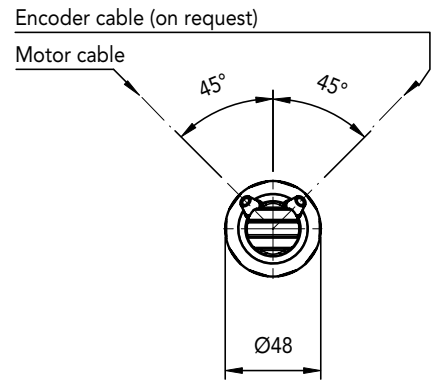
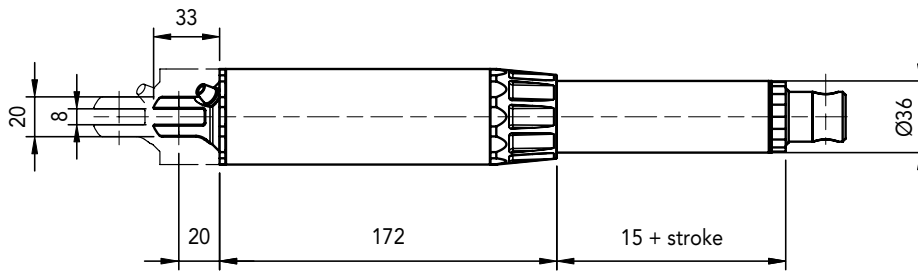

DIMENSION	stroke < 320 mm	stroke > 320 mm
B	228 + stroke	239 + stroke
B1	257 + stroke	268 + stroke

STROKE SETUP

Useful tips for handling stroke and avoid run-on-block collision.

- When stroke is more than 350 mm, add 50 mm extra-stroke as guidance, and put corresponding value in ordering-key.
- **WARNING SPEED-TIMING ALONG STROKELENGTH:** ramps are extremely important when speed is >30 mm/s!!! Inverter or PWM drive recommended!
- The more speed raises the more extra stroke has to raise too.

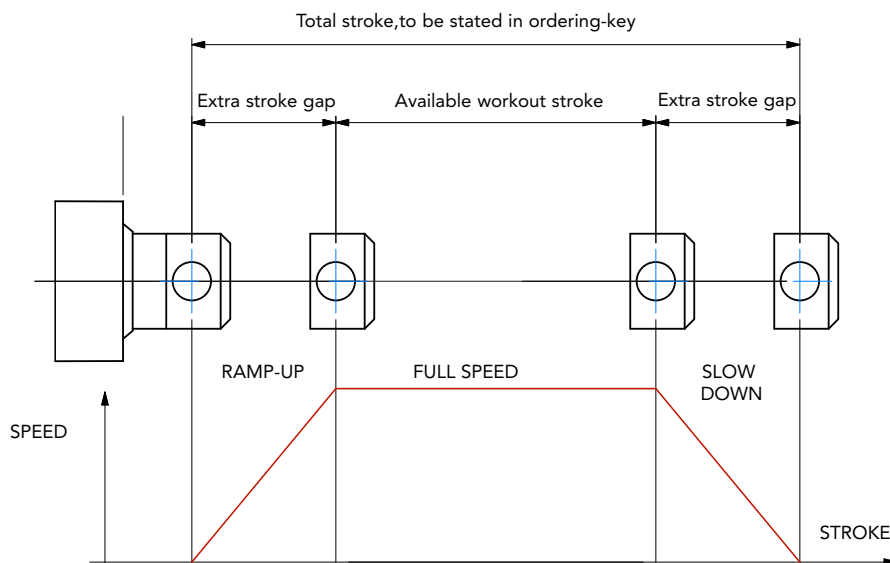

BUCKLING

When stroke is longer than 500mm, BUCKLING can be a risk: please check mounting with our offices and/or see usermanuals.

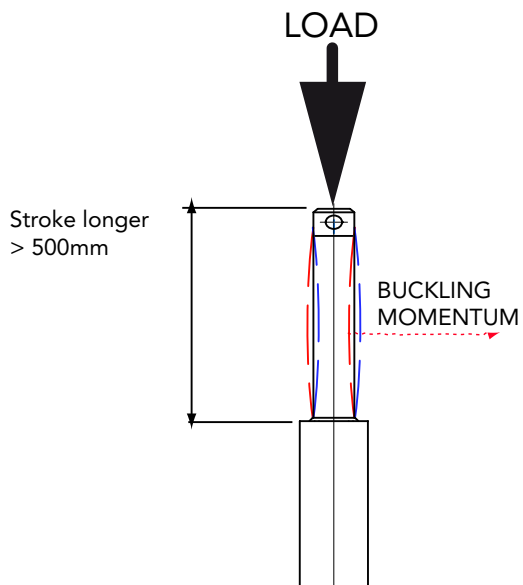

IMPORTANT:

Long strokes, even if load is low, can generate significant buckling momentums, as sketch slows. This happens when actuator is in its all-opened position: that's the reason why we recommend 100 mm extra-stroke. Pushtube will have this 100 mm-portion always inside the overtube, improving guidance against buckling.

For more information on this, contact our office.

L02/0250/M07/24/E10/2FCM0/P1/A1/

MODEL _____
 L02 _____ L02-FCM _____

STROKE _____
 es. 250 mm = 0250 _____

VERSION _____
 M04 / M05 / M06 / M07 _____
 M00 = Not standard speed _____

MOTOR _____
 12 = 12 Vdc _____ 24 = 24 Vdc _____

LIMIT SWITCHES _____
 None: Leave blank _____

ENCODER _____
 options pg.76 _____ none: leave blank _____

REAR END _____
 P1 = Yoke (standard) _____ P2 = Special (provide drawing) _____

FRONT END _____
 A1 = Eyelet (standard) _____ A3 = Yoke + Clip _____ A4 = Rod end _____ A7 = M10 male _____

NOTE: COMPLETE THE ORDERING KEY ADDING THE OPTIONS YOU CAN FIND IN THE "ACCESSORIES AND OPTIONS" SECTION

P1 / P2

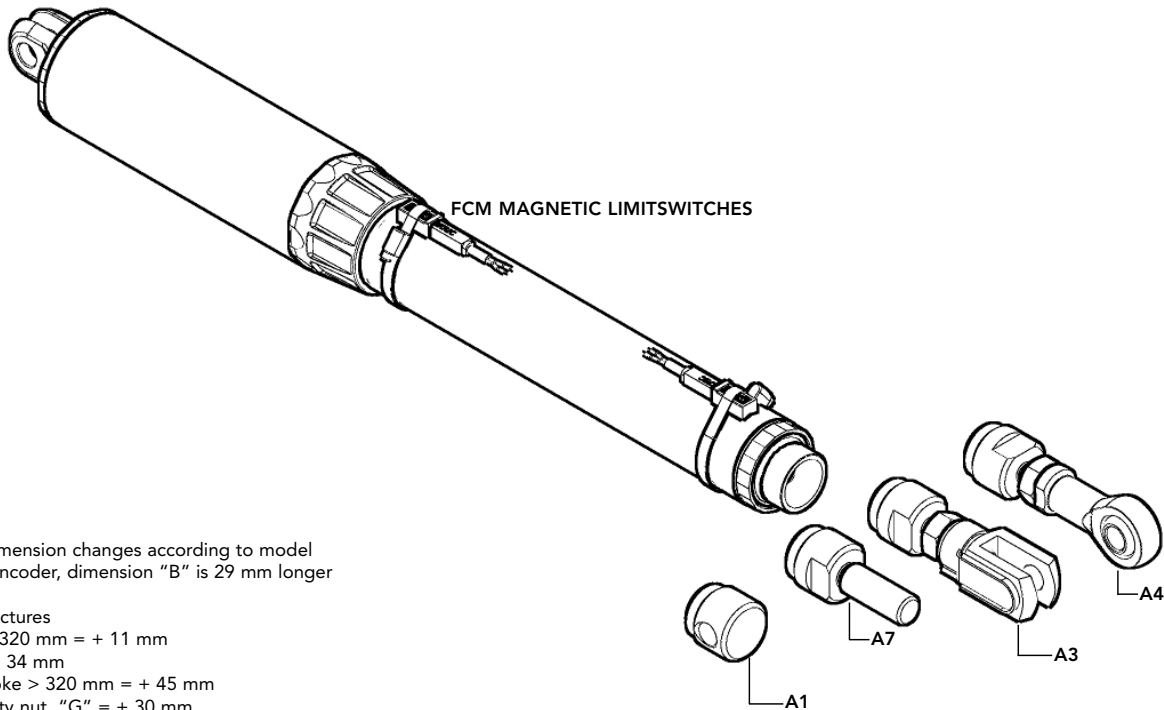

Note: "B" dimension changes according to model
Note: With encoder, dimension "B" is 29 mm longer

- L02 = See pictures
- L02 stroke > 320 mm = + 11 mm
- L02-FCM = + 34 mm
- L02-FCM stroke > 320 mm = + 45 mm
- L02 with safety nut "G" = + 30 mm
- L02-VRS = + 40 mm
- L02 with Bellows + 20mm (no for versions FCM)

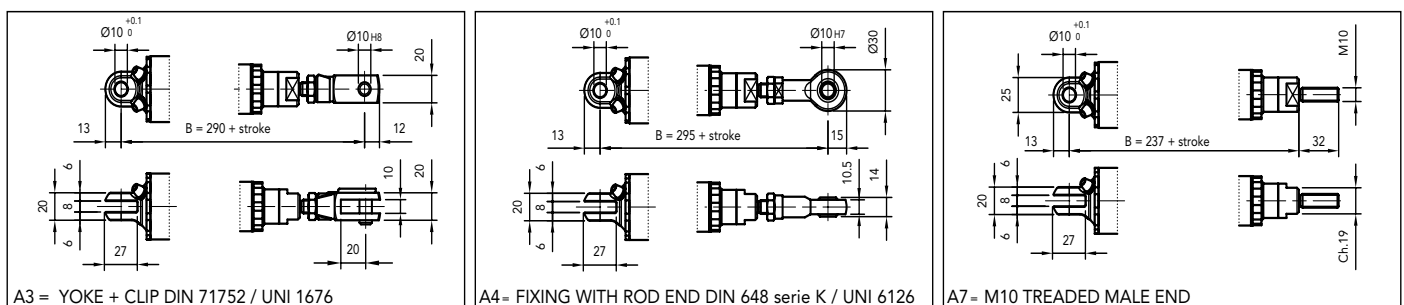

- Permanent magnet DC motor
- Planetary gearbox
- Acme lead screw or ballscrew (VRS)
- Chrome plated steel push rod
- Permanent grease lubrication
- IP65, tested according to rule CEI EN 60529
- Working temperature range -10°C +60°C
- Limit switches on request
- Encoder on request

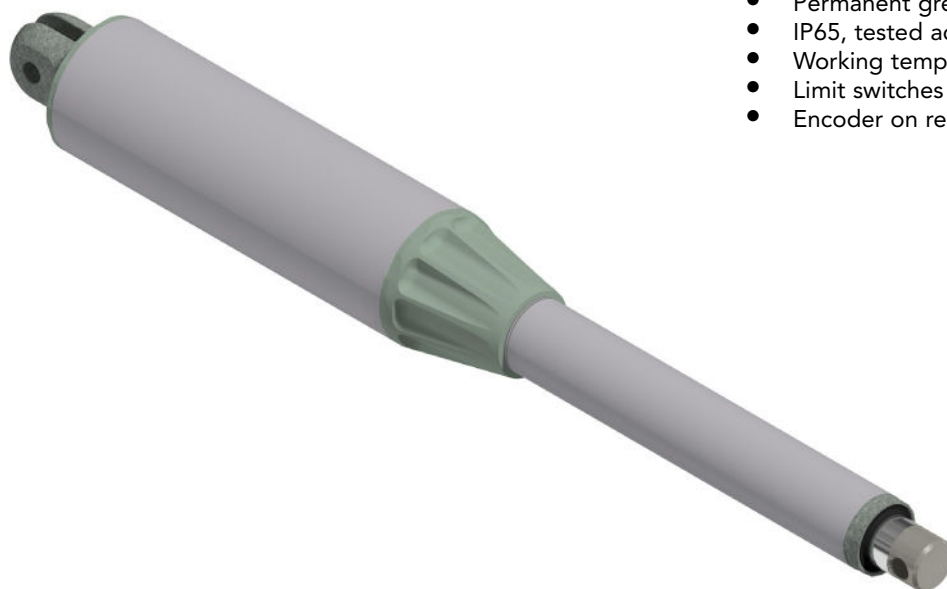

L03 (Vdc)						
Fmax (N)	Speed (mm/s)	Version	Motor size	Gearmotor speed (rpm)	Max Current for F max (A) 24Vdc**	Fs % base 5 min.
3000	20	M01	51	155	9	10
5000	10	M02	51	155	10,5	10
2000	30	M03	51	155	7,5	20

L03 VRS (ballscrew) (Vdc)						
Fmax (N)	Speed (mm/s)	Version	Motor size	Gearmotor speed (rpm)	Max Current for F max (A) 24Vdc	Fs % base 5 min.
5000	13	M01	51	155	5,5	30

When speed is more than 40 mm/s and/or strokes longer than 350mm, check STROKE SETUP section.

** For 12 Vdc power supply currents are doubled and loads are 20% lower.

BEFORE OPERATING ACTUATOR MAKE SURE YOU READ AND UNDERSTOOD BASIC OPERATIONAL INSTRUCTIONS SHOWN ON USERMANUALS, AVAILABLE FROM WEBSITE.

THIS DOCUMENT DISPLAYS MOST TYPICAL STANDARD FEATURES AND SETUPS: CONTACT OUR OFFICES FOR MORE.

ACTUATOR SHALL NOT COME TO MECHANICAL STROKE-END, TO AVOID FAILURES, CONSIDER MECVEL'S LIMITSWITCHES (MODEL L03-F or L03-FCM) OR PUT THEM ON MACHINE/FRAME.

 MecVel reserves the right to change products information and/or features without notice; all data contained in this catalogue are purely indicative and not binding for the company.

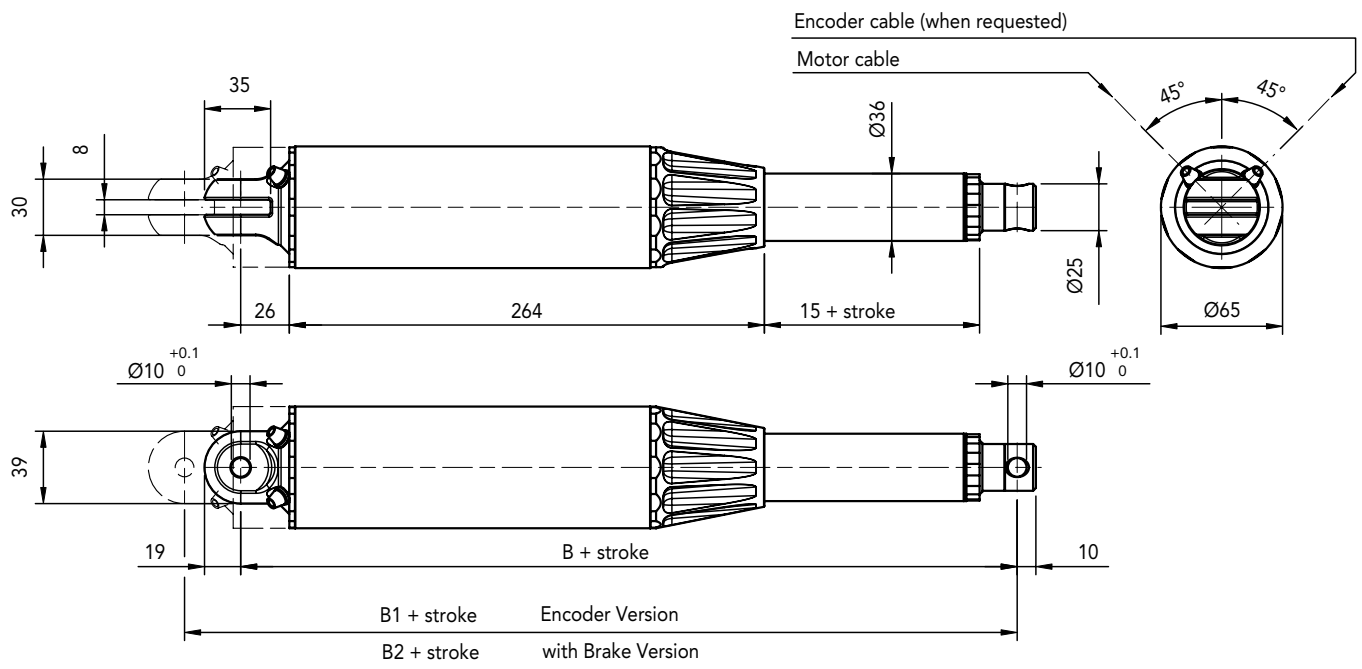

	DIMENSION	Stroke < to 320 mm.	Stroke > to 320 mm.
Version without Encoder and Brake	B	325 + stroke	336 + stroke
Version without Encoder (not compatible with brake version)	B1	355 + stroke	366 + stroke
Version without Brake (not compatible with encoder version)	B2	355 + stroke	366 + stroke

STROKE SETUP

Useful tips for handling stroke and avoid run-on-block collision.

- When stroke is more than 350 mm, add 50 mm extra-stroke as guidance, and put corresponding value in ordering-key.
- **WARNING SPEED-TIMING ALONG STROKELENGTH:** ramps are extremely important when speed is >30 mm/s!!! Inverter or PWM drive recommended!
- The more speed raises the more extra stroke has to raise too.

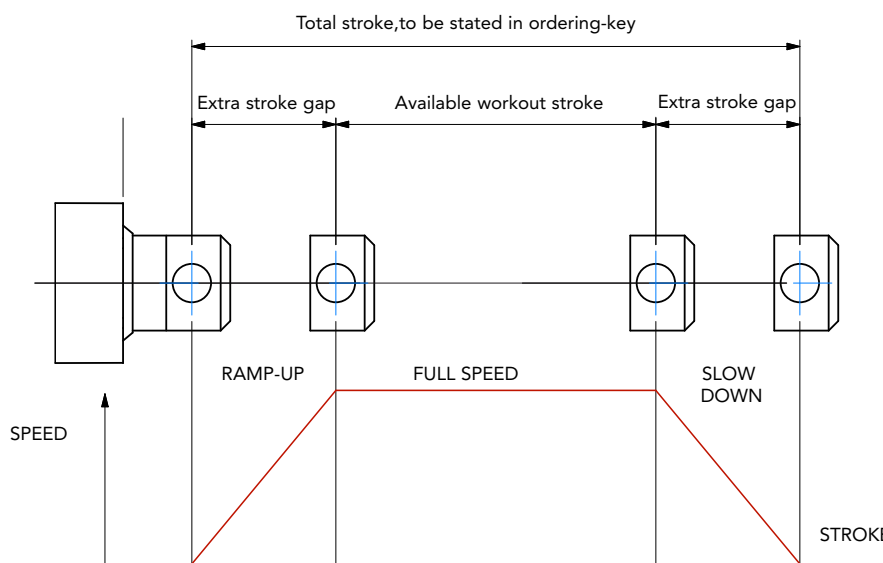

BUCKLING

When stroke is longer than 500mm, BUCKLING can be a risk: please check mounting with our offices and/or see usermanuals.

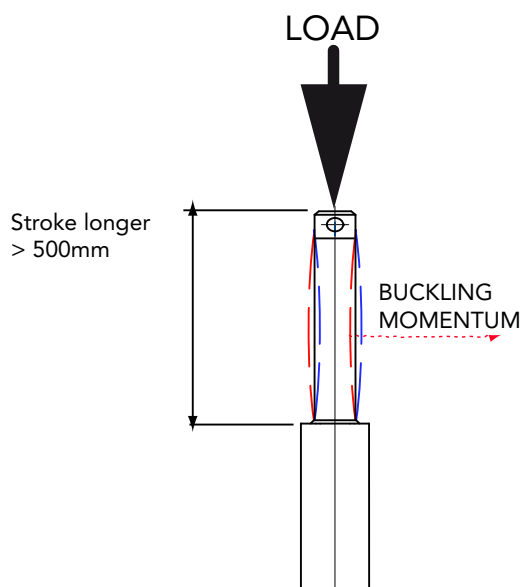

IMPORTANT:

Long strokes, even if load is low, can generate significant buckling momentums, as sketch shows. This happens when actuator is in its all-opened position: that's the reason why we recommend 100 mm extra-stroke. Pushtube will have this 100 mm-portion always inside the overtube, improving guidance against buckling.

For more information on this, contact our office.

L03/0250/M02/24/E50/2FCM0/P1/A1/

MODEL _____
 L03 L03 VRS L03-FCM

STROKE _____
 es. 250 mm = 0250

VERSION _____
 M01 / M02 / M03
 M00 = Not standard speed

MOTOR _____
 12 = 12 Vdc 24 = 24 Vdc

ENCODER _____
 Options pg.76 None: leave blank

LIMIT SWITCH _____
 None: leave blank

REAR END _____
 P1 = Yoke (standard) P2 = Special (provide technical drawing)

FRONT END _____
 A1 = Eyelet (standard) A3 = Yoke + Clip A4 = Rod end A7 = M10 male

NOTE: COMPLETE THE ORDERING KEY ADDING THE OPTIONS YOU CAN FIND IN THE "ACCESSORIES AND OPTIONS" SECTION

P1 / P2

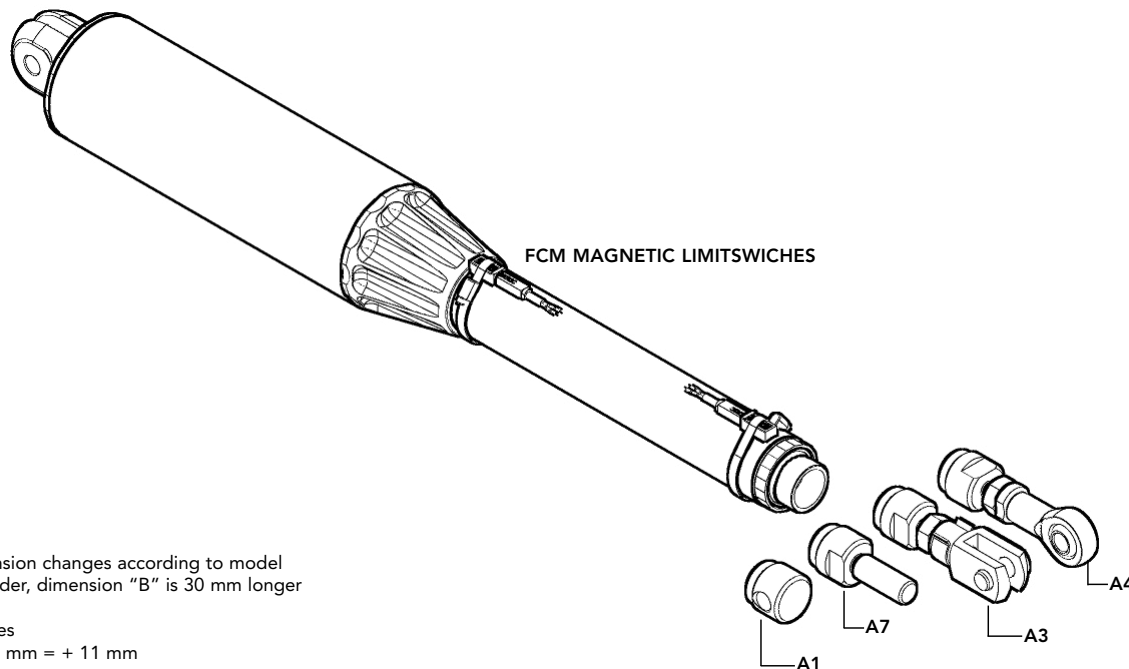

Note: "B" dimension changes according to model
Note: With encoder, dimension "B" is 30 mm longer

- L03 = See pictures
- L03 stroke > 320 mm = + 11 mm
- L03-FCM = + 34 mm
- L03-FCM stroke > 320 mm = + 44 mm
- L03-VRS = + 40 mm
- L03 with safety nut "G" = + 30 mm
- L03 with bellows = + 20 mm (not compatible with FCM)

