

- Permanent magnet CC motor
- Three phase or single phase AC motor
- Worm gearbox
- Acme lead screw or ballscrew (VRS)
- Chrome plated steel push rod
- Life long grease lubricated
- IP55 AC
- IP65 DC, tested according to rule CEI EN 60529
NB: Only for brake motors Standard IP54, IP65 on request
- Working temperature range -10°C +60°C
- Intermittent duty S3 30% (5 min) a +30°C for AC motors
- Limit switches, potentiometer and encoder on request

ALI2 (Vac tri-phase)				
Fmax (N)	Speed (mm/s)	Version	Motor size	Motor power (KW)
450 *	110	M01	IEC56	0.09 2 poles
500 *	70	M02	IEC56	0.09 2 poles
650 *	50	M03	IEC56	0.09 2 poles
850 *	40	M04	IEC56	0.09 2 poles
1000	30	M05	IEC56	0.06 4 poles
1400	20	M06	IEC56	0.06 4 poles
2200	10	M07	IEC56	0.06 4 poles
2500	5	M08	IEC56	0.06 4 poles

ALI2 VRS (Vac tri-phase)				
Fmax (N)	Speed (mm/s)	Version	Motor size	Motor power (KW)
1500 *	45	M01	IEC56	0.09 2 poles
1800	30	M02	IEC56	0.09 2 poles
2000	20	M03	IEC56	0.06 4 poles
2500	10	M04	IEC56	0.06 4 poles
2500	5	M05	IEC56	0.06 4 poles

ALI2 (Vdc)						
Fmax (N)	Speed (mm/s)	Version	Motor size	Motor speed (rpm)	Max Current for F max (A) 24Vdc**	Fs % base 5 min.
800 *	110	M08	59	3000	9	10
1100 *	55	M10	59	3000	7	30
1500 *	40	M11	59	3000	8,5	20
2000	30	M12	59	3000	8,5	20
2500	20	M13	59	3000	8	20
2500	10	M14	59	3000	5	30

With single-phase motors type M (see motor choice guideline in paragraph ACCESSORIES) performances are 20% lower than the three-phase motor.

For the DC models its is possible to add an IP20 break.

* When speed is more than 40 mm/s and/or strokes longer than 350mm, check STROKE SETUP section.

** For 12 Vdc power supply currents are doubled and loads are 20% lower.

 → The brakemotor is strongly recommended

BEFORE OPERATING ACTUATOR MAKE SURE YOU READ AND UNDERSTOOD BASIC OPERATIONAL INSTRUCTIONS SHOWN ON USERMANUALS, AVAILABLE FROM WEBSITE.

THIS DOCUMENT DISPLAYS MOST TYPICAL STANDARD FEATURES AND SETUPS: CONTACT OUR OFFICES FOR MORE. ACTUATOR SHALL NOT COME TO MECHANICAL STROKE-END, TO AVOID FAILURES. CONSIDER MECVEL's LIMITSWITCHES (MODEL ALI2-F or ALI2-FCM) OR PUT THEM ON MACHINE/FAME.

 MecVel reserves the right to change products information and/or features without notice; all data contained in this catalogue are purely indicative and not binding for the company.

VERSION WITHOUT LIMITSWITCHES

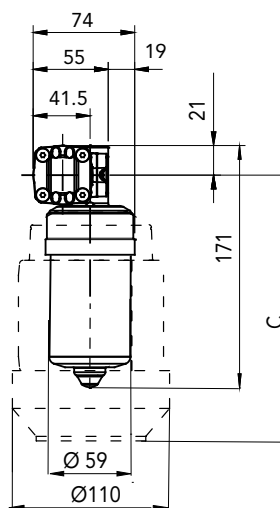
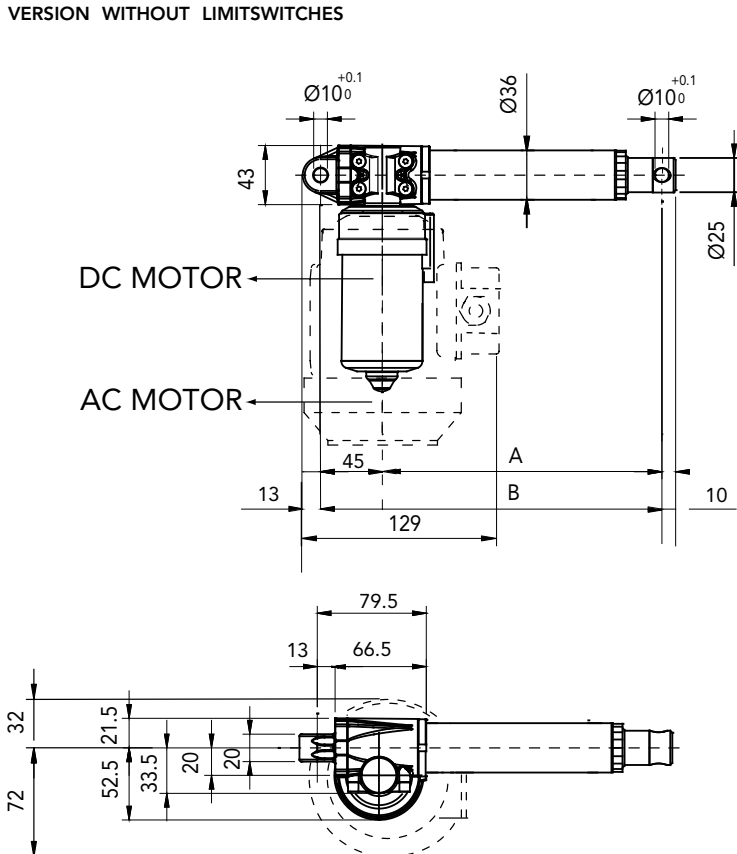

DIMENSION	Stroke < to 320 mm	Stroke > to 320 mm
A	70 + stroke	80 + stroke
B	115 + stroke	125 + stroke
C with brake	254.5	
C without brake	209.5	

VERSION WITH LIMITSWITCHES

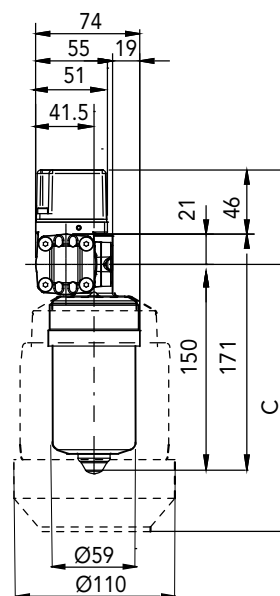
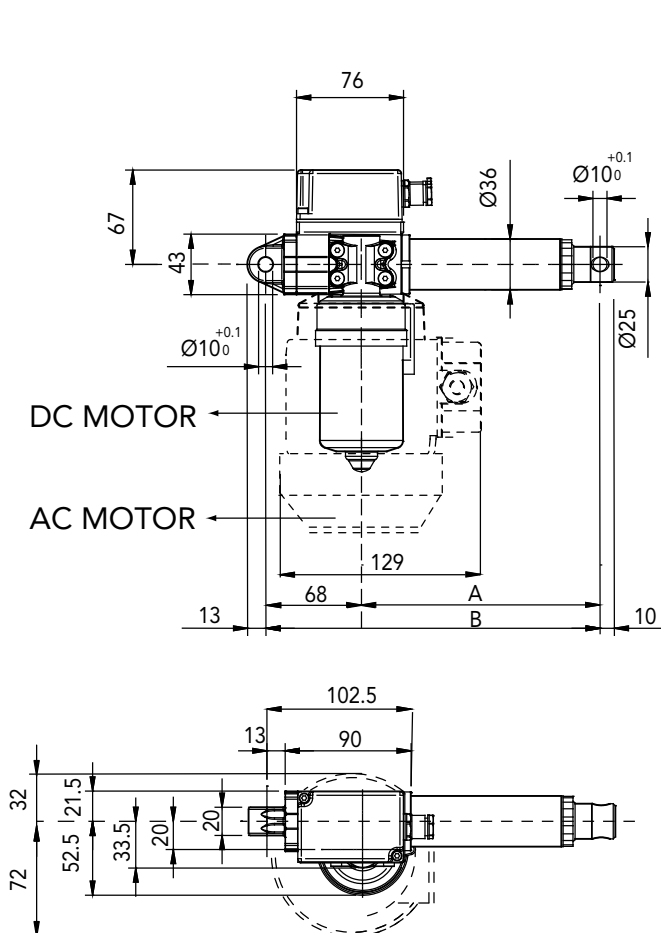

DIMENSION	Stroke < to 320 mm	Stroke > to 320 mm
A	70 + stroke	80 + stroke
B	138 + stroke	148 + stroke
C with brake	254.5	
C without brake	209.5	

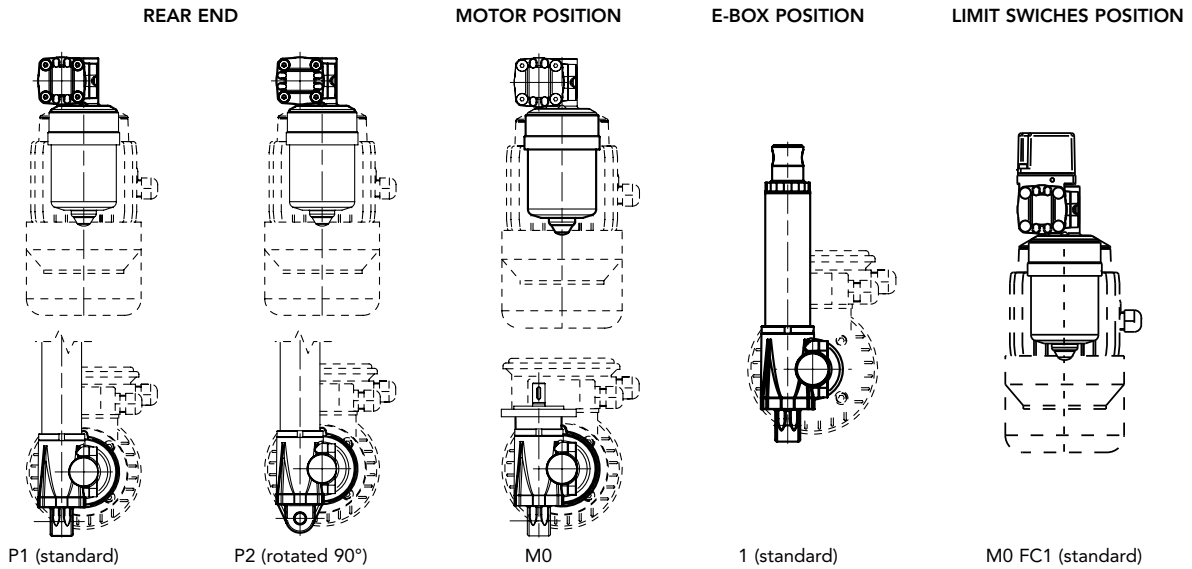

STROKE SETUP

Useful tips for handling stroke and avoid run-on-block collision.

- When stroke is more than 350 mm, add 50 mm extra-stroke as guidance, and put corresponding value in ordering-key.
- **WARNING SPEED-TIMING ALONG STROKELENGTH:** ramps are extremely important when speed is >30 mm/s!!! Inverter or PWM drive recommended!
- The more speed raises the more extra stroke has to raise too.

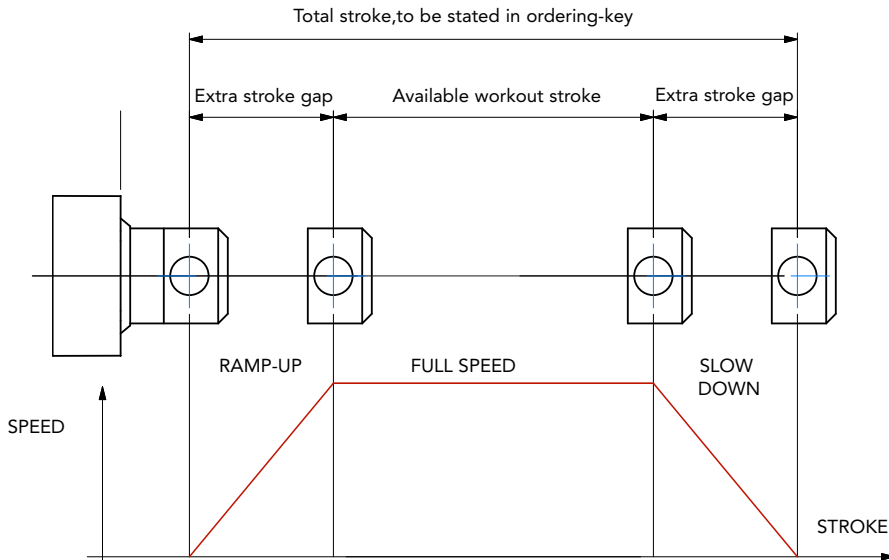

BUCKLING

When stroke is longer than 500mm, BUCKLING can be a risk: please check mounting with our offices and/or see usermanuals.

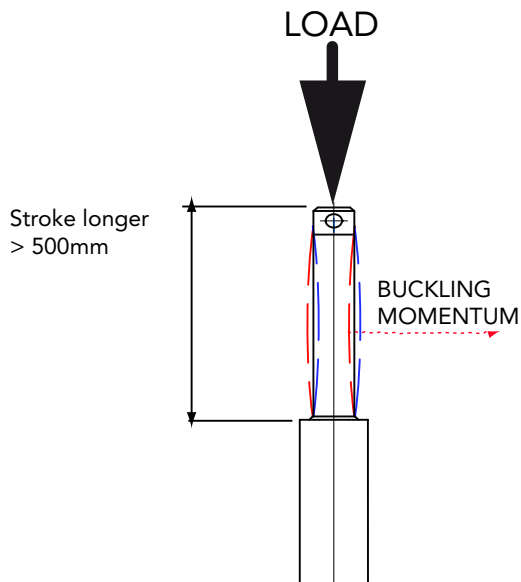

IMPORTANT:

Long strokes, even if load is low, can generate significant buckling momentums, as sketch slows. This happens when actuator is in its all-opened position: that's the reason why we recommend 100 mm extra-stroke. Pushtube will have this 100 mm-portion always inside the overtube, improving guidance against buckling.

For more information on this, contact our office.

ALI2/0250/M04/CA-400/50-T-56-2-0,09/AB/M0/1/E06/2FC1/POT01A/FC1/P1/A1/

MODEL _____
 ALI2 / ALI2-F / ALI2-VRS / ALI2-F-VRS / ALI2-FCM / ALI2-FCM-VRS

STROKE (mm) _____
 es. 250 mm = 0250

VERSION _____
 M08 / M10 / M11 / M12 / M13 / M14 (DC)
 M01 / M02 / M03 / M04 / M05 / M06 / M07 / M08 (AC)
 M00 = Not standard speed

MOTOR _____
 A.C. version, voltage, type, size, n°pole, power
 D.C. version, voltage, size, Rpm

AC MOTOR OPTION _____
 No motor or DC motor: leave all following parameters blank
 Protection Degree: IP65, for selfbrake motor IP54 standard
 Brake type: for brakemotors only: ES. FECA
 Options: Advise if needed (ES. AB 2'shaft)

MOTOR POSITION _____
 M0 None: Leave blank

E-BOX POSITION _____
 1

ENCODER (Pag. ACCESSORIES) _____
 Options pg.76 None: Leave blank

LIMIT SWITCHES (Pag. ACCESSORIES) _____
 2FC1 None: Leave blank

POTENTIOMETER (Pag. ACCESSORIES) _____
 POT01A (1Kohm) POT10A (10Kohm) None: / Leave blank

LIMIT SWITCHES POSITION _____
 FC1 None: Leave blank

REAR END _____
 P1 = Eyelet (standard) P2 = Eyelet (90°)

FRONT END _____
 A1 = Eyelet A3 = Yoke + Clip A4 = Rod end A7 = M10 male

NOTE: COMPLETE THE ORDERING KEY ADDING THE OPTIONS YOU CAN FIND IN THE "ACCESSORIES AND OPTIONS" SECTION

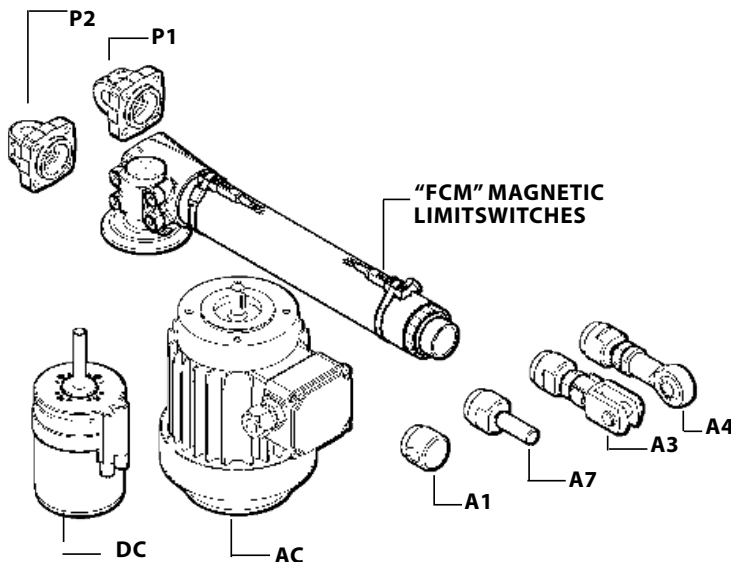

Note: "B" dimension changes according to model

- ALI2 = See pictures
- ALI2 stroke > 320 mm = + 10 mm
- ALI2-FCM = + 34 mm
- ALI2-FCM stroke > 320 mm = +44
- ALI2-F = + 23 mm
- ALI2-F stroke > 320 mm = + 33 mm
- With safety nut "G" = + 30 mm
- ALI2-VRS = + 40 mm
- ALI2-F-VRS = + 63 mm
- Bellows + 20mm

