

- Permanent magnet motor 12 - 24 Vdc
- Double worm gearbox
- ACME lead screw
- Aluminum push rod (Stainless steel on request)
- Permanent grease lubrication
- IP 65, tested according to rule CEI EN 60529
- Working temperature range -10°C +60°C
- Intermittent duty S3 30% (5 min) a 30°C
- Encoder on request
- Limit switches on request (ALI1-PF)

ALI1-P (Vdc)					
Fmax (N)	Speed (mm/s)	Version	Motor size	Motor speed (rpm)	Max Current for F max(A) 24Vdc**
1200	16,5	M01	40	6000	2,5
1550	11	M02	40	6000	2
2000	8,3	M03	40	6000	2,5
2500	5,6	M04	40	6000	2,5
2500	2,8	M05	40	6000	1,5
2500	0,9	M06	40	6000	1

When stroke is longer than 200 mm, check STROKE SETUP section.

** For 12 Vdc power supply currents are doubled and loads are 20% lower.

BEFORE OPERATING ACTUATOR MAKE SURE YOU READ AND UNDERSTOOD BASIC OPERATIONAL INSTRUCTIONS SHOWN ON USERMANUALS, AVAILABLE FROM WEBSITE.

THIS DOCUMENT DISPLAYS MOST TYPICAL STANDARD FEATURES AND SETUPS: CONTACT OUR OFFICES FOR MORE.

ACTUATOR SHALL NOT COME TO MECHANICAL STROKE-END, TO AVOID FAILURES.
CONSIDER MECVEL's LIMITSWITCHES (MODEL ALI1-PF) OR PUT THEM ON MACHINE/FRAME.



MecVel reserves the right to change products information and/or features without notice; all data contained in this catalogue are purely indicative and not binding for the company.

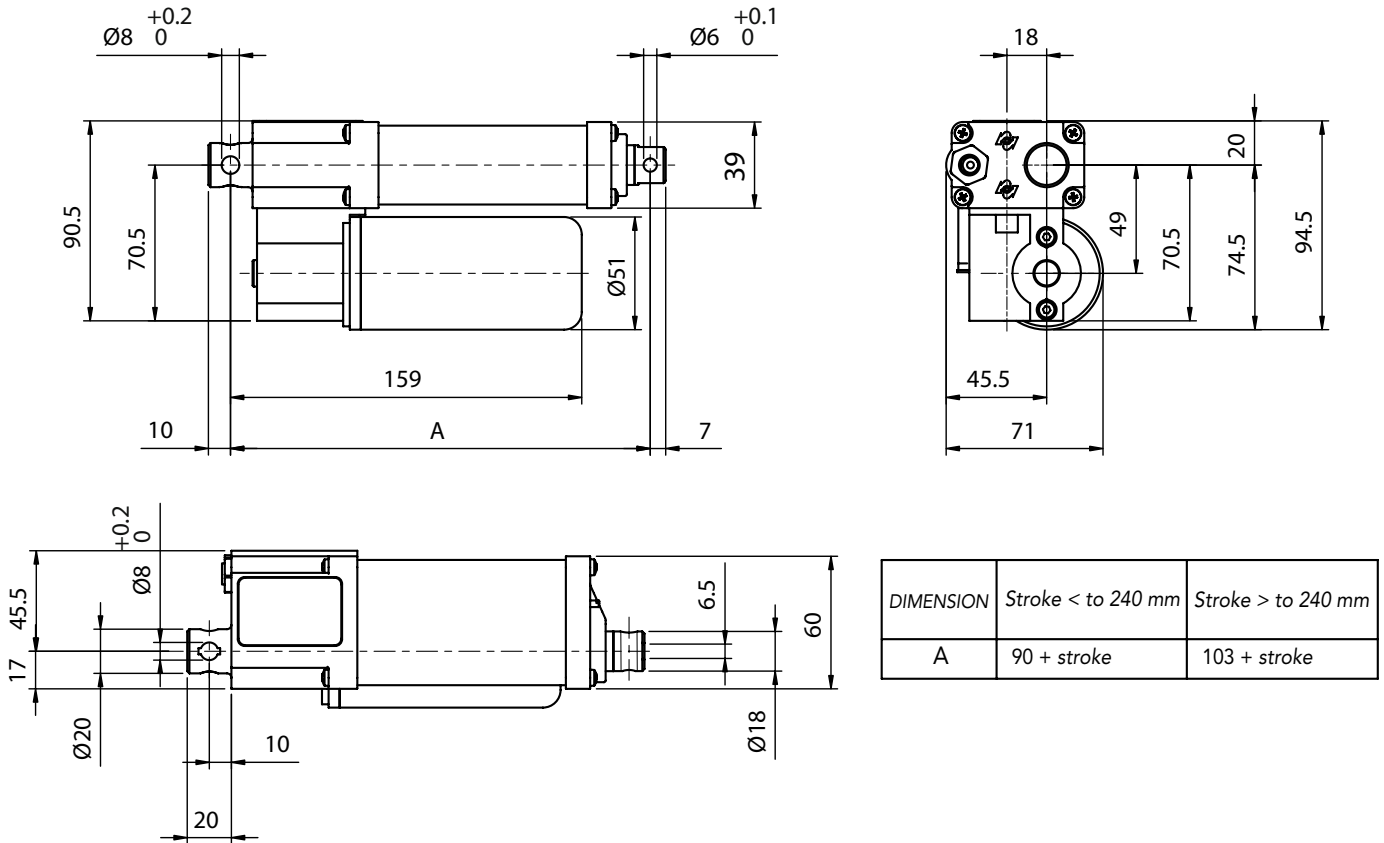

ELECTRICAL WIRINGS

Options available:

- C01/C08 motor
- C02/C09 N° 2 microswitches, diode-wired
- C03/C10 motor + N° 2 micro
- C04/C11 motor + N° 3 micro
- C05/C12 motor + encoder
- C06/C13 N° 2 micro diode wired + encoder
- C07/C14 motor + N° 2 micro + encoder
- C00 special wiring (Presence of not standard options)

WARNING

Micros are actuated by a cam lying on push-rod itself. Micro signal, for high speeds needs to be handled in its very impulse (I.E. when actuated) and not in its state. Alternatively, MecVel can add a bush to keep the microswitch lever pressed for a longer time avoiding switch signal mistakes, but cause loss of 10 mm of stroke. Connections C02 and C06 make a circuit which stops motor supply, so that the push rod won't overstep the area of the two micros. This system can work only if inertia generated by the actuator and load connected to it does not allow to over-step the micro when stroke is over. So, this works just with low speeds (M01 - M03), with a load opposing the ongoing direction of the push rod. If not, relay or PLC solutions, using C03 and C07 connections, are needed. Wiring diagrams of connections above are following:

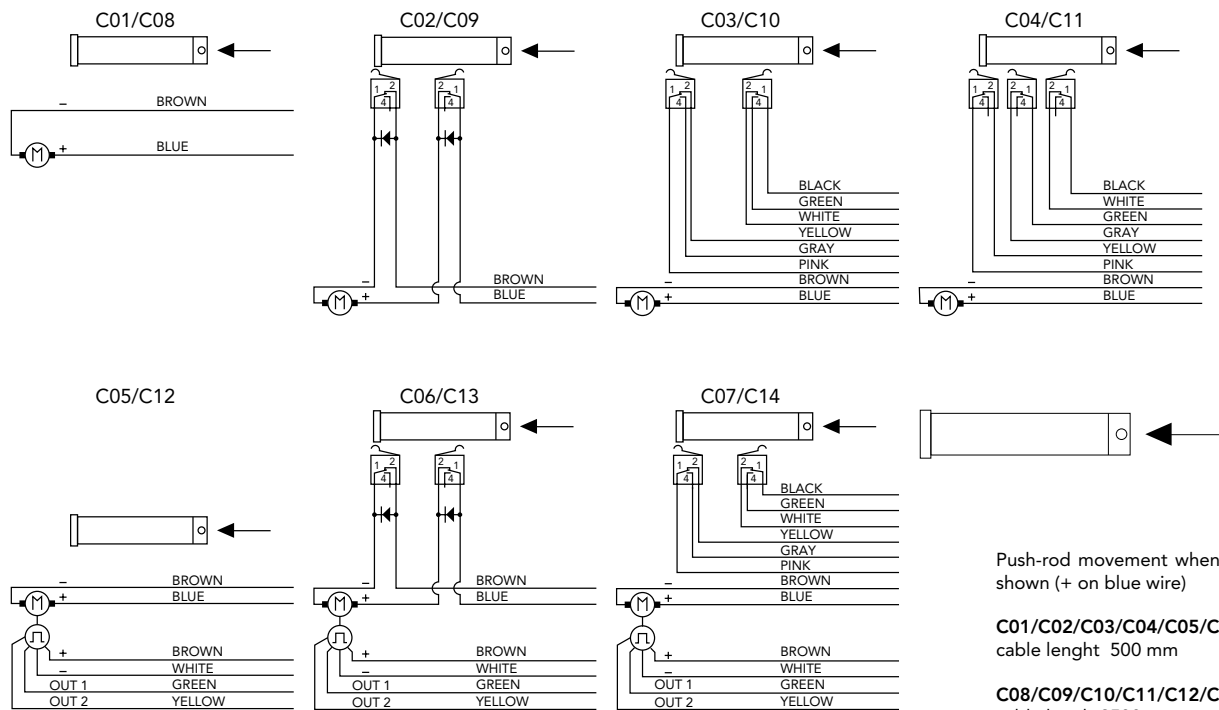

Push-rod movement when power supply is as shown (+ on blue wire)

C01/C02/C03/C04/C05/C06/C07: cable length 500 mm

C08/C09/C10/C11/C12/C13/C14: cable length 2500 mm

ANTIROTATION DEVICE

Model ALI1-PF can host an antirotation device, allowing push rod not to spin when travelling. Front ends A1 and A2 allow for two antirotation settings, AR0 and AR1. When using A3, A4, A5 and A7 front ends antirotation facility must always be mounted.

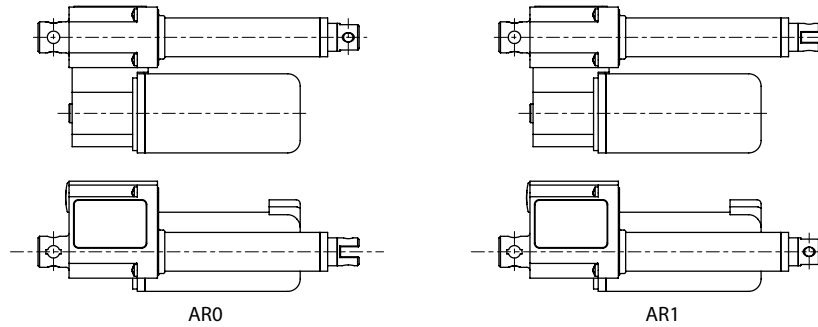

STROKE SETUP

Useful tips for handling stroke and avoid run-on-block collision

- When stroke is more than 350 mm, add 50 mm extra-stroke as guidance, and put corresponding value in ordering-key
- WARNING SPEED-TIMING ALONG STROKELENGTH: ramps are extremely important when speed is >30 mm/s!!! Inverter or PWM drive recommended!
- The more speed raises the more extra stroke has to raise too.

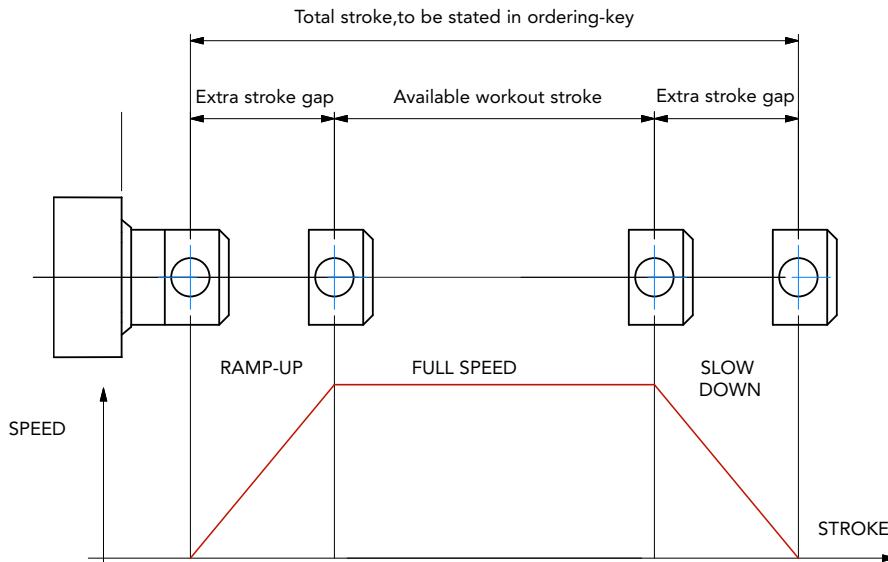

BUCKLING

When stroke is longer than 300mm, BUCKLING can be a risk: please check mounting with our offices and/or see usermanuals.

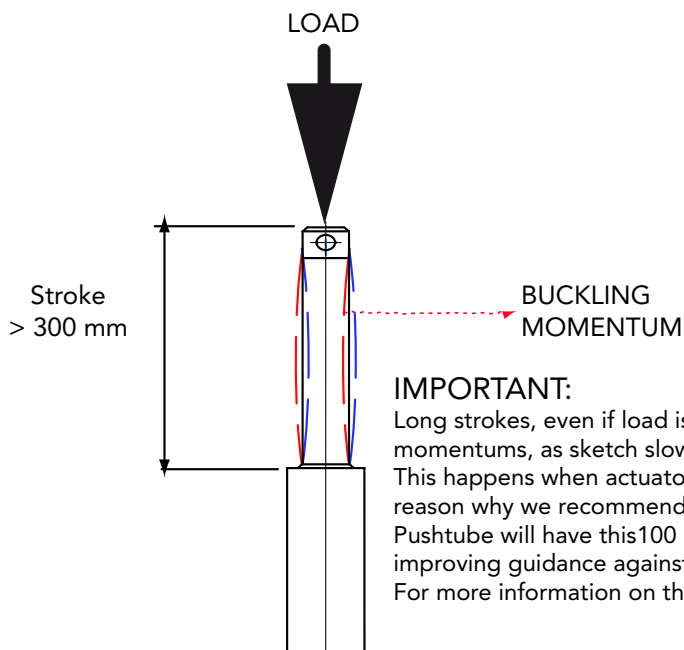

ALI1-PF/0250/M03/24/M0/C02/P1/A2/
MODEL

ALI1-P ALI1-P-F

STROKE (mm)

es. 250 mm = 0250

VERSION

 M01 / M02 / M03 / M04 / M05 / M06
 M00 = not standard speed

MOTOR

12 = 12 Vdc 24 = 24 Vdc

MOTOR POSITION

M0

MOTOR OPTIONS

- C01 / C08 Motor
 - C02 / C09 2LS Diode wired
 - C03 / C10 Motor + 2LS
 - C04 / C11 Motor + 3LS
 - C05 / C12 Motor + encoder
 - C06 / C13 2LS diode wired + encoder
 - C07 / C14 Motor + encoder + 2LS
 - C00 Special wiring (Presence of not standard options)
- Note: LS (limit switches)

REAR END

P0 = None P1/P2 = standard

FRONT END

A2 = Yoke A3 = Yoke + Clip A4 = Rod end A7 = M8x20 male

NOTE: COMPLETE THE ORDERING KEY ADDING THE OPTIONS YOU CAN FIND IN THE "ACCESSORIES AND OPTIONS" SECTION

P1 / P2

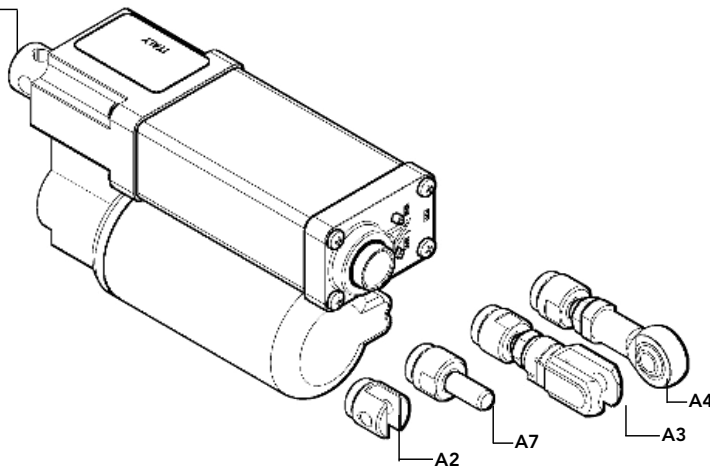
Note: "B" dimension changes according to model

 ALI1-F = See pictures
 ALI1-F stroke > 240 mm = + 13 mm
