

# EVB SERIES

An excellent choice for applications requiring high positional accuracy and dynamic performance. The EVB is a  $\leq 4$  arc-min gearbox that offers a right angle design with a through hole mounting style, making it compact and easy to assemble onto various equipment. This product is an ideal fit for various belt drive and actuator applications found throughout the packaging and assembly cell automation markets.

Various standard wash down and food grade options are available, making the EVB an attractive choice for the toughest environments. We offer the broadest selection of frame sizes and ratios, with immediate availability on most configurations. Industry standard mounting dimensions allow the EVB to be employed in legacy equipment designs, saving our customers time and money.

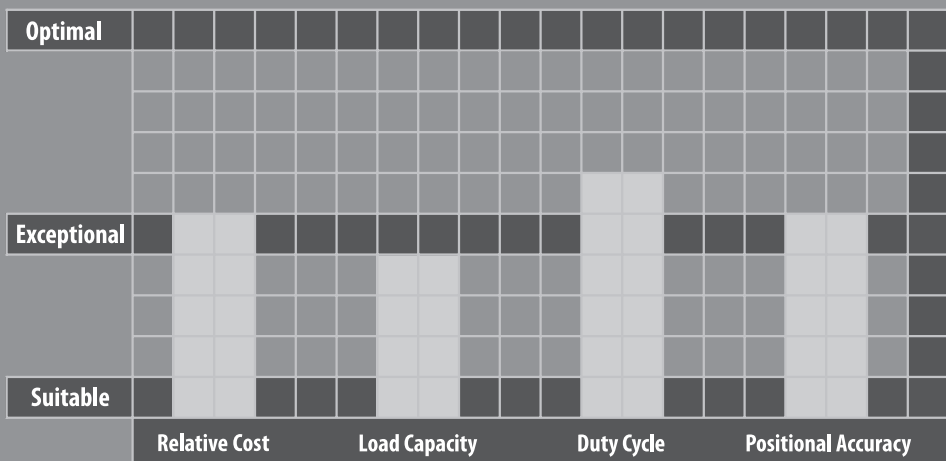

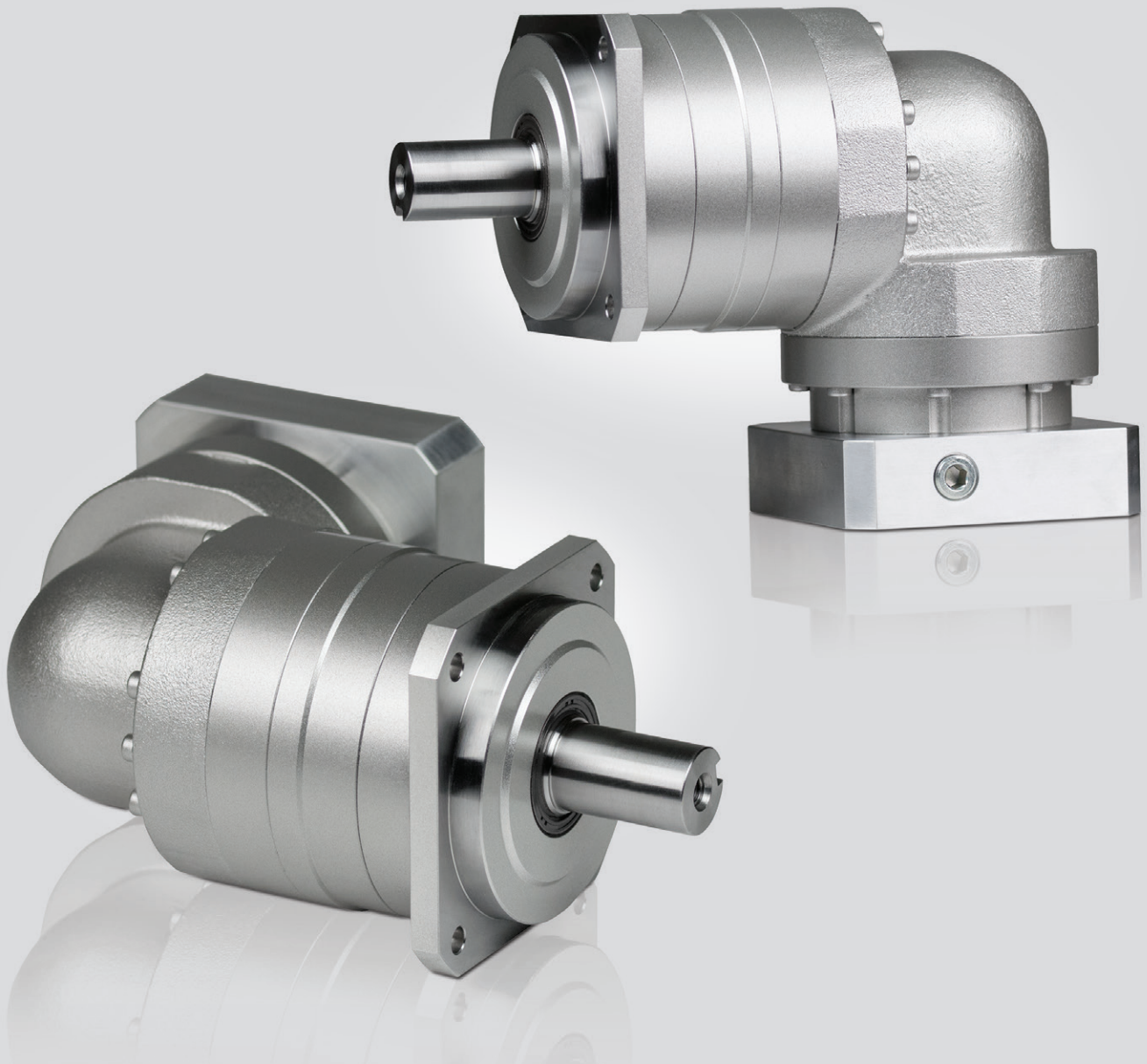

### EVB SERIES

- Compact, space-saving solution for mid to high end motion control applications
- The widest range of frame sizes and ratios available in the market
- Best-In-class backlash ( $\leq 4$  arc-min)
- Broad range of mounting adapters offer a simple, precise attachment to any motor
- Maintenance-free solution that is lubricated for life. High performance grease allows flexible mounting in any orientation
- Industry standard mounting dimensions
- Assembled in the USA

# EVB SERIES Right-angle Planetary

## EVB Series Features

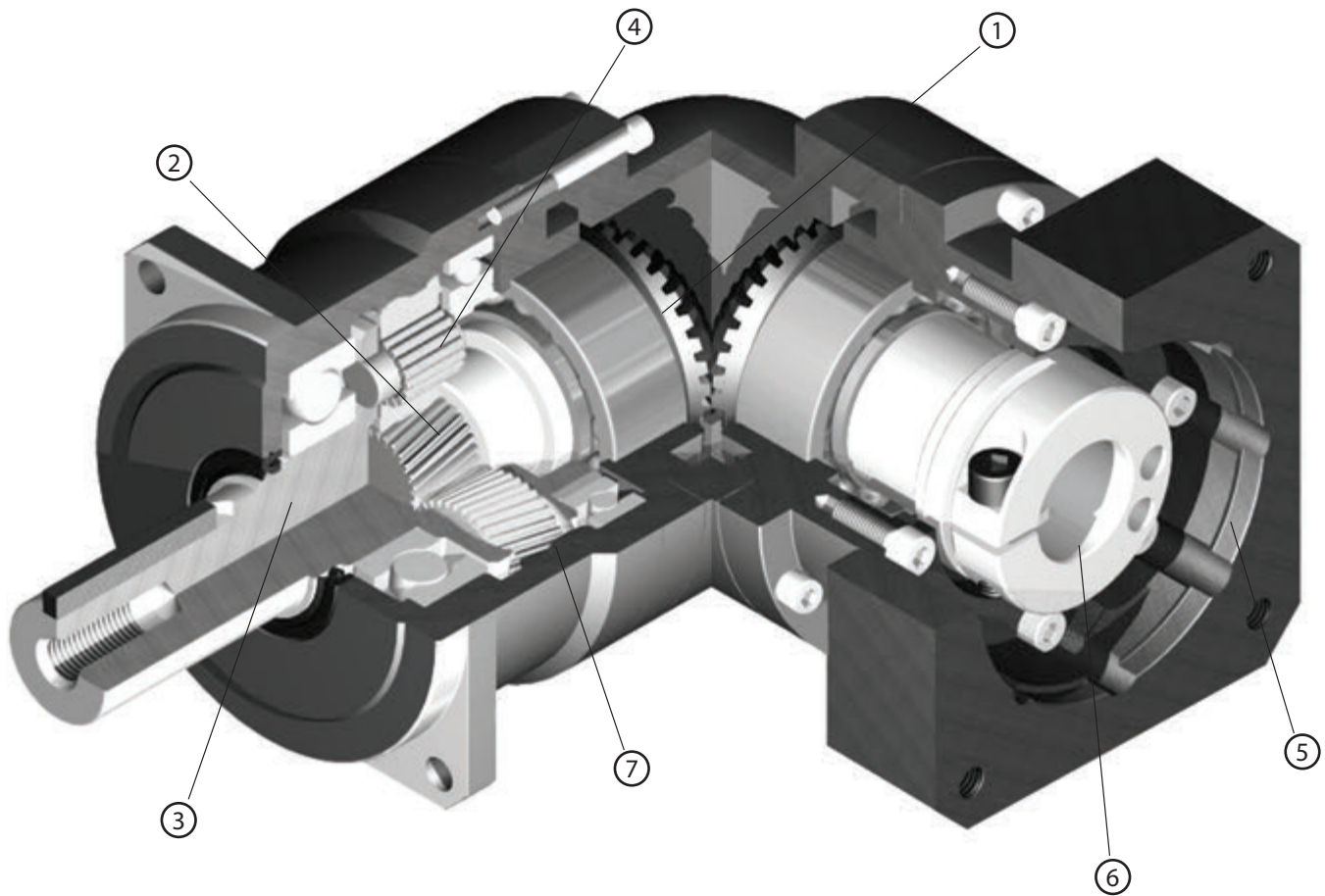

- ① Right angle bevel gear configuration allows motor to be mounted at a 90 degree position from the gearbox, saving space
- ② Carburized helical gears with proprietary secondary finishing process for higher accuracy and smooth, quiet operation. 40% higher tooth surface area than the industry standard
- ③ One piece output shaft and planet carrier with two bearings straddling the planet gears. Higher stiffness, torque capacity and safety factor, with guaranteed alignment of gearing
- ④ Uncaged needle roller bearings provide excellent torque density and torsional rigidity. 43% larger bearing surface area compared to the rest of the industry
- ⑤ Optimized mounting system with active centering on motor pilot diameter guarantees alignment of motor. Motor can be installed in any orientation
- ⑥ True concentric motor shaft clamping connection, optimized for your specific motor. Reduced inertia for dynamic performance and balanced for high speed operation
- ⑦ Ring gear machined directly into the housing, not welded or pressed in. Provides greater concentricity and elimination of speed fluctuation

## EVB Series Model Code

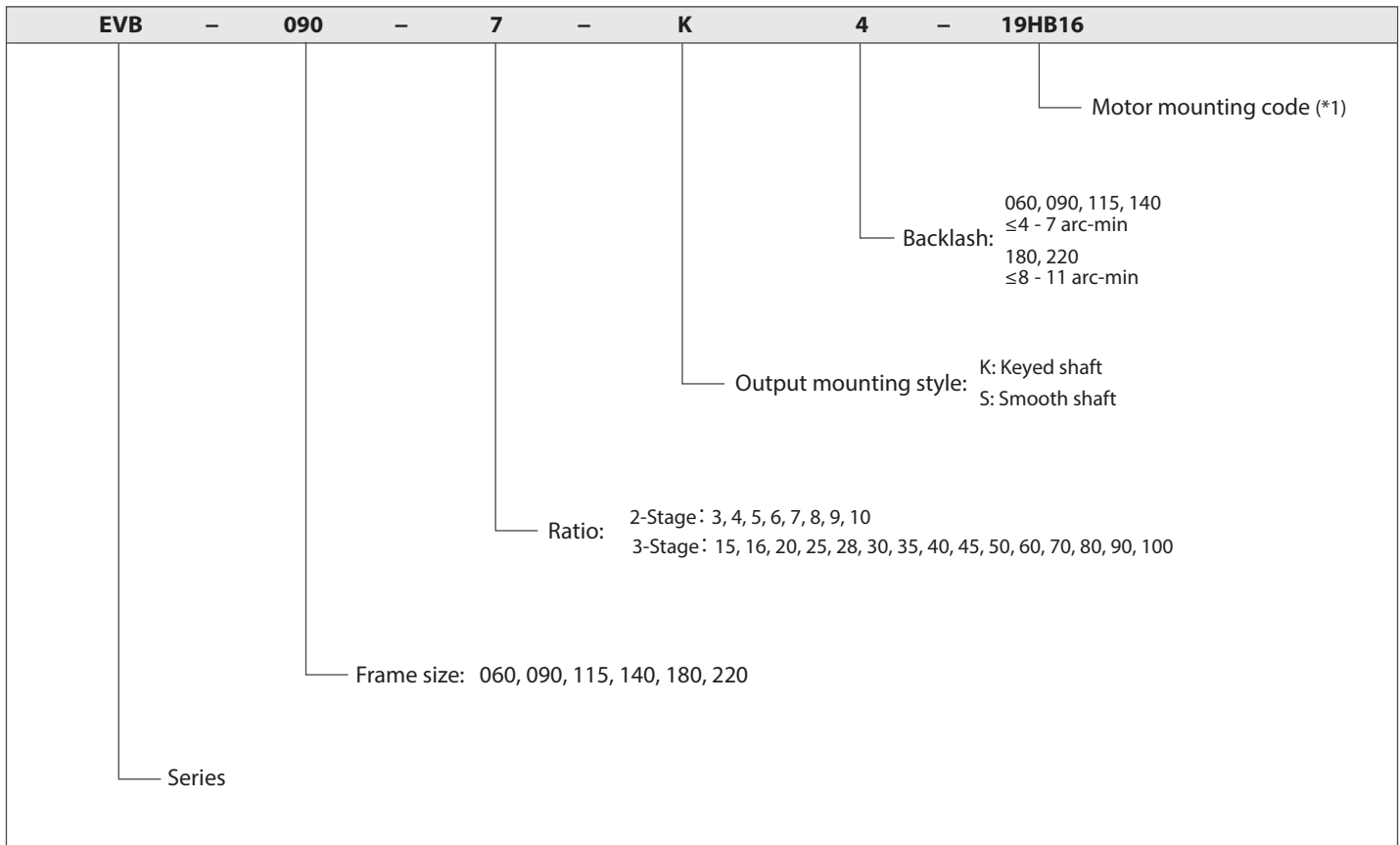

EVB

\*1) Motor mounting code varies depending on the motor. Use the selection tool link below to configure the code.

Contact us for additional information or refer to our online gearbox selection tool.  
Selection tool [www.nidec-shimpo.co.jp/selection/eng](http://www.nidec-shimpo.co.jp/selection/eng)

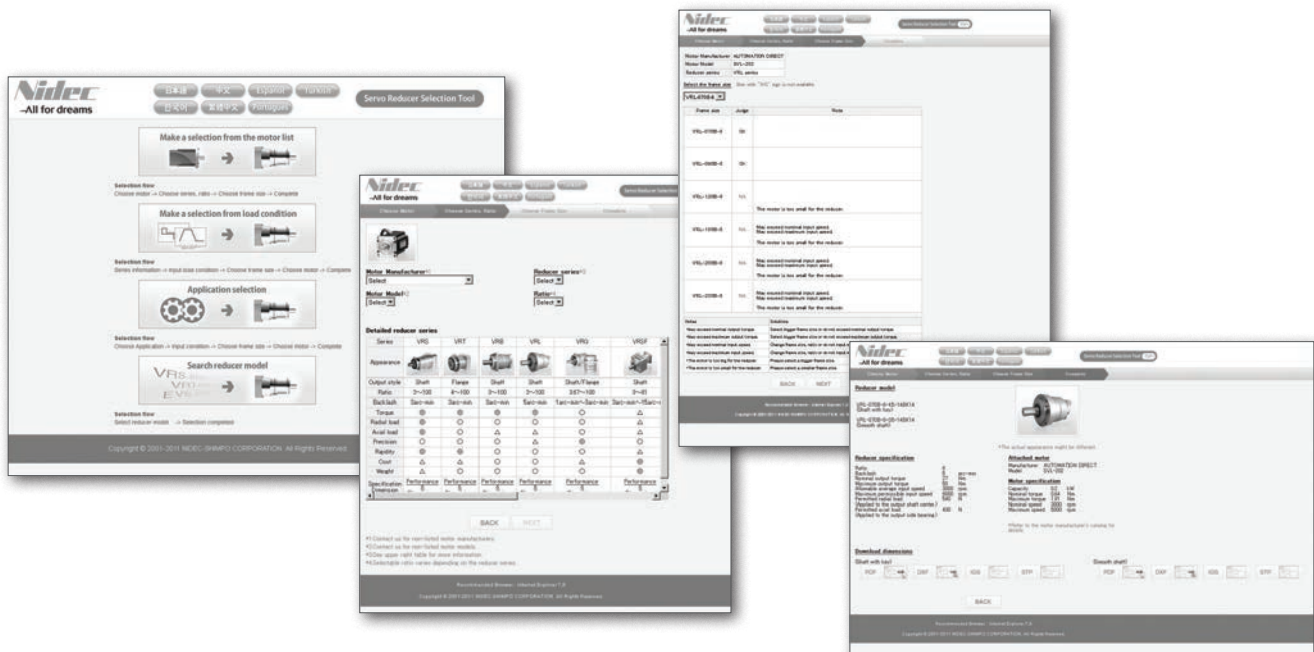

## EVB o6o 2-Stage Specifications

Frame Size	060									
Ratio	Unit	Note	3	4	5	6	7	8	9	10
Nominal Output Torque	[Nm]	*1	12	16	22	24	24	24	19	19
Maximum Acceleration Torque	[Nm]	*2	29	38	48	54	54	54	38	38
Maximum Torque	[Nm]	*3	33	45	56	63	63	61	45	45
Emergency Stop Torque	[Nm]	*4	50	65	80	90	90	90	65	65
Nominal Input Speed	[rpm]	*5	3300							
Maximum Input Speed	[rpm]	*6	6000							
No Load Running Torque	[Nm]	*7	0.33							
Maximum Radial Load	[N]	*8	1200							
Maximum Axial Load	[N]	*9	1100							
Moment of Inertia ( $\leq \varnothing 8$ )	[kgcm <sup>2</sup> ]	--	0.31	0.27	0.25	0.24	0.23	0.23	0.23	0.23
Moment of Inertia ( $\leq \varnothing 14$ )	[kgcm <sup>2</sup> ]	--	0.39	0.34	0.32	0.31	0.31	0.31	0.30	0.30
Moment of Inertia ( $\leq \varnothing 19$ )	[kgcm <sup>2</sup> ]	--	0.58	0.53	0.51	0.50	0.50	0.50	0.49	0.49
Efficiency	[%]	*10	93							
Torsional Rigidity	[Nm/arc-min]	*11	3							
Maximum Torsional Backlash	[arc-min]	--	$\leq 4$							
Noise Level	dB [A]	*12	$\leq 80$							
Protection Class	--	*13	IP54 (IP65)							
Ambient Temperature	[°C]	--	0-40							
Permitted Housing Temperature	[°C]	--	90							
Weight	[kg]	*14	1.8							

## EVB o6o 3-Stage Specifications

Frame Size	060									
Ratio	Unit	Note	15	16	20	25	28	30	35	40
Nominal Output Torque	[Nm]	*1	18	26	26	28	28	19	28	28
Maximum Acceleration Torque	[Nm]	*2	38	54	54	54	54	38	54	54
Maximum Torque	[Nm]	*3	38	54	54	54	54	38	54	54
Emergency Stop Torque	[Nm]	*4	65	90	90	90	90	65	90	90
Nominal Input Speed	[rpm]	*5	3800							
Maximum Input Speed	[rpm]	*6	6000							
No Load Running Torque	[Nm]	*7	0.20							
Maximum Radial Load	[N]	*8	1200							
Maximum Axial Load	[N]	*9	1100							
Moment of Inertia ( $\leq \varnothing 8$ )	[kgcm <sup>2</sup> ]	--	0.073	0.079	0.071	0.071	0.077	0.062	0.070	0.061
Moment of Inertia ( $\leq \varnothing 14$ )	[kgcm <sup>2</sup> ]	--	0.118	0.124	0.116	0.115	0.122	0.106	0.115	0.106
Moment of Inertia ( $\leq \varnothing 19$ )	[kgcm <sup>2</sup> ]	--	--	--	--	--			--	--
Efficiency	[%]	*10	88							
Torsional Rigidity	[Nm/arc-min]	*11	3							
Maximum Torsional Backlash	[arc-min]	--	$\leq 7$							
Noise Level	dB [A]	*12	$\leq 80$							
Protection Class	--	*13	IP54 (IP65)							
Ambient Temperature	[°C]	--	0-40							
Permitted Housing Temperature	[°C]	--	90							
Weight	[kg]	*14	1.6							

## EVB o6o 3-Stage Specifications

Frame Size	060										
Ratio	Unit	Note	45	50	60	70	80	90	100		
Nominal Output Torque	[Nm]	*1	19	28	28	28	28	19	19		
Maximum Acceleration Torque	[Nm]	*2	38	54	54	54	54	38	38		
Maximum Torque	[Nm]	*3	38	54	54	54	54	38	38		
Emergency Stop Torque	[Nm]	*4	65	90	90	90	90	65	65		
Nominal Input Speed	[rpm]	*5	3800								
Maximum Input Speed	[rpm]	*6	6000								
No Load Running Torque	[Nm]	*7	0.2								
Maximum Radial Load	[N]	*8	1200								
Maximum Axial Load	[N]	*9	1100								
Moment of Inertia ( $\leq \varnothing 8$ )	[kgcm <sup>2</sup> ]	--	0.070	0.061	0.061	0.061	0.061	0.061	0.061		
Moment of Inertia ( $\leq \varnothing 14$ )	[kgcm <sup>2</sup> ]	--	0.115	0.106	0.106	0.105	0.105	0.105	0.105		
Moment of Inertia ( $\leq \varnothing 19$ )	[kgcm <sup>2</sup> ]	--	--	--	--	--	--	--	--		
Efficiency	[%]	*10	88								
Torsional Rigidity	[Nm/arc-min]	*11	3								
Maximum Torsional Backlash	[arc-min]	--	$\leq 7$								
Noise Level	dB [A]	*12	$\leq 80$								
Protection Class	--	*13	IP54 (IP65)								
Ambient Temperature	[°C]	--	0-40								
Permitted Housing Temperature	[°C]	--	90								
Weight	[kg]	*14	1.6								

\*1) At nominal input speed, service life is 20,000 hours

\*2) The maximum torque when starting or stopping operation. Apply Cycle Factor  $f_0$ , found on page 468, for higher duty cycle applications

\*3) Permitted 10,000 times during service life. Based on 10% of maximum radial load and smooth output shaft

\*4) The maximum torque allowed under a stress situation. Permitted 1,000 times during service life

\*5) The average input speed at nominal input torque. Maintain housing temperature below permitted value

\*6) The maximum intermittent input speed

\*7) Torque at no load applied to the input shaft at nominal input speed

\*8) The maximum radial load that the gearbox can accept

\*9) The maximum axial load that the gearbox can accept

\*10) The efficiency at the nominal output torque rating

\*11) This does not include lost motion

\*12) Contact NIDEC-SHIMPO for the testing conditions and environment

\*13) Various wash-down options are available. Contact NIDEC-SHIMPO for more details

\*14) Weight may vary slightly between models

# EVB SERIES Right-angle Planetary

## EVB o6o 2-Stage Dimensions

Input bore size  $\leq \phi 8$  mm

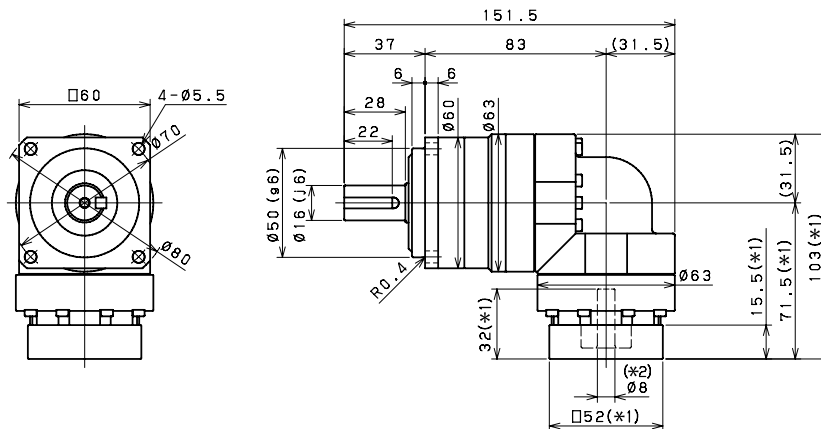

Input bore size  $\leq \phi 14$  mm

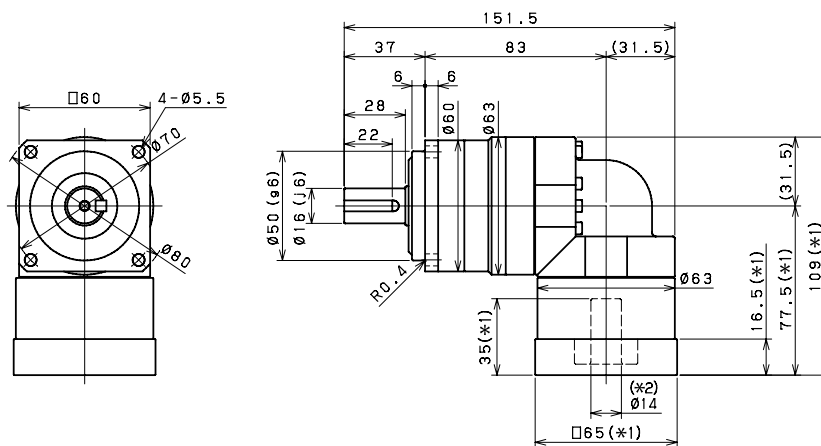

Input bore size  $\leq \phi 19$  mm

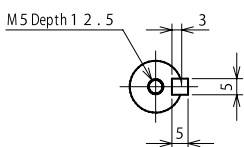
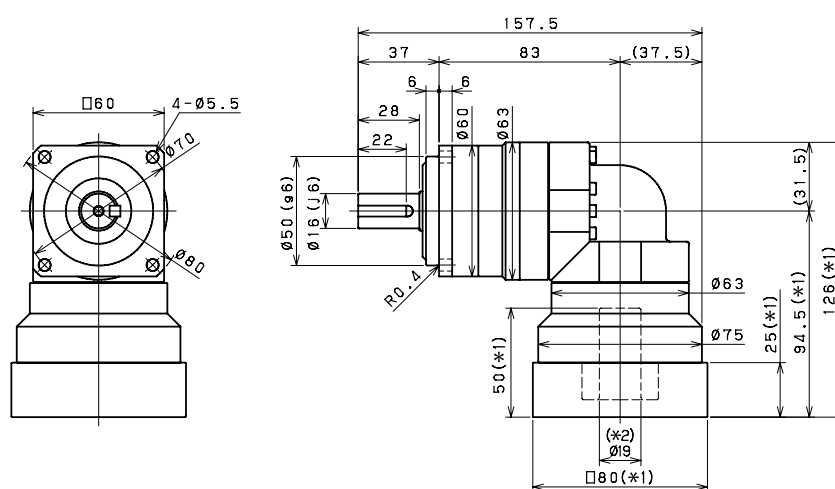

Keyed shaft

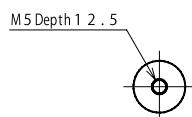

Smooth shaft

- \*1) Length will vary depending on motor
- \*2) Bushing will be inserted to adapt to motor shaft

## EVB o6o 3-Stage Dimensions

Input bore size  $\leq \phi 8$  mm

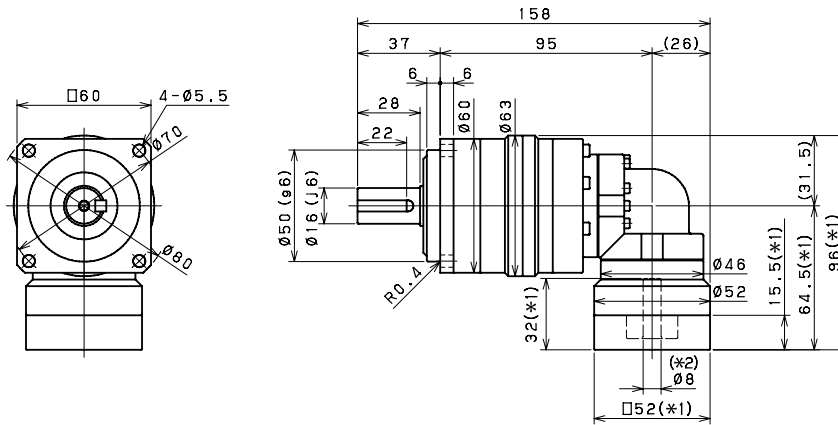

Input bore size  $\leq \phi 14$  mm

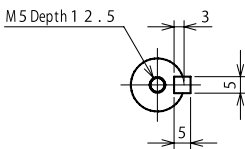
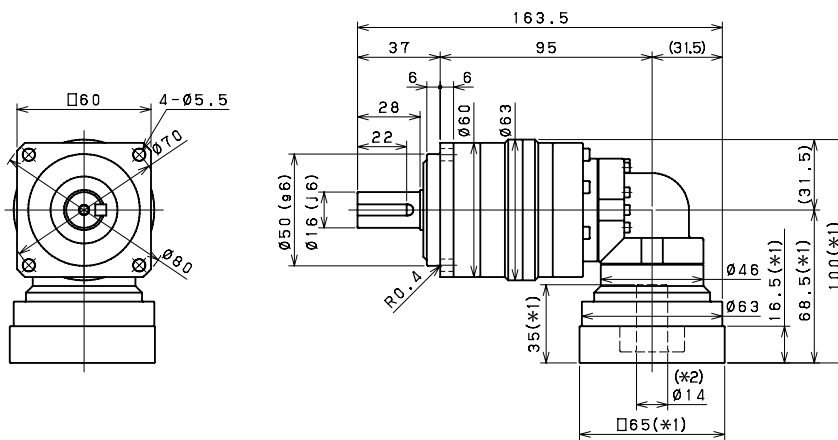

Keyed shaft

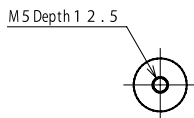

Smooth shaft

- \*1) Length will vary depending on motor
- \*2) Bushing will be inserted to adapt to motor shaft

EVB

## EVB 090 2-Stage Specifications

Frame Size	090									
Ratio	Unit	Note	3	4	5	6	7	8	9	10
Nominal Output Torque	[Nm]	*1	46	61	67	67	67	74	51	51
Maximum Acceleration Torque	[Nm]	*2	77	105	105	105	105	105	78	78
Maximum Torque	[Nm]	*3	90	121	121	119	119	117	93	93
Emergency Stop Torque	[Nm]	*4	130	170	220	220	220	220	170	170
Nominal Input Speed	[rpm]	*5	3000							
Maximum Input Speed	[rpm]	*6	6000							
No Load Running Torque	[Nm]	*7	1.13							
Maximum Radial Load	[N]	*8	2400							
Maximum Axial Load	[N]	*9	2200							
Moment of Inertia ( $\leq \varnothing 8$ )	[kgcm <sup>2</sup> ]	--	--	--	--	--	--	--	--	--
Moment of Inertia ( $\leq \varnothing 14$ )	[kgcm <sup>2</sup> ]	--	2.12	1.89	1.80	1.76	1.73	1.71	1.70	1.69
Moment of Inertia ( $\leq \varnothing 19$ )	[kgcm <sup>2</sup> ]	--	2.45	2.22	2.13	2.09	2.06	2.04	2.03	2.02
Moment of Inertia ( $\leq \varnothing 28$ )	[kgcm <sup>2</sup> ]	--	4.57	4.35	4.26	4.21	4.18	4.17	4.16	4.15
Efficiency	[%]	*10	93							
Torsional Rigidity	[Nm/arc-min]	*11	10							
Maximum Torsional Backlash	[arc-min]	--	$\leq 4$							
Noise Level	dB [A]	*12	$\leq 80$							
Protection Class	--	*13	IP54 (IP65)							
Ambient Temperature	[°C]	--	0-40							
Permitted Housing Temperature	[°C]	--	90							
Weight	[kg]	*14	5.1							

## EVB 090 3-Stage Specifications

Frame Size	090									
Ratio	Unit	Note	15	16	20	25	28	30	35	40
Nominal Output Torque	[Nm]	*1	43	66	68	72	78	47	73	78
Maximum Acceleration Torque	[Nm]	*2	77	128	128	128	128	77	128	128
Maximum Torque	[Nm]	*3	77	128	128	128	128	77	128	128
Emergency Stop Torque	[Nm]	*4	170	220	220	220	220	170	220	220
Nominal Input Speed	[rpm]	*5	3300							
Maximum Input Speed	[rpm]	*6	6000							
No Load Running Torque	[Nm]	*7	0.55							
Maximum Radial Load	[N]	*8	2400							
Maximum Axial Load	[N]	*9	2200							
Moment of Inertia ( $\leq \varnothing 8$ )	[kgcm <sup>2</sup> ]	--	0.34	0.38	0.33	0.32	0.37	0.25	0.32	0.25
Moment of Inertia ( $\leq \varnothing 14$ )	[kgcm <sup>2</sup> ]	--	0.41	0.46	0.40	0.40	0.45	0.33	0.4	0.32
Moment of Inertia ( $\leq \varnothing 19$ )	[kgcm <sup>2</sup> ]	--	0.6	0.65	0.59	0.59	0.64	0.51	0.59	0.51
Moment of Inertia ( $\leq \varnothing 28$ )	[kgcm <sup>2</sup> ]	--	--	--	--	--	--	--	--	--
Efficiency	[%]	*10	88							
Torsional Rigidity	[Nm/arc-min]	*11	10							
Maximum Torsional Backlash	[arc-min]	--	$\leq 7$							
Noise Level	dB [A]	*12	$\leq 80$							
Protection Class	--	*13	IP54 (IP65)							
Ambient Temperature	[°C]	--	0-40							
Permitted Housing Temperature	[°C]	--	90							
Weight	[kg]	*14	4.4							

## EVB 090 3-Stage Specifications

Frame Size	090										
Ratio	Unit	Note	45	50	60	70	80	90	100		
Nominal Output Torque	[Nm]	*1	47	73	73	73	78	52	52		
Maximum Acceleration Torque	[Nm]	*2	78	128	128	128	128	78	78		
Maximum Torque	[Nm]	*3	78	128	128	128	128	78	78		
Emergency Stop Torque	[Nm]	*4	170	220	220	220	220	170	170		
Nominal Input Speed	[rpm]	*5	3300								
Maximum Input Speed	[rpm]	*6	6000								
No Load Running Torque	[Nm]	*7	0.55								
Maximum Radial Load	[N]	*8	2400								
Maximum Axial Load	[N]	*9	2200								
Moment of Inertia ( $\leq \varnothing 8$ )	[kgcm <sup>2</sup> ]	--	0.32	0.25	0.25	0.25	0.25	0.25	0.25		
Moment of Inertia ( $\leq \varnothing 14$ )	[kgcm <sup>2</sup> ]	--	0.39	0.32	0.32	0.32	0.32	0.32	0.32		
Moment of Inertia ( $\leq \varnothing 19$ )	[kgcm <sup>2</sup> ]	--	0.58	0.51	0.51	0.51	0.51	0.51	0.51		
Moment of Inertia ( $\leq \varnothing 28$ )	[kgcm <sup>2</sup> ]	--	--	--	--	--	--	--	--		
Efficiency	[%]	*10	88								
Torsional Rigidity	[Nm/arc-min]	*11	10								
Maximum Torsional Backlash	[arc-min]	--	$\leq 7$								
Noise Level	dB [A]	*12	$\leq 80$								
Protection Class	--	*13	IP54 (IP65)								
Ambient Temperature	[°C]	--	0-40								
Permitted Housing Temperature	[°C]	--	90								
Weight	[kg]	*14	4.4								

\*1) At nominal input speed, service life is 20,000 hours

\*2) The maximum torque when starting or stopping operation. Apply Cycle Factor  $f_0$ , found on page 468, for higher duty cycle applications

\*3) Permitted 10,000 times during service life. Based on 10% of maximum radial load and smooth output shaft

\*4) The maximum torque allowed under a stress situation. Permitted 1,000 times during service life

\*5) The average input speed at nominal input torque. Maintain housing temperature below permitted value

\*6) The maximum intermittent input speed

\*7) Torque at no load applied to the input shaft at nominal input speed

\*8) The maximum radial load that the gearbox can accept

\*9) The maximum axial load that the gearbox can accept

\*10) The efficiency at the nominal output torque rating

\*11) This does not include lost motion

\*12) Contact NIDEC-SHIMPO for the testing conditions and environment

\*13) Various wash-down options are available. Contact NIDEC-SHIMPO for more details

\*14) Weight may vary slightly between models

# EVB SERIES Right-angle Planetary

## EVB 090 2-Stage Dimensions

Input bore size  $\leq \varnothing 14$  mm

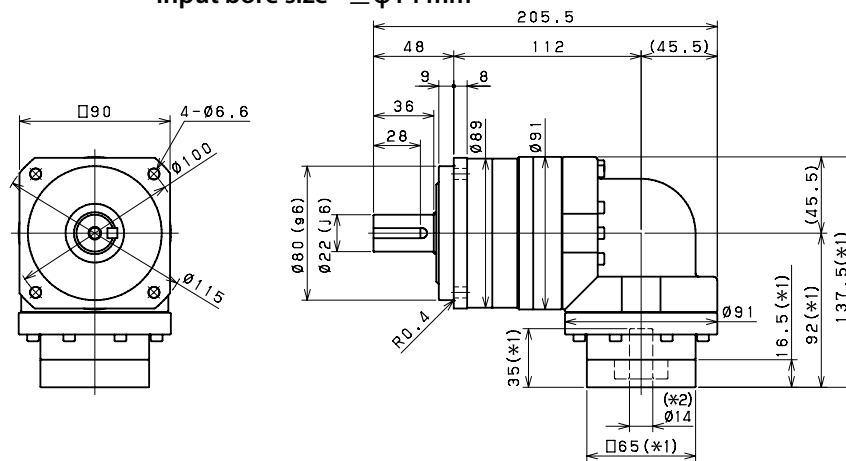

Input bore size  $\leq \varnothing 19$  mm

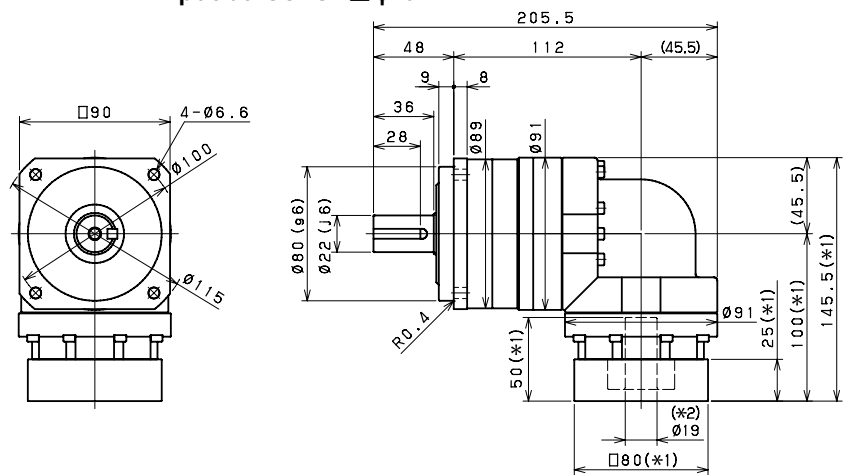

Input bore size  $\leq \varnothing 28$  mm

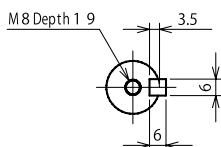
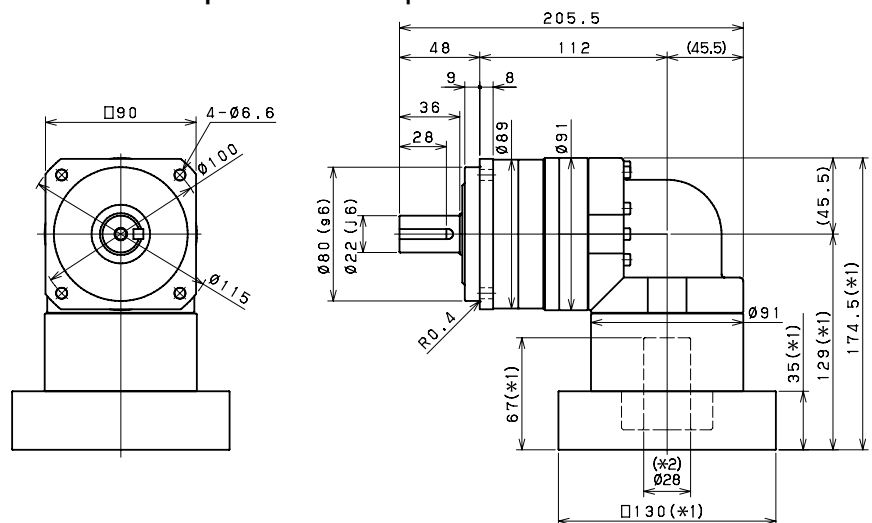

Keyed shaft

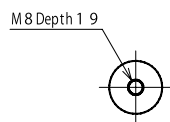

Smooth shaft

\*1) Length will vary depending on motor

\*2) Bushing will be inserted to adapt to motor shaft

## EVB 090 3-Stage Dimensions

Input bore size  $\leq \varnothing 8 \text{ mm}$

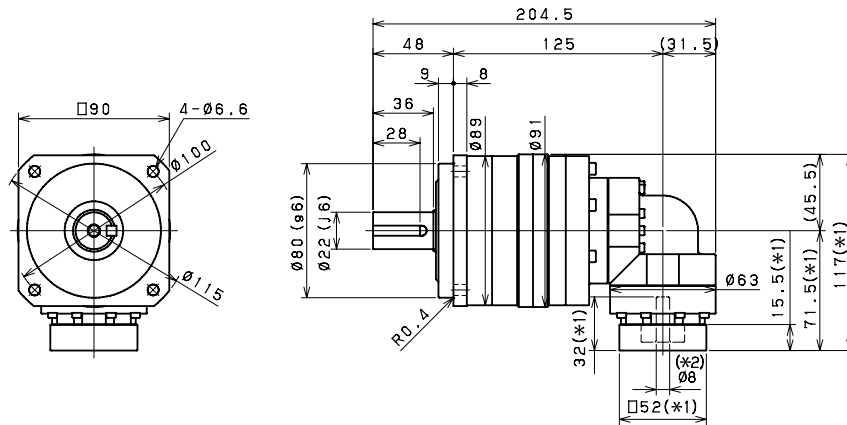

Input bore size  $\leq \varnothing 14 \text{ mm}$

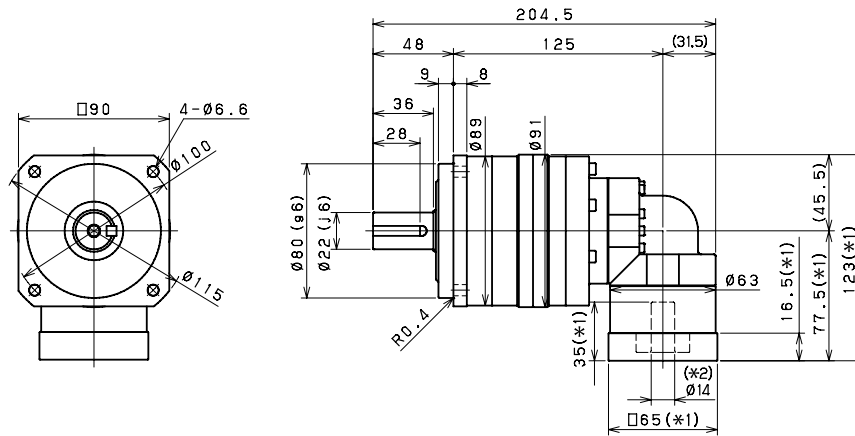

Input bore size  $\leq \varnothing 19 \text{ mm}$

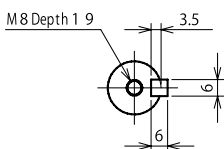
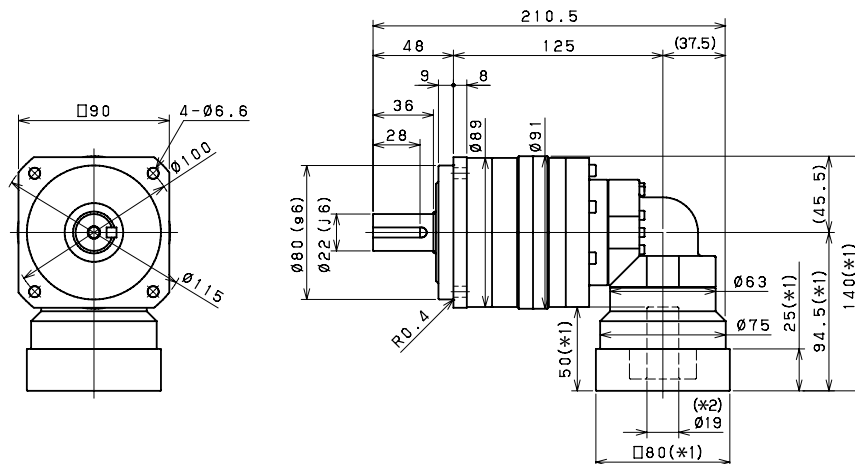

Keyed shaft

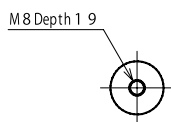

Smooth shaft

\*1) Length will vary depending on motor

\*2) Bushing will be inserted to adapt to motor shaft

EVB

## EVB 115 2-Stage Specifications

Frame Size	115									
Ratio	Unit	Note	3	4	5	6	7	8	9	10
Nominal Output Torque	[Nm]	*1	77	108	123	154	154	154	128	128
Maximum Acceleration Torque	[Nm]	*2	172	227	272	340	340	340	240	240
Maximum Torque	[Nm]	*3	205	271	325	401	401	401	288	288
Emergency Stop Torque	[Nm]	*4	320	430	500	550	550	550	450	450
Nominal Input Speed	[rpm]	*5	3000							
Maximum Input Speed	[rpm]	*6	6000							
No Load Running Torque	[Nm]	*7	1.88							
Maximum Radial Load	[N]	*8	4300							
Maximum Axial Load	[N]	*9	3900							
Moment of Inertia ( $\leq \varnothing 14$ )	[kgcm <sup>2</sup> ]	--	--	--	--	--	--	--	--	--
Moment of Inertia ( $\leq \varnothing 19$ )	[kgcm <sup>2</sup> ]	--	6.74	5.49	5.02	4.77	4.65	4.55	4.49	4.46
Moment of Inertia ( $\leq \varnothing 28$ )	[kgcm <sup>2</sup> ]	--	8.34	7.08	6.61	6.36	6.24	6.14	6.08	6.05
Moment of Inertia ( $\leq \varnothing 38$ )	[kgcm <sup>2</sup> ]	--	15.41	14.15	13.69	13.43	13.31	13.22	13.16	13.12
Efficiency	[%]	*10	93							
Torsional Rigidity	[Nm/arc-min]	*11	31							
Maximum Torsional Backlash	[arc-min]	--	$\leq 4$							
Noise Level	dB [A]	*12	$\leq 85$							
Protection Class	--	*13	IP54 (IP65)							
Ambient Temperature	[°C]	--	0-40							
Permitted Housing Temperature	[°C]	--	90							
Weight	[kg]	*14	10.4							

## EVB 115 3-Stage Specifications

Frame Size	115									
Ratio	Unit	Note	15	16	20	25	28	30	35	40
Nominal Output Torque	[Nm]	*1	125	136	162	174	174	132	174	172
Maximum Acceleration Torque	[Nm]	*2	229	295	340	340	340	229	340	340
Maximum Torque	[Nm]	*3	229	295	340	340	340	229	340	340
Emergency Stop Torque	[Nm]	*4	450	550	550	550	550	450	550	550
Nominal Input Speed	[rpm]	*5	3100							
Maximum Input Speed	[rpm]	*6	6000							
No Load Running Torque	[Nm]	*7	1.11							
Maximum Radial Load	[N]	*8	3900							
Maximum Axial Load	[N]	*9	3900							
Moment of Inertia ( $\leq \varnothing 14$ )	[kgcm <sup>2</sup> ]	--	2.25	2.46	2.20	2.18	2.40	1.87	2.16	1.86
Moment of Inertia ( $\leq \varnothing 19$ )	[kgcm <sup>2</sup> ]	--	2.58	2.79	2.53	2.51	2.73	2.20	2.49	2.19
Moment of Inertia ( $\leq \varnothing 28$ )	[kgcm <sup>2</sup> ]	--	4.70	4.91	4.65	4.64	4.86	4.33	4.62	4.32
Moment of Inertia ( $\leq \varnothing 38$ )	[kgcm <sup>2</sup> ]	--	--	--	--	--	--	--	--	--
Efficiency	[%]	*10	88							
Torsional Rigidity	[Nm/arc-min]	*11	31							
Maximum Torsional Backlash	[arc-min]	--	$\leq 7$							
Noise Level	dB [A]	*12	$\leq 85$							
Protection Class	--	*13	IP54 (IP65)							
Ambient Temperature	[°C]	--	0-40							
Permitted Housing Temperature	[°C]	--	90							
Weight	[kg]	*14	10.1							

## EVB 115 3-Stage Specifications

Frame Size	115										
Ratio	Unit	Note	45	50	60	70	80	90	100		
Nominal Output Torque	[Nm]	*1	132	174	174	174	174	132	132		
Maximum Acceleration Torque	[Nm]	*2	240	340	340	340	340	240	240		
Maximum Torque	[Nm]	*3	240	340	340	340	340	240	240		
Emergency Stop Torque	[Nm]	*4	450	550	550	550	550	450	450		
Nominal Input Speed	[rpm]	*5	3100								
Maximum Input Speed	[rpm]	*6	6000								
No Load Running Torque	[Nm]	*7	1.11								
Maximum Radial Load	[N]	*8	4300								
Maximum Axial Load	[N]	*9	3900								
Moment of Inertia ( $\leq \varnothing 14$ )	[kgcm <sup>2</sup> ]	--	2.15	1.86	1.85	1.85	1.85	1.85	1.85		
Moment of Inertia ( $\leq \varnothing 19$ )	[kgcm <sup>2</sup> ]	--	2.48	2.19	2.18	2.18	2.18	2.18	2.18		
Moment of Inertia ( $\leq \varnothing 28$ )	[kgcm <sup>2</sup> ]	--	4.61	4.31	4.31	4.31	4.31	4.31	4.31		
Moment of Inertia ( $\leq \varnothing 38$ )	[kgcm <sup>2</sup> ]	--	--	--	--	--	--	--	--		
Efficiency	[%]	*10	88								
Torsional Rigidity	[Nm/arc-min]	*11	31								
Maximum Torsional Backlash	[arc-min]	--	$\leq 7$								
Noise Level	dB [A]	*12	$\leq 85$								
Protection Class	--	*13	IP54 (IP65)								
Ambient Temperature	[°C]	--	0-40								
Permitted Housing Temperature	[°C]	--	90								
Weight	[kg]	*14	10.1								

\*1) At nominal input speed, service life is 20,000 hours

\*2) The maximum torque when starting or stopping operation. Apply Cycle Factor  $f_0$ , found on page 468, for higher duty cycle applications

\*3) Permitted 10,000 times during service life. Based on 10% of maximum radial load and smooth output shaft

\*4) The maximum torque allowed under a stress situation. Permitted 1,000 times during service life

\*5) The average input speed at nominal input torque. Maintain housing temperature below permitted value

\*6) The maximum intermittent input speed

\*7) Torque at no load applied to the input shaft at nominal input speed

\*8) The maximum radial load that the gearbox can accept

\*9) The maximum axial load that the gearbox can accept

\*10) The efficiency at the nominal output torque rating

\*11) This does not include lost motion

\*12) Contact NIDEC-SHIMPO for the testing conditions and environment

\*13) Various wash-down options are available. Contact NIDEC-SHIMPO for more details

\*14) Weight may vary slightly between models

# EVB SERIES Right-angle Planetary

## EVB 115 2-Stage Dimensions

Input bore size  $\leq \phi 19$  mm

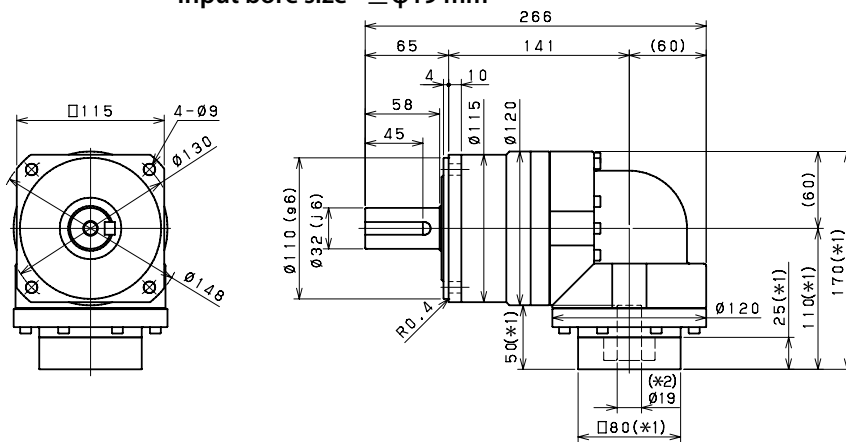

Input bore size  $\leq \phi 28$  mm

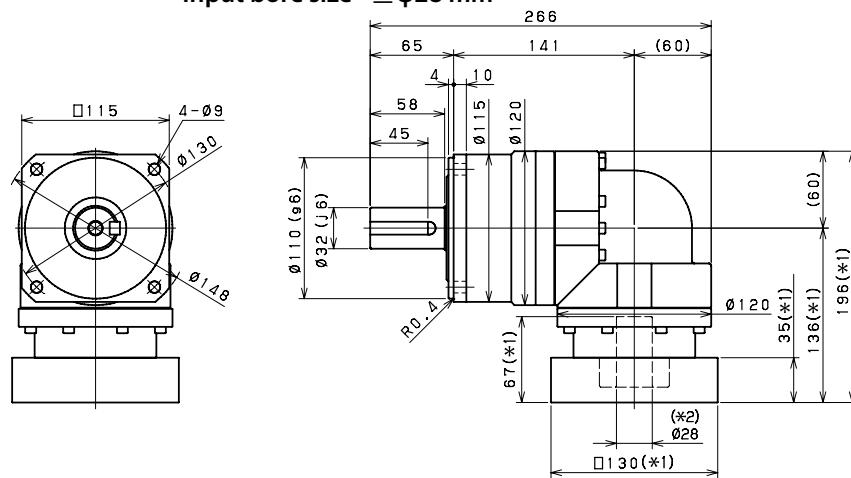

Input bore size  $\leq \phi 38$  mm

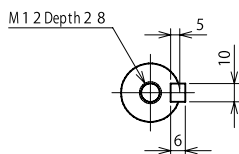
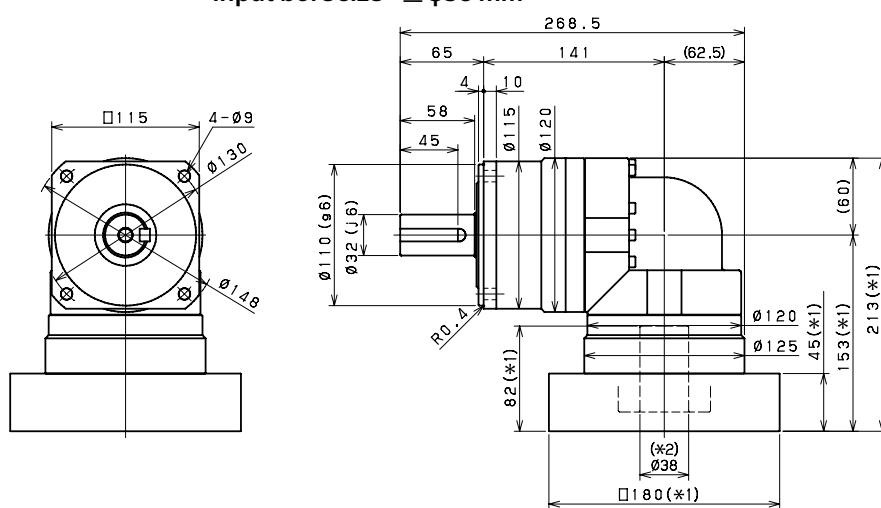

Keyed shaft

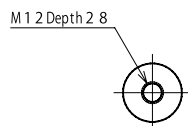

Smooth shaft

- \*1) Length will vary depending on motor
- \*2) Bushing will be inserted to adapt to motor shaft

## EVB 115 3-Stage Dimensions

Input bore size  $\leq \phi 14$  mm

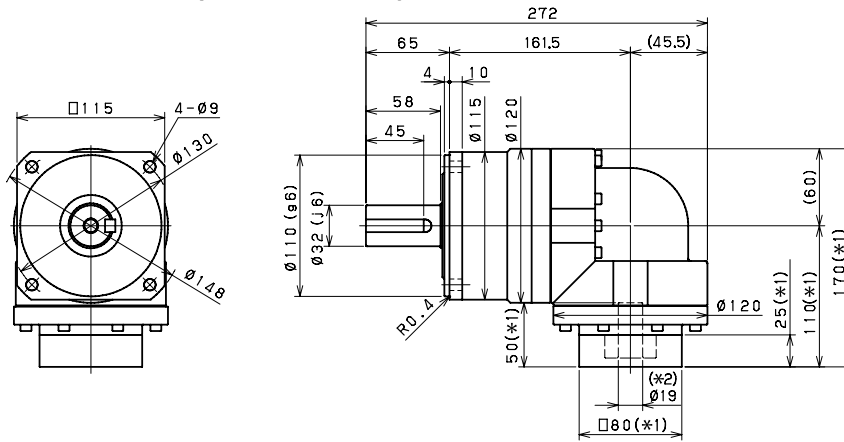

Input bore size  $\leq \phi 19$  mm

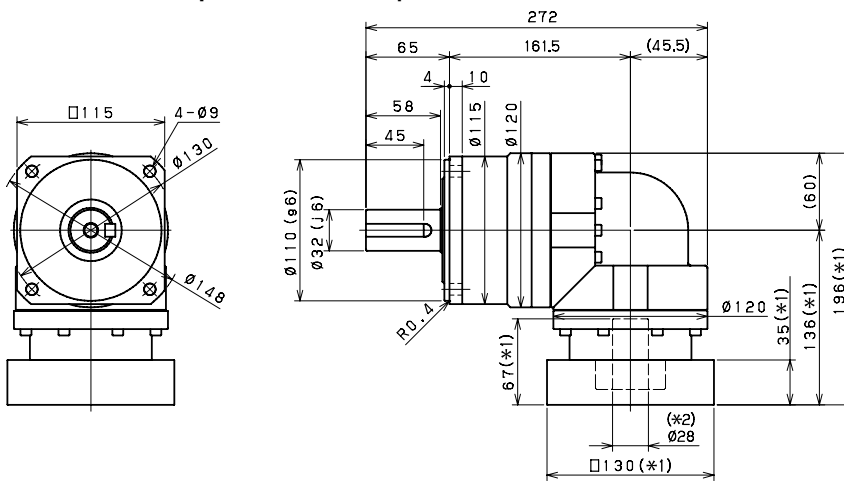

Input bore size  $\leq \phi 28$  mm

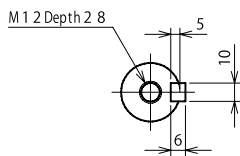
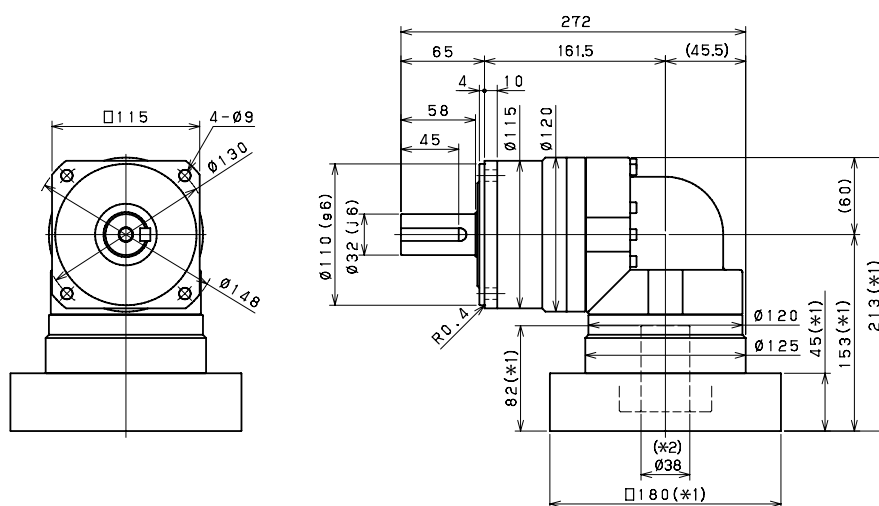

Keyed shaft

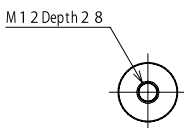

Smooth shaft

\*1) Length will vary depending on motor

\*2) Bushing will be inserted to adapt to motor shaft

## EVB 140 2-Stage Specifications

Frame Size	140									
Ratio	Unit	Note	3	4	5	6	7	8	9	10
Nominal Output Torque	[Nm]	*1	132	181	205	266	307	307	233	233
Maximum Acceleration Torque	[Nm]	*2	296	389	458	595	687	687	480	480
Maximum Torque	[Nm]	*3	329	452	531	664	766	766	559	559
Emergency Stop Torque	[Nm]	*4	700	950	1100	1100	1100	1100	750	750
Nominal Input Speed	[rpm]	*5	2000							
Maximum Input Speed	[rpm]	*6	4000							
No Load Running Torque	[Nm]	*7	3.26							
Maximum Radial Load	[N]	*8	9100							
Maximum Axial Load	[N]	*9	8200							
Moment of Inertia ( $\leq \varnothing 19$ )	[kgcm <sup>2</sup> ]	--	--	--	--	--	--	--	--	--
Moment of Inertia ( $\leq \varnothing 28$ )	[kgcm <sup>2</sup> ]	--	23.13	18.57	16.91	16.01	15.58	15.23	14.77	14.66
Moment of Inertia ( $\leq \varnothing 38$ )	[kgcm <sup>2</sup> ]	--	27.50	22.94	21.28	20.38	19.95	19.61	19.41	19.03
Moment of Inertia ( $\leq \varnothing 48$ )	[kgcm <sup>2</sup> ]	--	40.73	36.17	34.51	33.61	33.18	32.84	32.37	32.26
Efficiency	[%]	*10	93							
Torsional Rigidity	[Nm/arc-min]	*11	60							
Maximum Torsional Backlash	[arc-min]	--	$\leq 4$							
Noise Level	dB [A]	*12	$\leq 85$							
Protection Class	--	*13	IP54 (IP65)							
Ambient Temperature	[°C]	--	0-40							
Permitted Housing Temperature	[°C]	--	90							
Weight	[kg]	*14	19.1							

## EVB 140 3-Stage Specifications

Frame Size	140									
Ratio	Unit	Note	15	16	20	25	28	30	35	40
Nominal Output Torque	[Nm]	*1	230	307	316	352	352	240	352	337
Maximum Acceleration Torque	[Nm]	*2	456	687	687	687	687	456	687	687
Maximum Torque	[Nm]	*3	456	687	687	687	687	456	687	687
Emergency Stop Torque	[Nm]	*4	750	1100	1100	1100	1100	750	1100	1100
Nominal Input Speed	[rpm]	*5	2300							
Maximum Input Speed	[rpm]	*6	4000							
No Load Running Torque	[Nm]	*7	2.56							
Maximum Radial Load	[N]	*8	9100							
Maximum Axial Load	[N]	*9	8200							
Moment of Inertia ( $\leq \varnothing 19$ )	[kgcm <sup>2</sup> ]	--	6.40	7.29	6.22	6.15	7.09	4.99	6.09	4.95
Moment of Inertia ( $\leq \varnothing 28$ )	[kgcm <sup>2</sup> ]	--	8	8.88	7.81	7.75	8.68	6.58	7.69	6.54
Moment of Inertia ( $\leq \varnothing 38$ )	[kgcm <sup>2</sup> ]	--	15.07	15.96	14.89	14.82	15.76	13.66	14.76	13.61
Moment of Inertia ( $\leq \varnothing 48$ )	[kgcm <sup>2</sup> ]	--	--	--	--	--	--	--	--	--
Efficiency	[%]	*10	88							
Torsional Rigidity	[Nm/arc-min]	*11	60							
Maximum Torsional Backlash	[arc-min]	--	$\leq 7$							
Noise Level	dB [A]	*12	$\leq 85$							
Protection Class	--	*13	IP54 (IP65)							
Ambient Temperature	[°C]	--	0-40							
Permitted Housing Temperature	[°C]	--	90							
Weight	[kg]	*14	19.6							

## EVB 140 3-Stage Specifications

Frame Size	140										
Ratio	Unit	Note	45	50	60	70	80	90	100		
Nominal Output Torque	[Nm]	*1	240	352	352	352	352	240	240		
Maximum Acceleration Torque	[Nm]	*2	480	687	687	687	687	480	480		
Maximum Torque	[Nm]	*3	480	687	687	687	687	480	480		
Emergency Stop Torque	[Nm]	*4	750	1100	1100	1100	1100	750	750		
Nominal Input Speed	[rpm]	*5	2300								
Maximum Input Speed	[rpm]	*6	4000								
No Load Running Torque	[Nm]	*7	2.56								
Maximum Radial Load	[N]	*8	9100								
Maximum Axial Load	[N]	*9	8200								
Moment of Inertia (≤ Ø 19)	[kgcm <sup>2</sup> ]	--	6.07	4.93	4.92	4.91	4.91	4.91	4.91		
Moment of Inertia (≤ Ø 28)	[kgcm <sup>2</sup> ]	--	7.66	6.52	6.51	6.51	6.50	6.50	6.50		
Moment of Inertia (≤ Ø 38)	[kgcm <sup>2</sup> ]	--	14.74	13.59	13.59	13.58	13.58	13.57	13.57		
Moment of Inertia (≤ Ø 48)	[kgcm <sup>2</sup> ]	--	--	--	--	--	--	--	--		
Efficiency	[%]	*10	88								
Torsional Rigidity	[Nm/arc-min]	*11	60								
Maximum Torsional Backlash	[arc-min]	--	≤ 7								
Noise Level	dB [A]	*12	≤ 85								
Protection Class	--	*13	IP54 (IP65)								
Ambient Temperature	[°C]	--	0-40								
Permitted Housing Temperature	[°C]	--	90								
Weight	[kg]	*14	19.6								

\*1) At nominal input speed, service life is 20,000 hours

\*2) The maximum torque when starting or stopping operation. Apply Cycle Factor  $f_0$ , found on page 468, for higher duty cycle applications

\*3) Permitted 10,000 times during service life. Based on 10% of maximum radial load and smooth output shaft

\*4) The maximum torque allowed under a stress situation. Permitted 1,000 times during service life

\*5) The average input speed at nominal input torque. Maintain housing temperature below permitted value

\*6) The maximum intermittent input speed

\*7) Torque at no load applied to the input shaft at nominal input speed

\*8) The maximum radial load that the gearbox can accept

\*9) The maximum axial load that the gearbox can accept

\*10) The efficiency at the nominal output torque rating

\*11) This does not include lost motion

\*12) Contact NIDEC-SHIMPO for the testing conditions and environment

\*13) Various wash-down options are available. Contact NIDEC-SHIMPO for more details

\*14) Weight may vary slightly between models

# EVB SERIES Right-angle Planetary

## EVB 140 2-Stage Dimensions

Input bore size  $\leq \varnothing 28$  mm

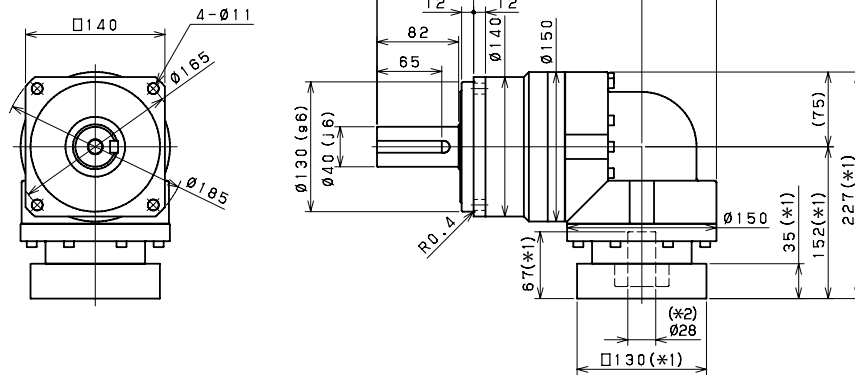

Input bore size  $\leq \varnothing 38$  mm

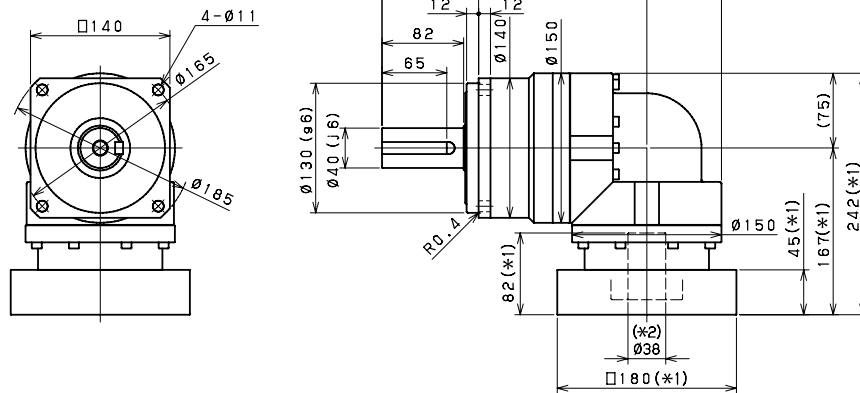

Input bore size  $\leq \varnothing 48$  mm

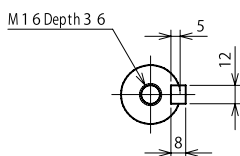
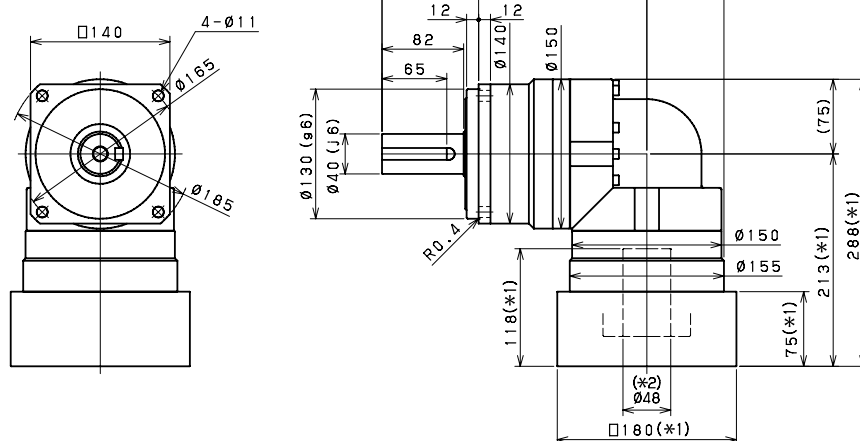

Keyed shaft

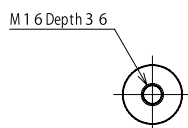

Smooth shaft

\*1) Length will vary depending on motor

\*2) Bushing will be inserted to adapt to motor shaft

## EVB 140 3-Stage Dimensions

Input bore size  $\leq \phi 19$  mm

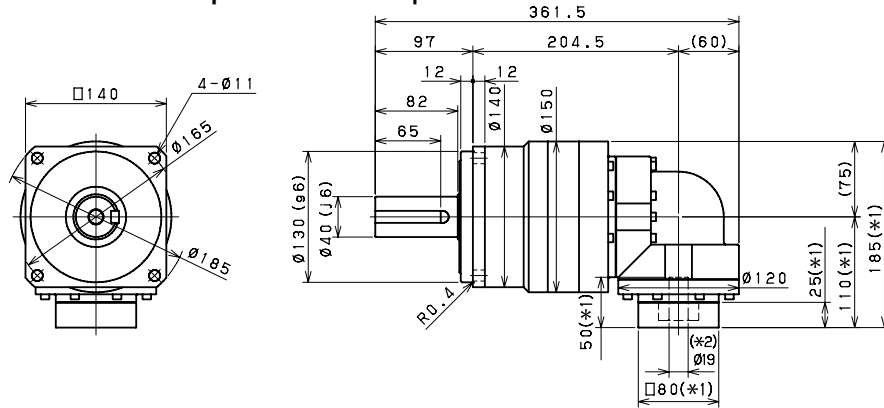

Input bore size  $\leq \phi 28$  mm

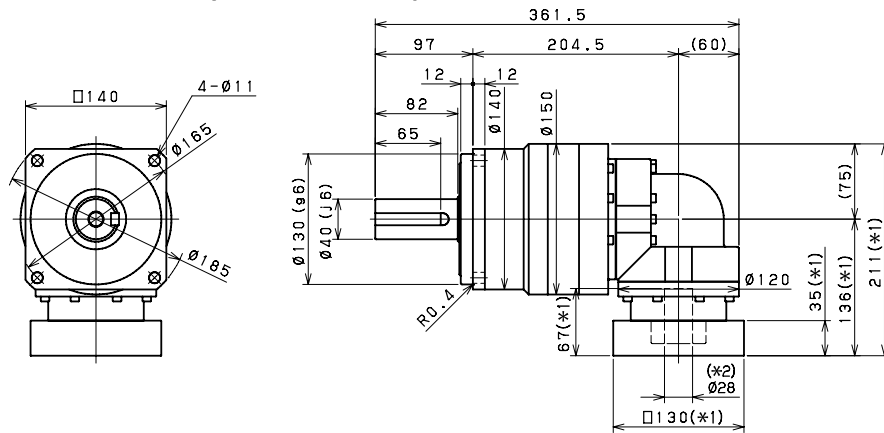

Input bore size  $\leq \phi 38$  mm

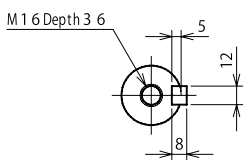
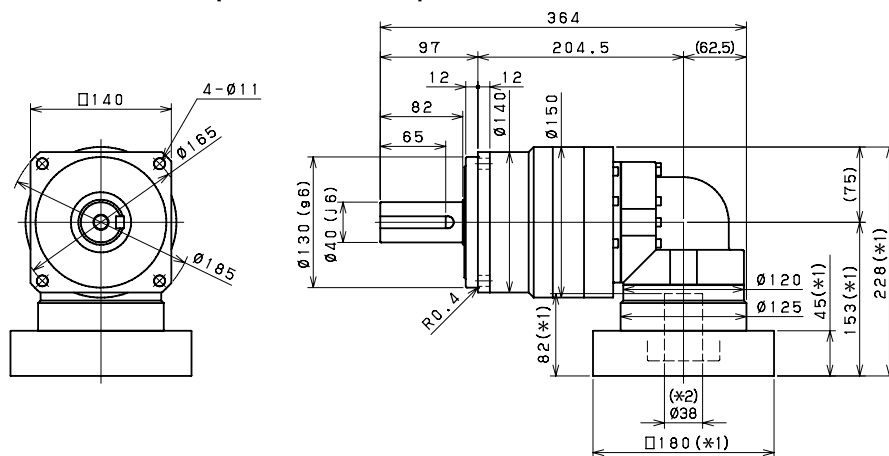

Keyed shaft

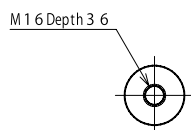

Smooth shaft

\*1) Length will vary depending on motor

\*2) Bushing will be inserted to adapt to motor shaft

EVB

## EVB 180 2-Stage Specifications

Frame Size	180									
Ratio	Units	Note	3	4	5	6	7	8	9	10
Nominal Output Torque	[Nm]	*1	421	604	646	646	646	646	478	478
Maximum Acceleration Torque	[Nm]	*2	679	904	1127	1315	1315	1315	931	931
Maximum Torque	[Nm]	*3	750	1064	1327	1498	1498	1498	1144	1144
Emergency Stop Torque	[Nm]	*4	1300	1700	2000	2500	2500	2500	2000	2000
Nominal Input Speed	[rpm]	*5	1500							
Maximum Input Speed	[rpm]	*6	4000							
No Load Running Torque	[Nm]	*7	10.8							
Maximum Radial Load	[N]	*8	15000							
Maximum Axial Load	[N]	*9	14000							
Moment of Inertia ( $\leq \varnothing 28$ )	[kgcm <sup>2</sup> ]	--	--	--	--	--	--	--	--	--
Moment of Inertia ( $\leq \varnothing 38$ )	[kgcm <sup>2</sup> ]	--	93.71	77.72	71.89	68.74	66.43	65.27	64.6	64.28
Moment of Inertia ( $\leq \varnothing 48$ )	[kgcm <sup>2</sup> ]	--	128.6	112.6	106.8	103.6	101.3	100.1	99.46	99.14
Moment of Inertia ( $\leq \varnothing 65$ )	[kgcm <sup>2</sup> ]	--	214.2	198.2	192.4	189.2	186.9	185.7	185.1	184.7
Efficiency	[%]	*10	93							
Torsional Rigidity	[Nm/arcmin]	*11	175							
Maximum Torsional Backlash	[Arc-min]	--	$\leq 6$							
Noise Level	dB [A]	*12	$\leq 85$							
Protection Class	--	*13	IP54 (IP65)							
Ambient Temperature	[°C]	--	0-40							
Permitted Housing Temperature	[°C]	--	90							
Weight	[kg]	*14	49							

## EVB 180 3-Stage Specifications

Frame Size	180									
Ratio	Units	Note	15	16	20	25	28	30	35	40
Nominal Output Torque	[Nm]	*1	442	583	646	683	710	480	710	465
Maximum Acceleration Torque	[Nm]	*2	916	1315	1315	1315	1315	916	1315	1315
Maximum Torque	[Nm]	*3	916	1315	1315	1315	1315	916	1315	1315
Emergency Stop Torque	[Nm]	*4	2000	2500	2500	2500	2500	2000	2500	2500
Nominal Input Speed	[rpm]	*5	2100							
Maximum Input Speed	[rpm]	*6	4000							
No Load Running Torque	[Nm]	*7	4.7							
Maximum Radial Load	[N]	*8	15000							
Maximum Axial Load	[N]	*9	14000							
Moment of Inertia ( $\leq \varnothing 28$ )	[kgcm <sup>2</sup> ]	--	11.49	12.09	11.15	10.98	11.59	10.33	10.83	10.24
Moment of Inertia ( $\leq \varnothing 38$ )	[kgcm <sup>2</sup> ]	--	20.28	20.88	19.94	19.77	20.38	19.11	19.62	19.03
Moment of Inertia ( $\leq \varnothing 48$ )	[kgcm <sup>2</sup> ]	--	25.1	25.7	24.76	24.59	25.20	23.94	24.44	23.85
Moment of Inertia ( $\leq \varnothing 65$ )	[kgcm <sup>2</sup> ]	--	--	--	--	--	--	--	--	--
Efficiency	[%]	*10	88							
Torsional Rigidity	[Nm/arcmin]	*11	175							
Maximum Torsional Backlash	[Arc-min]	--	$\leq 9$							
Noise Level	dB [A]	*12	$\leq 85$							
Protection Class	--	*13	IP54 (IP65)							
Ambient Temperature	[°C]	--	0-40							
Permitted Housing Temperature	[°C]	--	90							
Weight	[kg]	*14	36							

## EVB 180 3-Stage Specifications

Frame Size	180										
Ratio	Units	Note	45	50	60	70	80	90	100		
Nominal Output Torque	[Nm]	*1	480	710	710	710	710	480	480		
Maximum Acceleration Torque	[Nm]	*2	931	1315	1315	1315	1315	931	931		
Maximum Torque	[Nm]	*3	931	1315	1315	1315	1315	931	931		
Emergency Stop Torque	[Nm]	*4	2000	2500	2500	2500	2500	2000	2000		
Nominal Input Speed	[rpm]	*5	2100								
Maximum Input Speed	[rpm]	*6	4000								
No Load Running Torque	[Nm]	*7	4.7								
Maximum Radial Load	[N]	*8	15000								
Maximum Axial Load	[N]	*9	14000								
Moment of Inertia ( $\leq \varnothing 28$ )	[kgcm <sup>2</sup> ]	--	10.76	10.2	10.18	10.16	10.15	10.15	10.14		
Moment of Inertia ( $\leq \varnothing 38$ )	[kgcm <sup>2</sup> ]	--	19.55	18.99	18.96	18.95	18.94	18.93	18.93		
Moment of Inertia ( $\leq \varnothing 48$ )	[kgcm <sup>2</sup> ]	--	24.37	23.81	23.78	23.77	23.76	23.75	23.75		
Moment of Inertia ( $\leq \varnothing 65$ )	[kgcm <sup>2</sup> ]	--	--	--	--	--	--	--	--		
Efficiency	[%]	*10	88								
Torsional Rigidity	[Nm/arcmin]	*11	175								
Maximum Torsional Backlash	[Arc-min]	--	$\leq 9$								
Noise Level	dB [A]	*12	$\leq 85$								
Protection Class	--	*13	IP54 (IP65)								
Ambient Temperature	[°C]	--	0-40								
Permitted Housing Temperature	[°C]	--	90								
Weight	[kg]	*14	36								

\*1) At nominal input speed, service life is 20,000 hours

\*2) The maximum torque when starting or stopping operation. Apply Cycle Factor  $f_0$ , found on page 468, for higher duty cycle applications

\*3) Permitted 10,000 times during service life. Based on 10% of maximum radial load and smooth output shaft

\*4) The maximum torque allowed under a stress situation. Permitted 1,000 times during service life

\*5) The average input speed at nominal input torque. Maintain housing temperature below permitted value

\*6) The maximum intermittent input speed

\*7) Torque at no load applied to the input shaft at nominal input speed

\*8) The maximum radial load that the gearbox can accept

\*9) The maximum axial load that the gearbox can accept

\*10) The efficiency at the nominal output torque rating

\*11) This does not include lost motion

\*12) Contact NIDEC-SHIMPO for the testing conditions and environment

\*13) Various wash-down options are available. Contact NIDEC-SHIMPO for more details

\*14) Weight may vary slightly between models

# EVB SERIES Right-angle Planetary

## EVB 180 2-Stage Dimensions

Input bore size  $\leq \varnothing 38$  mm

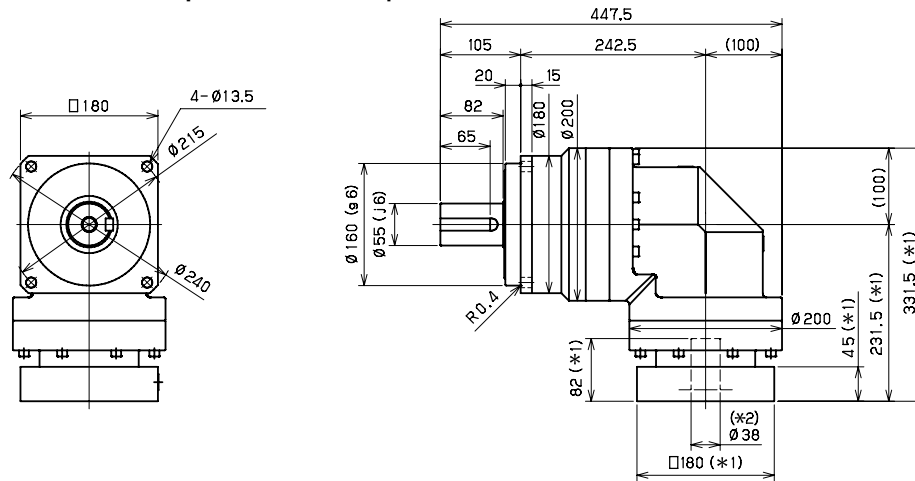

Input bore size  $\leq \varnothing 48$  mm

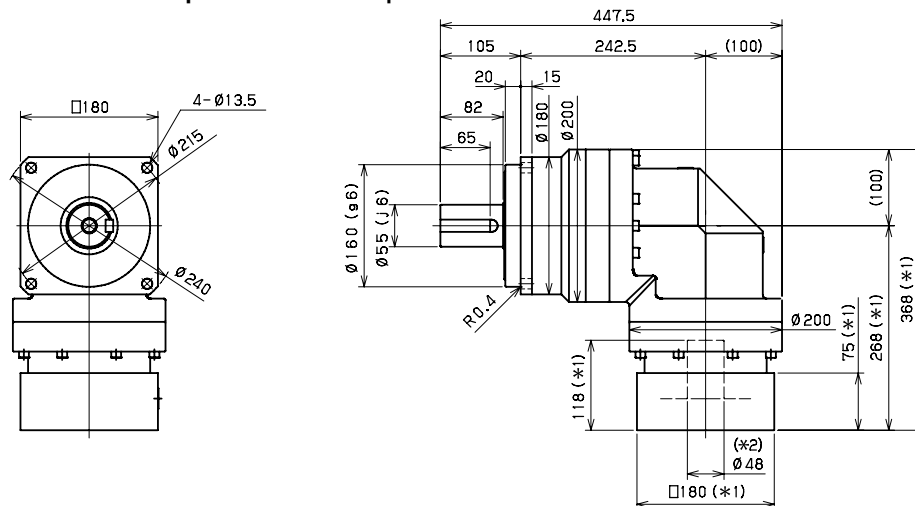

Input bore size  $\leq \varnothing 65$  mm

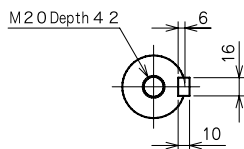
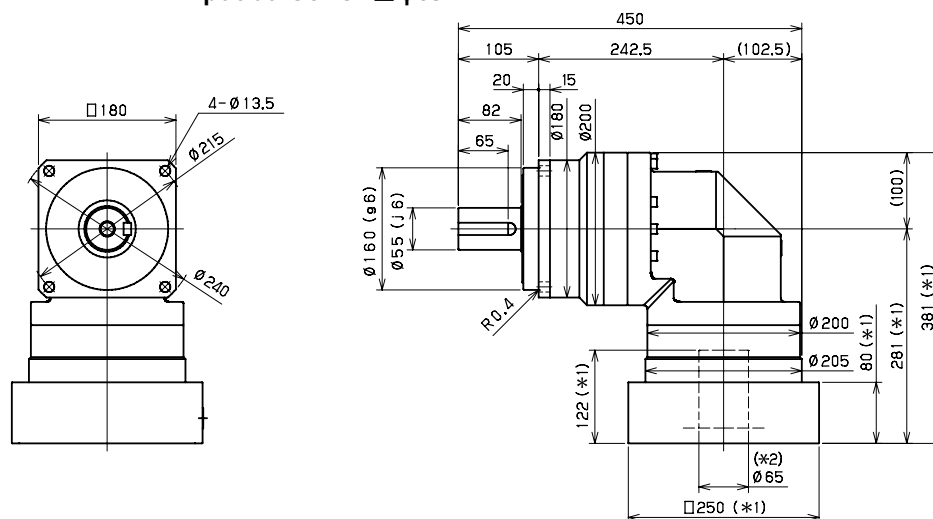

Keyed shaft

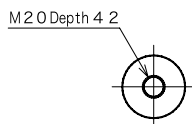

Smooth shaft

\*1) Length will vary depending on motor

\*2) Bushing will be inserted to adapt to motor shaft

## EVB 180 3-Stage Dimensions

Input bore size  $\leq \varnothing 28$  mm

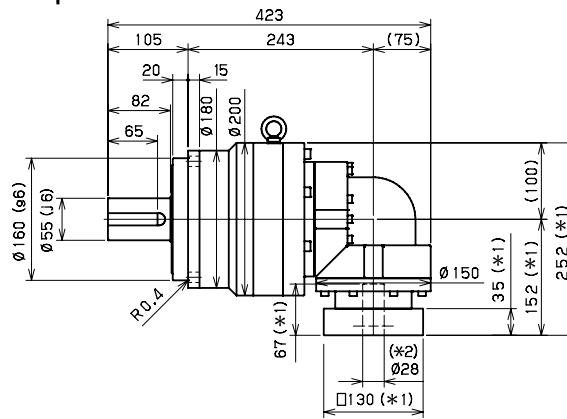
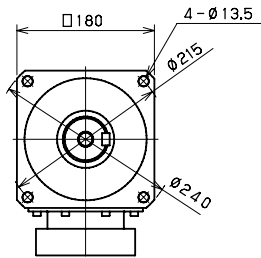

Input bore size  $\leq \varnothing 38$  mm

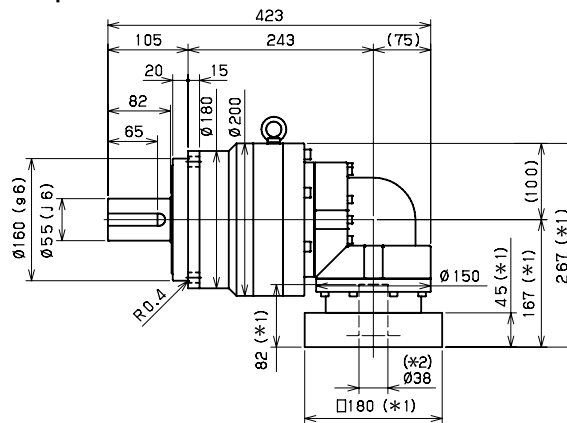
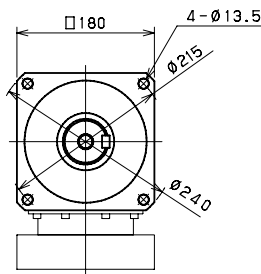

Input bore size  $\leq \varnothing 48$  mm

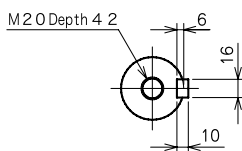
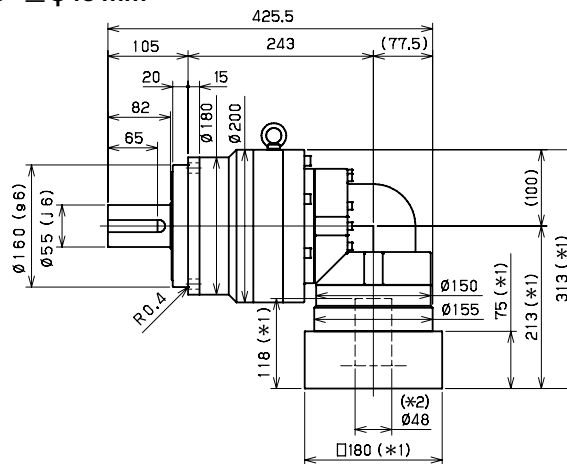
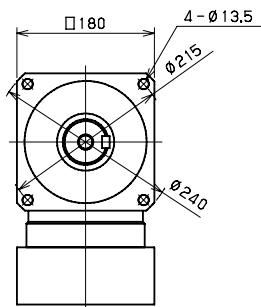

Keyed shaft

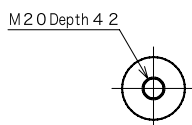

Smooth shaft

\*1) Length will vary depending on motor

\*2) Bushing will be inserted to adapt to motor shaft

EVB

## EVB 220 2-Stage Specifications

Frame Size	220									
Ratio	Units	Note	3	4	5	6	7	8	9	10
Nominal Output Torque	[Nm]	*1	575	765	960	1208	1313	1313	1064	1064
Maximum Acceleration Torque	[Nm]	*2	1160	1555	1945	2112	2112	2063	1812	1529
Maximum Torque	[Nm]	*3	1336	1861	2328	2441	2441	2339	2032	1787
Emergency Stop Torque	[Nm]	*4	2500	3300	4000	4500	4500	4500	3600	3600
Nominal Input Speed	[rpm]	*5	1200							
Maximum Input Speed	[rpm]	*6	3000							
No Load Running Torque	[Nm]	*7	14.5							
Maximum Radial Load	[N]	*8	15000							
Maximum Axial Load	[N]	*9	14000							
Moment of Inertia ( $\leq \varnothing 38$ )	[kgcm <sup>2</sup> ]	--	--	--	--	--	--	--	--	--
Moment of Inertia ( $\leq \varnothing 48$ )	[kgcm <sup>2</sup> ]	--	148.0	122.9	113.3	108.1	104.7	102.7	101.6	101.0
Moment of Inertia ( $\leq \varnothing 65$ )	[kgcm <sup>2</sup> ]	--	223.2	198.1	188.6	183.3	180.0	178.0	176.8	176.2
Efficiency	[%]	*10	93							
Torsional Rigidity	[Nm/arcmin]	*11	400							
Maximum Torsional Backlash	[Arc-min]	--	$\leq 6$							
Noise Level	dB [A]	*12	$\leq 85$							
Protection Class	--	*13	IP54 (IP65)							
Ambient Temperature	[°C]	--	0-40							
Permitted Housing Temperature	[°C]	--	90							
Weight	[kg]	*14	66							

## EVB 220 3-Stage Specifications

Frame Size	220									
Ratio	Units	Note	15	16	20	25	28	30	35	40
Nominal Output Torque	[Nm]	*1	858	1200	1200	1360	1440	948	1440	1440
Maximum Acceleration Torque	[Nm]	*2	1463	2112	2112	2112	2112	1463	2112	2112
Maximum Torque	[Nm]	*3	1463	2112	2112	2112	2112	1463	2112	2112
Emergency Stop Torque	[Nm]	*4	3600	4500	4500	4500	4500	3600	4500	4500
Nominal Input Speed	[rpm]	*5	1500							
Maximum Input Speed	[rpm]	*6	3000							
No Load Running Torque	[Nm]	*7	10.2							
Maximum Radial Load	[N]	*8	15000							
Maximum Axial Load	[N]	*9	14000							
Moment of Inertia ( $\leq \varnothing 38$ )	[kgcm <sup>2</sup> ]	--	36.32	37.24	35.75	35.47	36.39	34.39	35.21	34.25
Moment of Inertia ( $\leq \varnothing 48$ )	[kgcm <sup>2</sup> ]	--	66.14	67.06	65.57	65.28	66.21	64.21	65.03	64.07
Moment of Inertia ( $\leq \varnothing 65$ )	[kgcm <sup>2</sup> ]	--	--	--	--	--	--	--	--	--
Efficiency	[%]	*10	88							
Torsional Rigidity	[Nm/arcmin]	*11	400							
Maximum Torsional Backlash	[Arc-min]	--	$\leq 9$							
Noise Level	dB [A]	*12	$\leq 85$							
Protection Class	--	*13	IP54 (IP65)							
Ambient Temperature	[°C]	--	0-40							
Permitted Housing Temperature	[°C]	--	90							
Weight	[kg]	*14	67							

## EVB 220 3-Stage Specifications

Frame Size	220										
Ratio	Units	Note	45	50	60	70	80	90	100		
Nominal Output Torque	[Nm]	*1	948	1440	1440	1440	1440	948	948		
Maximum Acceleration Torque	[Nm]	*2	1246	2112	2112	2112	1728	1246	1131		
Maximum Torque	[Nm]	*3	1246	2112	2112	2112	1728	1246	1131		
Emergency Stop Torque	[Nm]	*4	3600	4500	4500	4500	4500	3600	3600		
Nominal Input Speed	[rpm]	*5	1500								
Maximum Input Speed	[rpm]	*6	3000								
No Load Running Torque	[Nm]	*7	10.2								
Maximum Radial Load	[N]	*8	15000								
Maximum Axial Load	[N]	*9	14000								
Moment of Inertia ( $\leq \varnothing 38$ )	[kgcm <sup>2</sup> ]	--	35.10	34.18	34.14	34.11	34.1	34.09	34.08		
Moment of Inertia ( $\leq \varnothing 48$ )	[kgcm <sup>2</sup> ]	--	64.92	63.99	63.95	63.93	63.91	63.90	63.90		
Moment of Inertia ( $\leq \varnothing 65$ )	[kgcm <sup>2</sup> ]	--	--	--	--	--	--	--	--		
Efficiency	[%]	*10	88								
Torsional Rigidity	[Nm/arcmin]	*11	400								
Maximum Torsional Backlash	[Arc-min]	--	$\leq 9$								
Noise Level	dB [A]	*12	$\leq 85$								
Protection Class	--	*13	IP54 (IP65)								
Ambient Temperature	[°C]	--	0-40								
Permitted Housing Temperature	[°C]	--	90								
Weight	[kg]	*14	67								

- \*1) At nominal input speed, service life is 20,000 hours
- \*2) The maximum torque when starting or stopping operation. Apply Cycle Factor  $f_0$ , found on page 468, for higher duty cycle applications
- \*3) Permitted 10,000 times during service life. Based on 10% of maximum radial load and smooth output shaft
- \*4) The maximum torque allowed under a stress situation. Permitted 1,000 times during service life
- \*5) The average input speed at nominal input torque. Maintain housing temperature below permitted value
- \*6) The maximum intermittent input speed
- \*7) Torque at no load applied to the input shaft at nominal input speed
- \*8) The maximum radial load that the gearbox can accept
- \*9) The maximum axial load that the gearbox can accept
- \*10) The efficiency at the nominal output torque rating
- \*11) This does not include lost motion
- \*12) Contact NIDEC-SHIMPO for the testing conditions and environment
- \*13) Various wash-down options are available. Contact NIDEC-SHIMPO for more details
- \*14) Weight may vary slightly between models

# EVB SERIES Right-angle Planetary

## EVB 220 2-Stage Dimensions

Input bore size  $\leq \varnothing 48$  mm

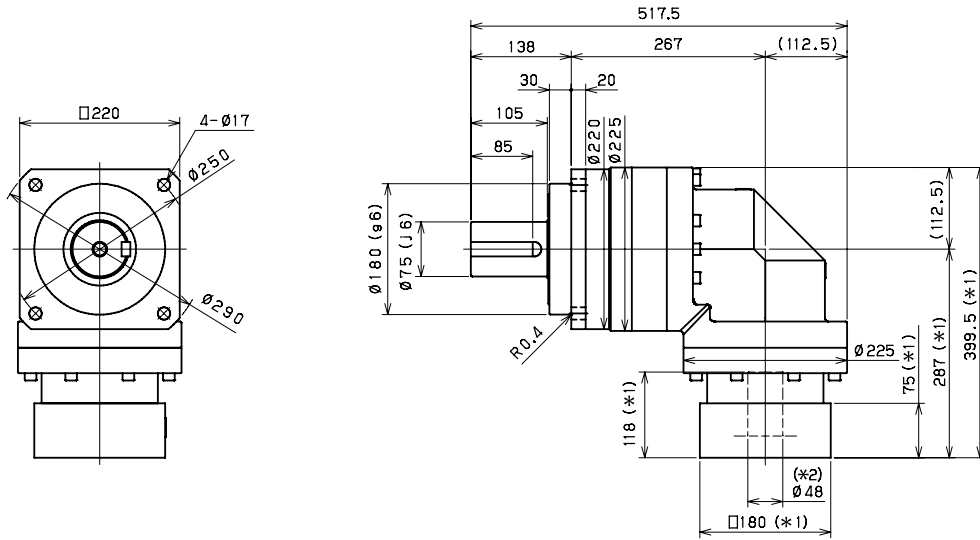

Input bore size  $\leq \varnothing 65$  mm

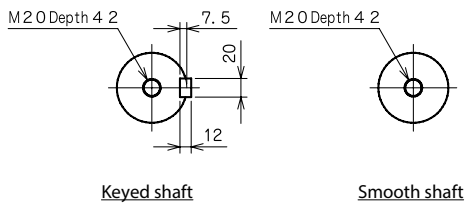
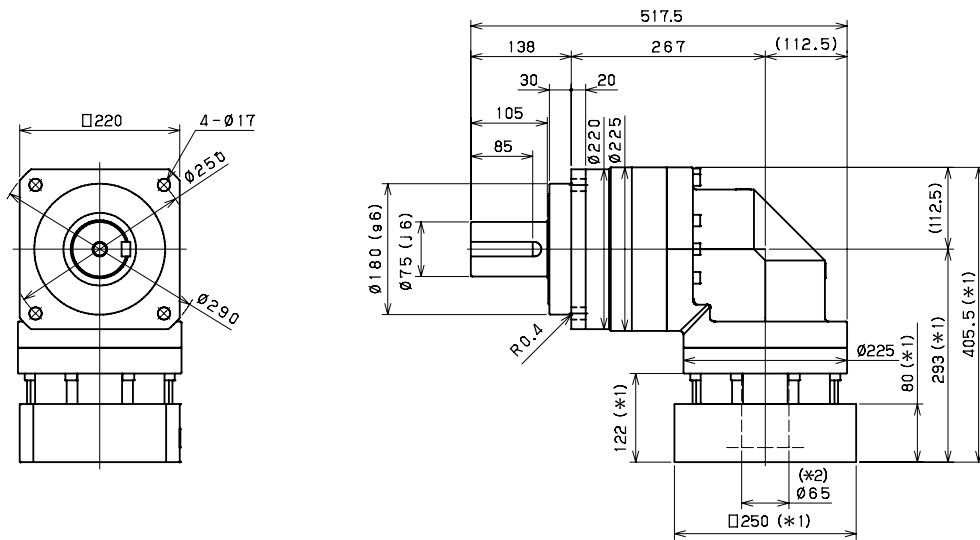

- \*1) Length will vary depending on motor
- \*2) Bushing will be inserted to adapt to motor shaft

